

Алматы (727)345-47-04
Ангарск (3955)60-70-56
Архангельск (8182)63-90-72
Астрахань (8512)99-46-04
Барнаул (3852)73-04-60
Белгород (4722)40-23-64
Благовещенск (4162)22-76-07
Брянск (4832)59-03-52
Владивосток (423)249-28-31
Владикавказ (8672)28-90-48
Владимир (4922)49-43-18
Волгоград (844)278-03-48
Вологда (8172)26-41-59
Воронеж (473)204-51-73
Екатеринбург (343)384-55-89

Иваново (4932)77-34-06
Ижевск (3412)26-03-58
Иркутск (395)279-98-46
Казань (843)206-01-48
Калининград (4012)72-03-81
Калуга (4842)92-23-67
Кемерово (3842)65-04-62
Киров (8332)68-02-04
Коломна (4966)23-41-49
Кострома (4942)77-07-48
Краснодар (861)203-40-90
Красноярск (391)204-63-61
Курск (4712)77-13-04
Курган (3522)50-90-47
Липецк (4742)52-20-81

Магнитогорск (3519)55-03-13
Москва (495)268-04-70
Мурманск (8152)59-64-93
Набережные Челны (8552)20-53-41
Нижний Новгород (831)429-08-12
Новокузнецк (3843)20-46-81
Ноябрьск (3496)41-32-12
Новосибирск (383)227-86-73
Омск (3812)21-46-40
Орел (4862)44-53-42
Оренбург (3532)37-68-04
Пенза (8412)22-31-16
Петрозаводск (8142)55-98-37
Псков (8112)59-10-37
Пермь (342)205-81-47

Ростов-на-Дону (863)308-18-15
Рязань (4912)46-61-64
Самара (846)206-03-16
Санкт-Петербург (812)309-46-40
Саранск (8342)22-96-24
Саратов (845)249-38-78
Севастополь (8692)22-31-93
Симферополь (3652)67-13-56
Смоленск (4812)29-41-54
Сочи (862)225-72-31
Ставрополь (8652)20-65-13
Сургут (3462)77-98-35
Сыктывкар (8212)25-95-17
Тамбов (4752)50-40-97
Тверь (4822)63-31-35

Тольятти (8482)63-91-07
Томск (3822)98-41-53
Тула (4872)33-79-87
Тюмень (3452)66-21-18
Улан-Удэ (3012)59-97-51
Ульяновск (8422)24-23-59
Уфа (347)229-48-12
Хабаровск (4212)92-98-04
Чебоксары (8352)28-53-07
Челябинск (351)202-03-61
Череповец (8202)49-02-64
Чита (3022)38-34-83
Якутск (4112)23-90-97
Ярославль (4852)69-52-93

Россия +7(495)268-04-70

Казахстан +7(727)345-47-04

Беларусь +(375)257-127-884

Узбекистан +998(71)205-18-59

Киргизия +996(312)96-26-47

<https://mpfiltri.nt-rt.ru> || mqt@nt-rt.ru

CONTAMINATION
CONTROL
SOLUTIONS

CATALOGUE



PASSION TO PERFORM

CONTAMINATION CONTROL SOLUTIONS



A WORLDWIDE LEADER IN THE FIELD
OF HYDRAULIC FILTRATION EQUIPMENT.

Our company started life in 1964, when Bruno Pasotto decided to attempt to cater for the requests of a market still to be fully explored, with the study, design, development, production and marketing of a vast range of filters for hydraulic equipment, capable of satisfying the needs of manufacturers in all sectors. The quality of our products, our extreme competitiveness compared with major international producers and our constant activities of research, design and development has made us a worldwide leader in the field of hydraulic circuit filtering. Present for over 50 years in the market, we have played a truly decisive role in defining our sector, and by now we are a group capable of controlling our entire chain of production, monitoring all manufacturing processes to guarantee superior quality standards and to provide concrete solutions for the rapidly evolving needs of customers and the market.

1 page INTRODUCTION

4	COMPANY PROFILE
8	PRODUCT RANGE
11	CONTAMINATION MANAGEMENT

18 page CONTAMINATION MONITORING PRODUCTS

21	LPA3	Portable Light Extinction Particle Analyser
27	LPA2 Aviation Edition	Portable Twin-laser Particle Analyser
33	CML3	Compact Portable Contamination Monitor
39	CML4	Compact Portable Contamination Monitor
45	ICM 4.0	Wifi-enabled In-line Contamination Monitor
51	ICM 2.0	In-line Contamination Monitor
57	ICM K 2.0 AZ2	ATEX Inline Contamination Monitor
63	ICS	In-line Contamination Sensor
69	ICU	In-line Contamination Monitoring Unit
75	ACMU	Auxiliary Contamination Monitoring Unit
83	BS110 & BS500	Bottle Samplers
92	HOW SAMPLING	
95	PATCH IMAGING KIT	Patch Sampling and Digital Imaging Kit
99	FLUID COMPATIBILITY CHARTS	

100 page MOBILE FILTRATION UNITS

103	UFM 015	Mobile filtration unit 15 l/min flow rate
113	UFM 041	Mobile filtration unit 34 l/min flow rate
119	UFM 051	Mobile filtration unit 50 l/min flow rate
125	UFM 091	Mobile filtration unit 90 l/min flow rate
131	UFM 181	Mobile filtration unit 180 l/min flow rate
137	UFM 919	Mobile filtration unit 90 l/min and 180 l/min flow rate
143	FTU	Fluid transfer unit 15 l/min flow rate, with ICM 2.0 / 4.0 (In-line Contamination Monitor)

Our work is based on a skillful interaction between advanced technology and fine workmanship, **customizing products according to specific market requests**, focusing strongly on innovation and quality, and following every step in the manufacturing of both standard and special products, fully respecting customer expectations.

MARKET
LEADER



Our customer-oriented philosophy, which enables us to satisfy all customer requests **rapidly** and **with personalized products**, makes us a **dynamic and flexible enterprise**.

The possibility of constantly controlling and monitoring the entire production process is essential to allow us to guarantee the quality of our products.

WORLDWIDE PRESENCE

Our foreign Branches enable us to offer a diversified range of products that allow us to successfully face the aggressive challenge of international competition, and also to maintain a stable presence at a local level.

The Group boasts **9** business branches



TECHNOLOGY

Our constant **quest for excellence in quality and technological innovation** allows us to offer only the best solutions and services for applications in many fields, including general industry, test rigs, lubrication, heavy engineering, renewable energies, naval engineering, offshore engineering, aviation systems, emerging technologies and mobile plant (i.e. tractors, excavators, concrete pumps, platforms).



AND PRODUCTION

Our high level of technological expertise means **we can rely entirely on our own resources, without resorting to external providers.** This in turn enables us to satisfy a growing number of customer requests, also exploiting our constantly updated range of machines and equipment, featuring **fully-automated workstations** capable of **24-hour production.**





SUCTION FILTERS

- Mounting:
- Tank immersed
 - In-Line
 - In tank with shut off valve
 - In tank with flooded suction



RETURN FILTERS

- Mounting:
- In-Line
 - Tank top
 - In single and duplex designs



RETURN / SUCTION FILTERS

- Mounting:
- In-Line
 - Tank top



SPIN-ON FILTERS

- Mounting:
- In-Line
 - Tank top



LOW & MEDIUM PRESSURE FILTERS

- Mounting:
- In-Line
 - Parallel manifold version
 - In single and duplex designs



HIGH PRESSURE FILTERS

- Mounting:
- In-Line
 - Manifold
 - In single and duplex designs

PRODUCT RANGE

MP Filtri can offer a vast and articulated range of products for the global market, suitable for all industrial sectors using hydraulic equipment.

This includes filters (suction, return, return/suction, spin-on, pressure, stainless steel pressure, ATEX filters) and structural components (motor/pump bell-housings, transmission couplings, damping rings, foot brackets, aluminium tanks, cleaning covers).

We can provide all the skills and solutions required by the modern hydraulics industry to monitor contamination levels and other fluid conditions.

Mobile filtration units and a full range of accessories allow us to supply everything necessary for a complete service in the hydraulic circuits.



STAINLESS STEEL HIGH PRESSURE FILTERS

- Mounting:
- In-Line
 - Manifold
 - In single and duplex designs

FILTERS FOR POTENTIALLY EXPLOSIVE ATMOSPHERE

- Mounting:
- In-Line

CONTAMINATION CONTROL SOLUTIONS

- Off-line, in-line particle analyser
- Off-line bottle sampling products
- Fully calibrated using relevant ISO standards
- A wide range of variants to support fluid types and communication protocols
- Mobile Filtration Units with flow rates from 15 l/min up to 200 l/min

POWER TRANSMISSION PRODUCTS

- Aluminium bell-housings for motors from 0.12 kW to 400 kW
- Couplings in Aluminium Cast Iron - Steel
- Damping rings
- Foot bracket
- Aluminium tanks
- Cleaning covers

TANK ACCESSORIES

- Oil filler and air breather plugs
- Optical and electrical level gauges
- Pressure gauge valve selectors
- Pipe fixing brackets
- Pressure gauges

Contamination management

INDEX

	Page
① HYDRAULIC FLUIDS	12
② FLUIDS CONTAMINATION	12
③ FLUIDS COMPATIBILITY CHART	12
④ EFFECTS OF CONTAMINATION ON HYDRAULIC COMPONENTS	13
⑤ MEASURING THE SOLID CONTAMINATION LEVEL	13
⑥ FILTRATION TECHNOLOGIES	16
⑦ APPLICABLE STANDARDS FOR FILTER DEVELOPMENT	17

1 HYDRAULIC FLUIDS

The fluid is the vector that transmits power, energy within an oleodynamic circuit. In addition to transmitting energy through the circuit, it also performs additional functions such as lubrication, protection and cooling of the surfaces.

The classification of fluids used in hydraulic systems is coded in many regulatory references, different Standards.

The most important classification system for hydraulic fluids is the one defined by International Organization for Standardization (ISO), which established a classification system within their standard: "ISO 6743-4 Lubricants, Industrial Oils and Related Products". In particular, the parts of interest for hydraulic fluids are:

- Lubricants, industrial oils and related products (class L)
- Classifications - Part 4L - Family H (Hydraulic systems)

The ISO 6743-4 classification system can be generally applied to the three primary classes of hydraulic fluids:

- Mineral Oils (i.e.: petroleum) Hydraulic Fluids (i.e.: HH: Mineral lubricants without corrosion inhibitors; HL: HH-type lubricants with oxidation reduction and anticorrosive additives; HM: HL-type lubricants with anti-wear additives; HV: HM-type lubricants with a higher viscosity grade and temperature properties; and others).
- Biodegradable Hydraulic Fluids (HExx), also defined as "Environmentally acceptable hydraulic fluids".
- Fire Resistant Hydraulic Fluids (HFxx), which could be further split into: Fire-resistant aqueous fluids (HFAx, HFB; HFC) ; Fire-resistant synthetic anhydrous fluids (HFDx).

The choice of fluid for an hydraulic system must take into account several parameters.

These parameters can adversely affect the performance of an hydraulic system, causing delay in the controls, pump cavitation, excessive absorption, excessive temperature rise, efficiency reduction, increased drainage, wear, jam/block or air intake in the plant.

The main properties that characterize hydraulic fluids and affect their choice are:

- **DYNAMIC VISCOSITY**
It identifies the fluid's resistance to sliding due to the impact of the particles forming it.
- **KINEMATIC VISCOSITY**
It is a widespread formal dimension in the hydraulic field.
It is calculated with the ratio between the dynamic viscosity and the fluid density.
Kinematic viscosity varies with temperature and pressure variations.
- **VISCOSITY INDEX**
This value expresses the ability of a fluid to maintain viscosity when the temperature changes.
A high viscosity index indicates the fluid's ability to limit viscosity variations by varying the temperature.
- **FILTERABILITY INDEX**
It is the value that indicates the ability of a fluid to cross the filter materials.
A low filterability index could cause premature clogging of the filter material.
- **WORKING TEMPERATURE**
Working temperature affects the fundamental characteristics of the fluid.
As already seen, some fluid characteristics, such as cinematic viscosity, vary with the temperature variation.

When choosing a hydraulic oil, must therefore be taken into account of the environmental conditions in which the machine will operate.

- **COMPRESSIBILITY MODULE**
Every fluid subjected to a pressure contracts, increasing its density.
The compressibility module identifies the increase in pressure required to cause a corresponding increase in density.
- **HYDROLYTIC STABILITY**
It is the characteristic that prevents galvanic pairs that can cause wear in the plant/system.
- **ANTIOXIDANT STABILITY AND WEAR PROTECTION**
These features translate into the capacity of a hydraulic oil to avoid corrosion of metal elements inside the system.
- **HEAT TRANSFER CAPACITY**
It is the characteristic that indicates the capacity of hydraulic oil to exchange heat with the surfaces and then cool them.

2 FLUID CONTAMINATION

Whatever the nature and properties of fluids, they are inevitably subject to contamination. Fluid contamination can have two origins:

- **INITIAL CONTAMINATION**
Caused by the introduction of contaminated fluid into the circuit, or by incorrect storage, transport or transfer operations.
- **PROGRESSIVE CONTAMINATION**
Caused by factors related to the operation of the system, such as metal surface wear, sealing wear, oxidation or degradation of the fluid, the introduction of contaminants during maintenance, corrosion due to chemical or electrochemical action between fluid and components, cavitation.
The contamination of hydraulic systems can be of different nature:
- **SOLID CONTAMINATION**
For example rust, slag, metal particles, fibers, rubber particles, paint particles or additives
- **LIQUID CONTAMINATION**
For example, the presence of water due to condensation or external infiltration or acids
- **GASEOUS CONTAMINATION**
For example, the presence of air due to inadequate oil level in the tank, drainage in suction ducts, incorrect sizing of tubes or tanks.

3 FLUID COMPATIBILITY CHARTS

4 EFFECTS OF CONTAMINATION ON HYDRAULIC COMPONENTS

Solid contamination is recognized as the main cause of malfunction, failure and early degradation in hydraulic systems. It is impossible to delete it completely, but it can be effectively controlled by appropriate devices.

CONTAMINATION IN PRESENCE OF LARGE TOLERANCES



CONTAMINATION IN PRESENCE OF NARROW TOLERANCES



Solid contamination mainly causes surface damage and component wear.

- ABRASION OF SURFACES
Cause of leakage through mechanical seals, reduction of system performance, failures.
- SURFACE EROSION
Cause of leakage through mechanical seals, reduction of system performance, variation in adjustment of control components, failures.
- ADHESION OF MOVING PARTS
Cause of failure due to lack of lubrication.
- DAMAGES DUE TO FATIGUE
Cause of breakdowns and components breakdown.

ABRASION



EROSION



ADHESION

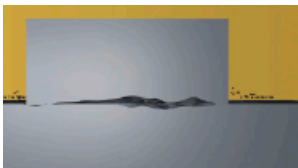

FATIGUE



Liquid contamination mainly results in decay of lubrication performance and protection of fluid surfaces.

DISSOLVED WATER

- INCREASING FLUID ACIDITY
Cause of surface corrosion and premature fluid oxidation
- GALVANIC COUPLE AT HIGH TEMPERATURES
Cause of corrosion

FREE WATER - ADDITIONAL EFFECTS

- DECAY OF LUBRICANT PERFORMANCE
Cause of rust and sludge formation, metal corrosion and increased solid contamination
- BATTERY COLONY CREATION
Cause of worsening in the filterability feature

- ICE CREATION AT LOW TEMPERATURES
Cause damage to the surface
- ADDITIVE DEPLETION
Free water retains polar additives

Gaseous contamination mainly results in decay of system performance.

- CUSHION SUSPENSION
Cause of increased noise and cavitation.
- FLUID OXIDATION
Cause of corrosion acceleration of metal parts.
- MODIFICATION OF FLUID PROPERTIES (COMPRESSIBILITY MODULE, DENSITY, VISCOSITY)
Cause of system's reduction of efficiency and of control. It is easy to understand how a system without proper contamination management is subject to higher costs than a system that is provided.
- MAINTENANCE
Increase maintenance activities, spare parts, machine stop costs.
- ENERGY AND EFFICIENCY
Efficiency and performance reduction due to friction, drainage, cavitation.

5 MEASURING THE SOLID CONTAMINATION LEVEL

The level of contamination of a system identifies the amount of contaminant contained in a fluid. This parameter refers to a unit volume of fluid. The level of contamination may be different at different points in the system. From the information in the previous paragraphs it is also apparent that the level of contamination is heavily influenced by the working conditions of the system, by its working years and by the environmental conditions.

What is the size of the contaminating particles that we must handle in our hydraulic circuit?

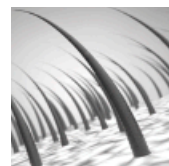

HUMAN HAIR (75 µm)

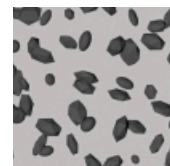

MINIMUM DIMENSION VISIBLE WITH HUMAN EYES (40 µm)

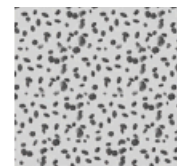

TYPICAL CONTAMINANT DIMENSION IN A HYDRAULIC CIRCUIT (4 - 14 µm)

Contamination level analysis is significant only if performed with a uniform and repeatable method, conducted with standard test methods and suitably calibrated equipment. To this end, ISO has issued a set of standards that allow tests to be conducted and express the measured values in the following ways.

- GRAVIMETRIC LEVEL - ISO 4405

The level of contamination is defined by checking the weight of particles collected by a laboratory membrane. The membrane must be cleaned, dried and desiccated, with fluid and conditions defined by the Standard. The volume of fluid is filtered through the membrane by using a suitable suction system. The weight of the contaminant is determined by checking the weight of the membrane before and after the fluid filtration.



CLEAN MEMBRANE

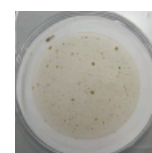

CONTAMINATED MEMBRANE

CONTAMINATION MANAGEMENT

- CUMULATIVE DISTRIBUTION OF THE PARTICLES SIZE - ISO 4406

The level of contamination is defined by counting the number of particles of certain dimensions per unit of volume of fluid. Measurement is performed by Contamination Monitoring Products (CMP).

Following the count, the contamination classes are determined, corresponding to the number of particles detected in the unit of fluid.

The most common classification methods follow ISO 4406 and SAE AS 4059 (Aerospace Sector) regulations.

NAS 1638 is still used although obsolete.

Classification example according to ISO 4406

The International Standards Organization standard ISO 4406 is the preferred method of quoting the number of solid contaminant particles in a sample. The level of contamination is defined by counting the number of particles of certain dimensions per unit of volume of fluid. The measurement is performed by Contamination Monitoring Products (CMP).

The numbers represent a code which identifies the number of particles of certain sizes in 1ml of fluid. Each code number has a particular size range. The first scale number represents the number of particles equal to or larger than 4 $\mu\text{m}_{(c)}$ per millilitre of fluid; The second scale number represents the number of particles equal to or larger than 6 $\mu\text{m}_{(c)}$ per millilitre of fluid; The third scale number represents the number of particles equal to or larger than 14 $\mu\text{m}_{(c)}$ per millilitre of fluid.

ISO 4406 - Allocation of Scale Numbers

Class	Number of particles per ml	
	Over	Up to
28	1 300 000	2 500 000
27	640 000	1 300 000
26	320 000	640 000
25	160 000	320 000
24	80 000	160 000
23	40 000	80 000
22	20 000	40 000
21	10 000	20 000
20	5 000	10 000
19	2 500	5 000
18	1 300	2 500
17	640	1 300
16	320	640
15	160	320
14	80	160
13	40	80
12	20	40
11	10	20
10	5	10
9	2.5	5
8	1.3	2.5
7	0.64	1.3
6	0.32	0.64
5	0.16	0.32
4	0.08	0.16
3	0.04	0.08
2	0.02	0.04
1	0.01	0.02
0	0	0.01

- > 4 $\mu\text{m}_{(c)}$ = 350 particles
 - > 6 $\mu\text{m}_{(c)}$ = 100 particles
 - > 14 $\mu\text{m}_{(c)}$ = 25 particles
- 16 / 14 / 12

ISO 4406 Cleanliness Code System

Microscope counting examines the particles differently to Contamination Monitoring Products (CMP) and the code is given with two scale numbers only. These are at 5 μm and 15 μm equivalent to the 6 $\mu\text{m}_{(c)}$ and 14 $\mu\text{m}_{(c)}$ of Contamination Monitoring Products (CMP).

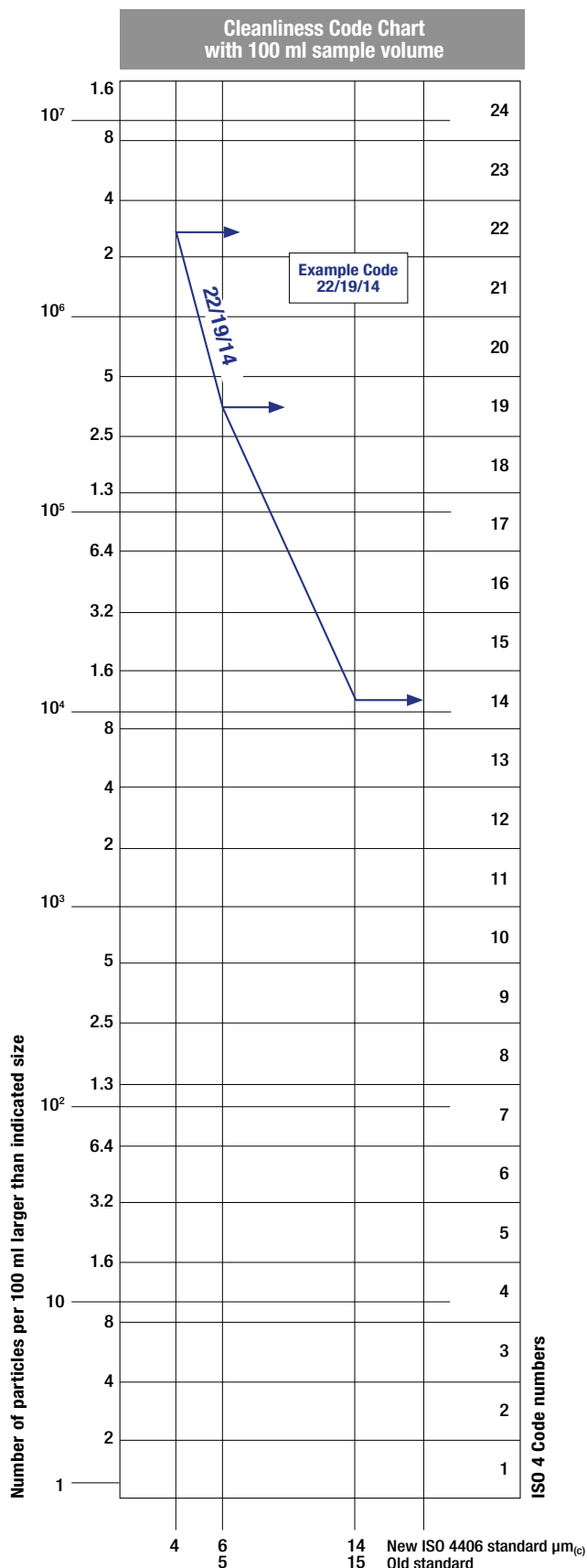

- CUMULATIVE DISTRIBUTION OF THE PARTICLES SIZE
SAE AS4059-1 and SAE AS4059-2

Classification example according to SAE AS4059 - Rev. G

The code, prepared for the aerospace industry, is based on the size, quantity, and particle spacing in a 100 ml fluid sample. The contamination classes are defined by numeric codes, the size of the contaminant is identified by letters (A-F).

This SAE Aerospace Standard (AS) defines cleanliness levels for particulate contamination of hydraulic fluids and includes methods of reporting data relating to the contamination levels. Tables 1 and 2 below provide differential and cumulative particle counts respectively for counts obtained by an automatic particle counter, e.g. LPA3.

Table 1 - Class for differential measurement

Class	Dimension of contaminant Maximum Contamination Limits per 100 ml (3)				
	5-15 µm	15-25 µm	25-50 µm	50-100 µm	>100 µm (1)
	6-14 µm(c) (2)	14-21 µm(c)	21-38 µm(c)	38-70 µm(c)	>70 µm(c)
00	125	22	4	1	0
0	250	44	8	2	0
1	500	89	16	3	1
2	1 000	178	32	6	1
3	2 000	356	63	11	2
4	4 000	712	126	22	4
5	8 000	1 425	253	45	8
6	16 000	2 850	506	90	16
7	32 000	5 700	1 012	180	32
8	64 000	11 400	2 025	360	64
9	128 000	22 800	4 050	720	128
10	256 000	45 600	8 100	1 440	256
11	512 000	91 200	16 200	2 880	512
12	1 024 000	182 400	32 400	5 760	1 024

6 - 14 µm(c) = 15 000 particles
14 - 21 µm(c) = 2 200 particles
21 - 38 µm(c) = 200 particles
38 - 70 µm(c) = 35 particles
> 70 µm(c) = 3 particles
SAE AS4059 REV G - Class 6

(1) Size range, optical microscope, based on longest dimension as measured per AS598 or ISO 4407. (2) Size range CMP calibrated per ISO 11171 or an optical or electron microscope with image analysis software, based on projected area equivalent diameter. (3) Contamination classes and particle count limits are identical to NAS 1638.

Table 2 - Class for cumulative measurement

Class	Dimension of contaminant Maximum Contamination Limits per 100 ml					
	>1 µm	>5 µm	>15 µm	>25 µm	>50 µm	>100 µm (1)
	>4 µm(c) (2)	>6 µm(c)	>14 µm(c)	>21 µm(c)	>38 µm(c)	>70 µm(c)
000	195	76	14	3	1	0
00	390	152	27	5	1	0
0	780	304	54	10	2	0
1	1 560	609	109	20	4	1
2	3 120	1 217	217	39	7	1
3	6 250	2 432	432	76	13	2
4	12 500	4 864	864	152	26	4
5	25 000	9 731	1 731	306	53	8
6	50 000	19 462	3 462	612	106	16
7	100 000	38 924	6 924	1 224	212	32
8	200 000	77 849	13 849	2 449	424	64
9	400 000	155 698	27 698	4 898	848	128
10	800 000	311 396	55 396	9 796	1 696	256
11	1 600 000	622 792	110 792	19 592	3 392	512
12	3 200 000	1 245 584	221 584	39 184	6 784	1 024

> 4 µm(c) = 45 000 particles
> 6 µm(c) = 15 000 particles
> 14 µm(c) = 1 500 particles
> 21 µm(c) = 250 particles
> 38 µm(c) = 15 particles
> 70 µm(c) = 3 particle
SAE AS4059 REV G cpc* Class 6 6/6/5/5/4/2

* cumulative particle count

(1) Size range, optical microscope, based on longest dimension as measured per AS598 or ISO 4407. (2) Size range, CMP calibrated per ISO 11171 or an optical or electron microscope with image analysis software, based on projected area equivalent diameter. (3) Contamination classes and particle count limits are identical to NAS 1638.

- CLASSES OF CONTAMINATION ACCORDING TO NAS 1638 (January 1964)

The NAS system was originally developed in 1964 to define contamination classes for the contamination contained within aircraft components.

The application of this standard was extended to industrial hydraulic systems simply because nothing else existed at the time.

The coding system defines the maximum numbers permitted of 100 ml volume at various size intervals (differential counts) rather than using cumulative counts as in ISO 4406. Although there is no guidance given in the standard on how to quote the levels, most industrial users quote a single code which is the highest recorded in all sizes and this convention is used on MP Filtri Contamination Monitoring Products (CMP).

The contamination classes are defined by a number (from 00 to 12) which indicates the maximum number of particles per 100 ml, counted on a differential basis, in a given size bracket.

Size Range Classes (in microns)

Class	Maximum Contamination Limits per 100 ml				
	5-15	15-25	25-50	50-100	>100
	5-15 µm	15-25 µm	25-50 µm	50-100 µm	>100 µm
00	125	22	4	1	0
0	250	44	8	2	0
1	500	89	16	3	1
2	1 000	178	32	6	1
3	2 000	356	63	11	2
4	4 000	712	126	22	4
5	8 000	1 425	253	45	8
6	16 000	2 850	506	90	16
7	32 000	5 700	1 012	180	32
8	64 000	11 400	2 025	360	64
9	128 000	22 800	4 050	720	128
10	256 000	45 600	8 100	1 440	256
11	512 000	91 200	16 200	2 880	512
12	1 024 000	182 400	32 400	5 760	1 024

5-15 µm = 42 000 particles
15-25 µm = 2 200 particles
25-50 µm = 150 particles
50-100 µm = 18 particles
> 100 µm = 3 particles
Class NAS 8

- CUMULATIVE DISTRIBUTION OF THE PARTICLES SIZE - ISO 4407

The level of contamination is defined by counting the number of particles collected by a laboratory membrane per unit of fluid volume. The measurement is done by a microscope. The membrane must be cleaned, dried and desiccated, with fluid and conditions defined by the Standard. The fluid volume is filtered through the membrane, using a suitable suction system.

The level of contamination is identified by dividing the membrane into a predefined number of areas and by counting the contaminant particles using a suitable laboratory microscope.

MICROSCOPE CONTROL AND MEASUREMENT



Example figure 1 and 2

COMPARISON PHOTOGRAPH'S
1 graduation = 10µm



Fig. 1

Fig. 2

Scan or click me!

CONTAMINATION MANAGEMENT

- CLEANLINESS CODE COMPARISON

Although ISO 4406 standard is being used extensively within the hydraulics industry other standards are occasionally required and a comparison may be requested. The table below gives a very general comparison but often no direct comparison is possible due to the different classes and sizes involved.

ISO 4406	SAE AS4059 Table 2	SAE AS4059 Table 1	NAS 1638
> 4 $\mu\text{m}_{(c)}$ 6 $\mu\text{m}_{(c)}$ 14 $\mu\text{m}_{(c)}$	> 4 $\mu\text{m}_{(c)}$ 6 $\mu\text{m}_{(c)}$ 14 $\mu\text{m}_{(c)}$	4-6 6-14 14-21 21-38 38-70 >70	5-15 15-25 25-50 50-100 >100
23 / 21 / 18	13A / 12B / 12C	12	12
22 / 20 / 17	12A / 11B / 11C	11	11
21 / 19 / 16	11A / 10B / 10C	10	10
20 / 18 / 15	10A / 9B / 9B	9	9
19 / 17 / 14	9A / 8B / 8C	8	8
18 / 16 / 13	8A / 7B / 7C	7	7
17 / 15 / 12	7A / 6B / 6C	6	6
16 / 14 / 11	6A / 5B / 5C	5	5
15 / 13 / 10	5A / 4B / 4C	4	4
14 / 12 / 09	4A / 3B / 3C	3	3

6 FILTRATION TECHNOLOGIES

Various mechanisms such as mechanical stoppage, magnetism, gravimetric deposit, or centrifugal separation can be used to reduce the level of contamination.

The mechanical stoppage method is most effective and can take place in two ways:

- SURFACE FILTRATION

It is by direct interception. The filter prevents particles larger than the pores from continuing in the plant / system. Surface filters are generally manufactured with metal canvases or meshes.

- DEPTH FILTERING

Filters are constructed by fiber interlacing. Such wraps form pathways of different shapes and sizes in which the particles remain trapped when they find smaller apertures than their diameter.

Depth filters are generally produced with papers impregnated with phenolic resins, metal fibers or inorganic fibers.

In inorganic fiber filtration, commonly called microfibre, the filtering layers are often overlapped in order to increase the ability to retain the contaminant.

WIRE MESH FILTRATION

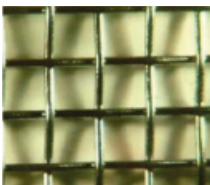

PAPER FILTRATION



MICROFIBER FILTRATION

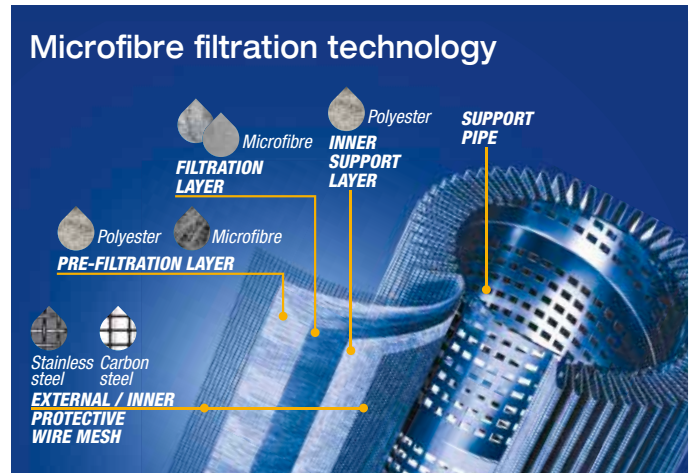
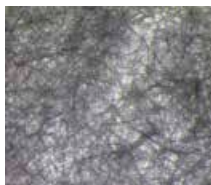

The filtration efficiency of metallic mesh filtrations is defined as the maximum particle size that can pass through the meshes of the filtering grid.

The efficiency of microfibre and paper filtration ($\beta_{X(c)}$) is defined through a lab test called Multipass Test. The efficiency value ($\beta_{X(c)}$) is defined as the ratio between the number of particles of certain dimensions detected upstream and downstream of the filter.

$$\frac{\text{Upstream particles number} > X \mu\text{m}_{(c)}}{\text{Downstream particles number} > X \mu\text{m}_{(c)}} = \beta_{X(c)}$$



Value ($\beta_{X(c)}$)	2	10	75	100	200	1000
Efficiency	50%	90%	98.7%	99%	99.5%	99.9%

Test conditions, such as type of fluid to be used (MIL-H-5606), type of contaminant to be used (ISO MTD), fluid viscosity, test temperature, are determined by ISO 16889.

In addition to the filtration efficiency value during the Multipass test, other important features, such as filtration stability (β stability) and dirt holding capacity (DHC), are also tested.

Poor filtration stability is the cause of the filtering quality worsening as the filter life rises. Low dirt holding capacity causes a reduction in the life of the filter.

Filtration ISO Standard Comparison

$\beta_{X(c)} > 1000$ ISO 16889	$\beta_X > 200$ ISO 4572	MP Filtri Filter media code
5 $\mu\text{m}_{(c)}$	3 μm	A (00) 03
7 $\mu\text{m}_{(c)}$	6 μm	A (00) 06
10 $\mu\text{m}_{(c)}$	10 μm	A (00) 10
16 $\mu\text{m}_{(c)}$	18 μm	A (00) 16
21 $\mu\text{m}_{(c)}$	25 μm	A (00) 25

7 APPLICABLE STANDARDS FOR FILTER DEVELOPMENT

In order to obtain unique criteria for development and verification of the filters performance, specific regulations for the filters and filter elements testing have been issued by ISO. These norms describe the target, the methodology, the conditions and the presentation methods for the test results.

ISO 2941

Hydraulic fluid power -- Filter elements -- Verification of collapse/burst pressure rating

This Standard describes the method for testing the collapse / burst resistance of the filter elements.

The test is performed by crossing the contaminated fluid filter element at a predefined flow rate. The progressive clogging of the filter element, determined by contamination, causes an increase in differential pressure.

ISO 2942

Hydraulic fluid power -- Filter elements -- Verification of fabrication integrity and determination of the first bubble point

This Standard describes the method to verify the integrity of the assembled filter elements.

It can be used to verify the quality of the production process or the quality of the materials by verifying the pressure value of the first bubble point.

ISO 2943

Hydraulic fluid power -- Filter elements -- Verification of material compatibility with fluids

This Standard describes the method to verify the compatibility of materials with certain hydraulic fluids.

The test is carried out by keeping the element (the material sample) immersed in the fluid under high or low temperature conditions for a given period of time and verifying the retention of the characteristics.

ISO 3723

Hydraulic fluid power -- Filter elements -- Method for end load test

This Standard describes the method for verifying the axial load resistance of the filter elements.

After performing the procedure described in ISO 2943, the designed axial load is applied to the filter element. To verify the test results, then the test described in ISO 2941 is performed.

ISO 3968

Hydraulic fluid power -- Filters -- Evaluation of differential pressure versus flow characteristics

This Standard describes the method for checking the pressure drop across the filter.

The test is carried out by crossing the filter from a given fluid and by detecting upstream and downstream pressures.

Some of the parameters defined by the Standard are the fluid, the test temperature, the size of the tubes, the position of the pressure detection points.

ISO 16889

Hydraulic fluid power -- Filters -- Multi-pass method for evaluating filtration performance of a filter element

This Standard describes the method to check the filtration characteristics of the filter elements.

The test is performed by constant introduction of contaminant (ISO MTD). The characteristics observed during the test are the filtration efficiency and the dirty holding capacity related to the differential pressure.

ISO 23181

Hydraulic fluid power -- Filter elements -- Determination of resistance to flow fatigue using high viscosity fluid

This Standard describes the method for testing the fatigue resistance of the filter elements. The test is carried out by subjecting the filter to continuous flow variations, thus differential pressure, using a high viscosity fluid.

ISO 11170

Hydraulic fluid power -- Sequence of tests for verifying performance characteristics of filter elements

The Standard describes the method for testing the performance of filter elements. The protocol described by the regulations provides the sequence of all the tests described above in order to verify all the working characteristics (mechanical, hydraulic and filtration).

ISO 10771-1

Hydraulic fluid power -- Fatigue pressure testing of metal pressure-containing envelopes -- Test method

This Standard describes the method to check the resistance of the hydraulic components with pulsing pressure.

It can be applied to all metal components (excluding tubes) subject to cyclic pressure used in the hydraulic field.

Filtered to perfection

Our mobile filtration units provide the perfect solution for the oil maintenance of your lubrication and hydraulic fluids in off-line filtration applications.

Benefits:

- **Versatile and compact design**
- **Filtering and continuous cleaning of systems**
- **Removal of water from hydraulic systems (when fitted with a spin on filter)**
- **Particle counting to determine the Contamination Class according to ISO 4406, NAS 1638, AS4059**

Applications:

- **For oil changes, initial filling and flushing cycles in hydraulic and lubrication systems**
- **Pulp and paper mill equipment**
- **Construction machinery**
- **Large central hydraulic power units**
- **Injection moulding equipment**
- **Stamping presses**

Mobile filtration units

UFM 015



UFM 041



UFM 051



UFM 091-181-919



FTU



UFM 015	page 103
UFM 041	113
UFM 051	119
UFM 091	125
UFM 181	131
UFM 919	137
FTU	143

UFM 015

Mobile filtration unit 15 l/min flow rate



Description

Mobile filtration units

The UFM 015 is a portable oil transfer/filtration unit, specifically designed for both filling/transferring hydraulic oils from containers to the hydraulic tank as well as filtering and cleaning hydraulic systems.

The unit utilizes 160 size cartridge style filter element, thus increasing the dirt holding capacity and granting low pressure drop of the unit.

The unit has the flexibility in being able to offer a wide range of medias and micron ratings to suit any application.

The unit is very compact and lightweight.

Features & Benefits

- Handle size
- Light
- Easy to use
- Easy maintenance
- Reliable
- Absolute filtration



Technical data

<p>Pump Gear pump</p>	<p>Weight 14.8 kg (32.6 lb)</p>
<p>Electric Motor 0.18 kW 230 V single phase electric motor</p>	<p>Dimensions See drawings</p>
<p>Flow (l/min) 15 l/min - 1450 r.p.m.</p>	<p>Protection Class IP55</p>
<p>Max. Operation Pressure 4.0 bar</p>	<p>Seal NBR</p>
<p>Viscosity range Min. operation 10 cSt Max. operation 200 cSt Max. only for cold start 400 cSt</p>	<p>Fluid Compatibility Mineral Oil - Other on request</p>
<p>Suction Filter Type Y filtration 500 µm</p>	<p>Suction hose lance DN18 length 2500 mm DN/OD20 length 400 mm</p>
<p>Filtration Rating See designation order for cartridge and filter elements</p>	<p>Pressure hose lance DN18 length 2500 mm DN/OD18 length 400 mm</p>
<p>Bypass valve Δp set Rating 3.5 bar</p>	<p>Equipment Visual clogging indicator (gauge)</p>
<p>Fluid Temperature From +5 °C to 60 °C</p>	<p>CE Standard</p>
<p>Ambient Temperature From +5 °C to 40 °C</p>	

The new concept of filtration



ELIXIR®

RFX 160 - RETURN FILTER

Lighter, easier to use, and kinder to the environment - MP Filtri's new ELIXIR low pressure concept filters have been specially designed for in-line connections and to handle working pressures up to 1.6 MPa (16 bar).

The cast aluminum head and polyamide bowl design reduces weight by 10% compared to the Spin-on range.

Less waste reduces both your carbon footprint and protects the environment. Replacement is fast and easy, just disassemble the bowl with a 32 mm fixed wrench, take out the FEX filter element and replace.

Dimensions

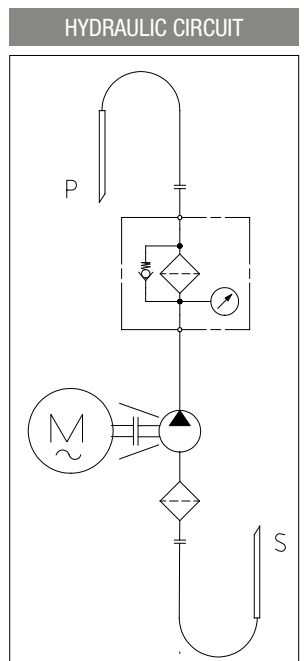
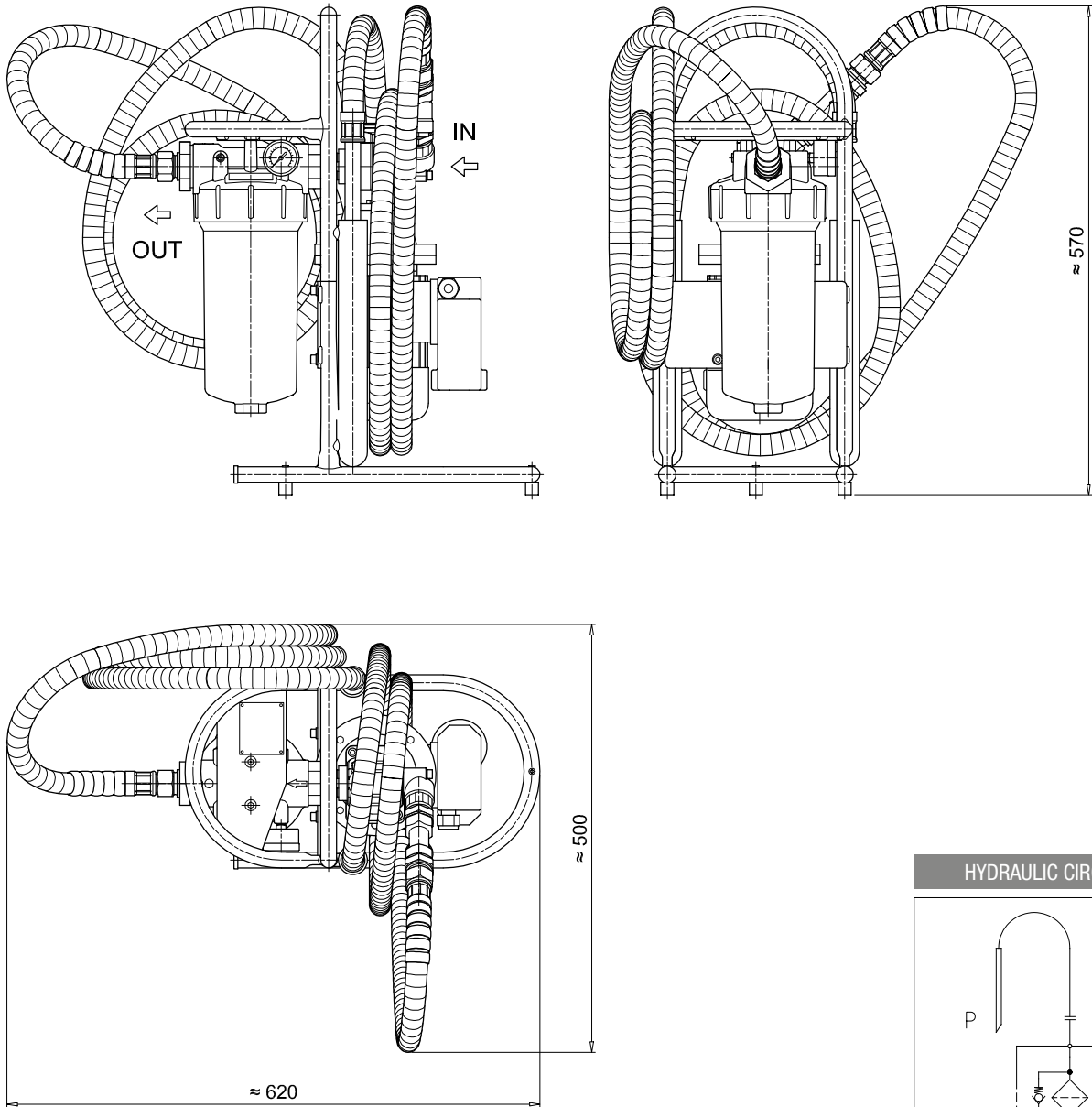

Dimensions

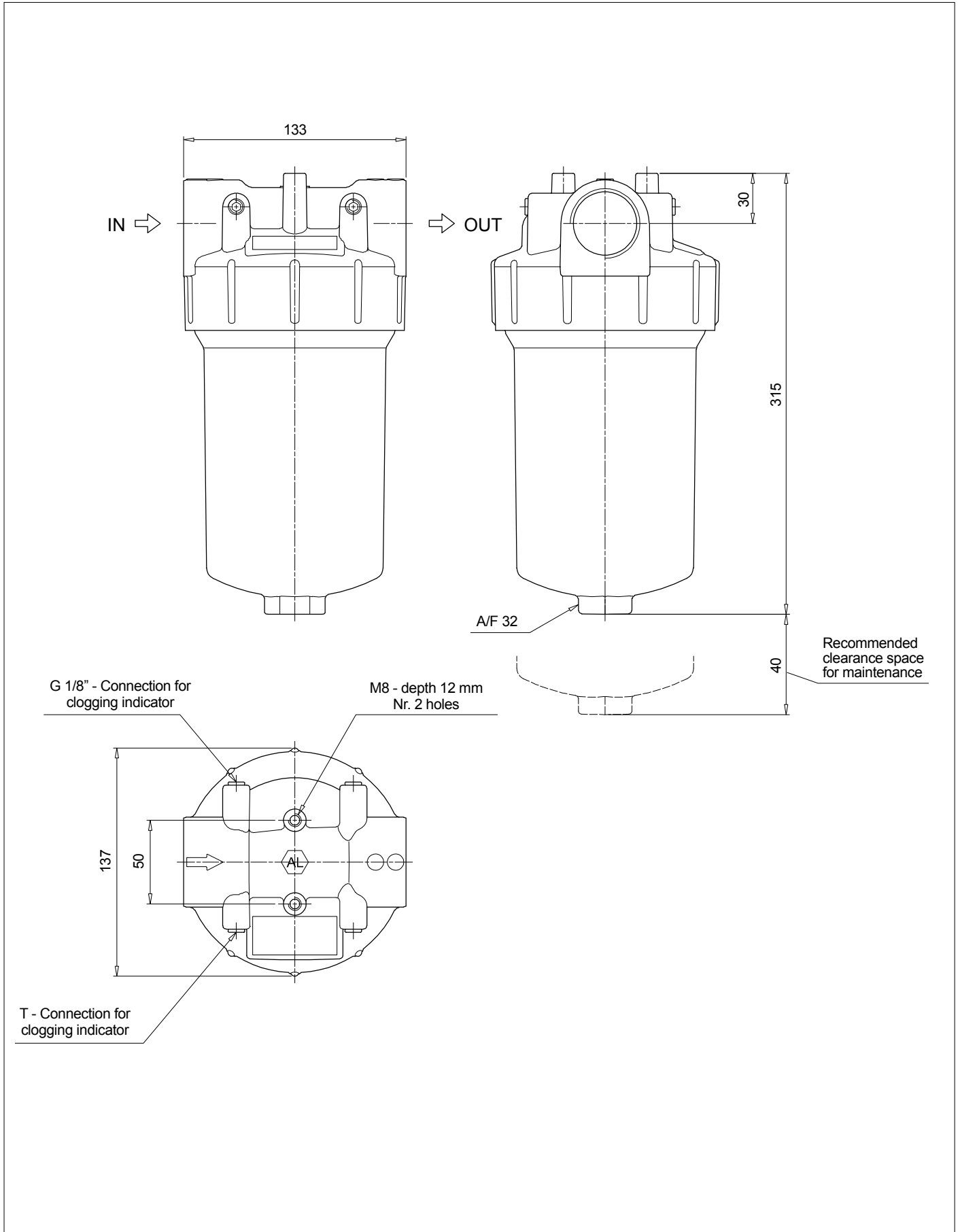

Order number for spare parts

Filter element detail

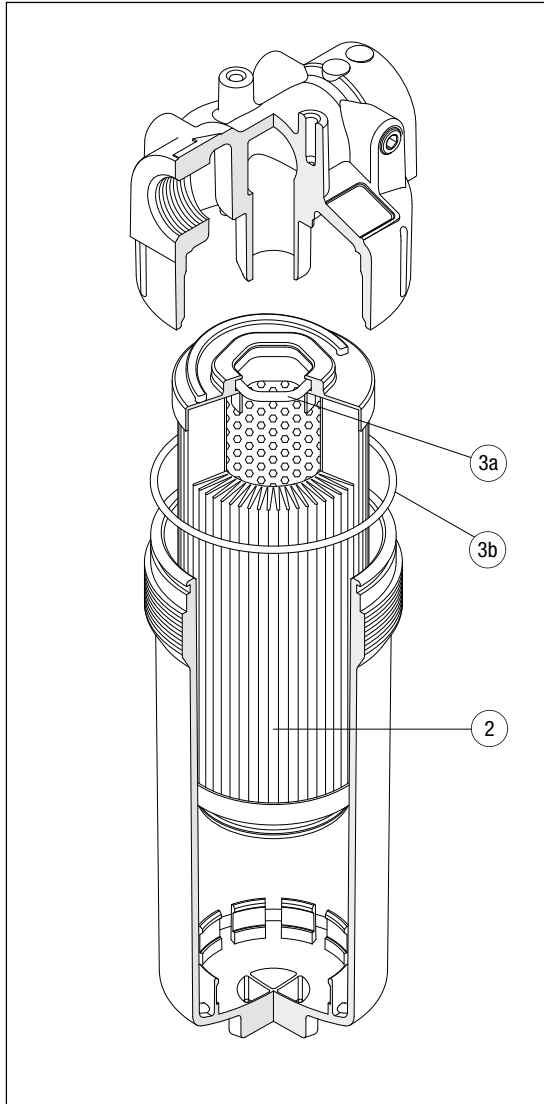

Mobile filtration Unit

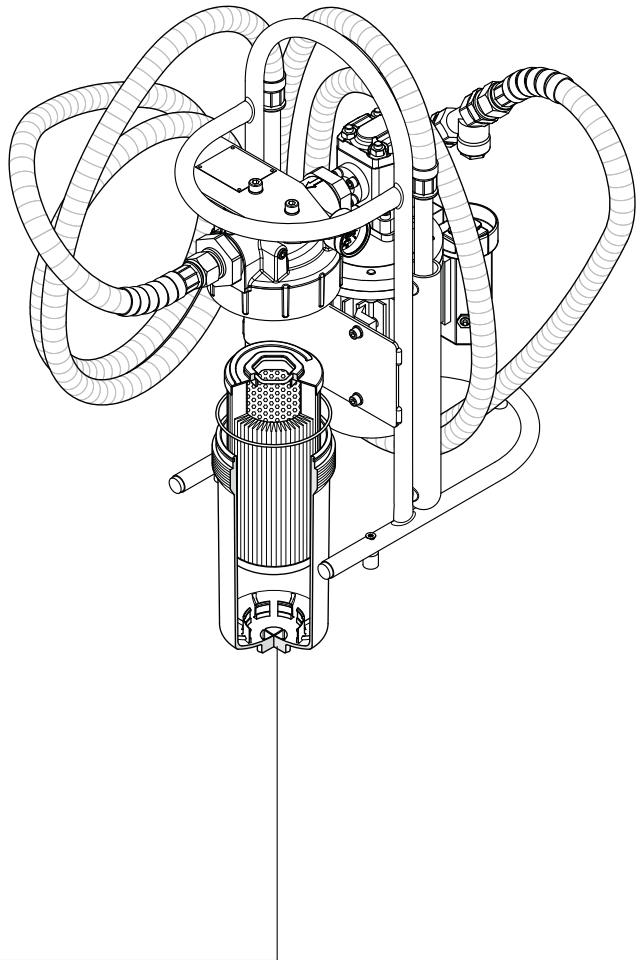

Item:	Q.ty: 1 pc.		Q.ty: 1 pc.		
Filter series	Filter element	Seal Kit code number NBR	FPM	Filter element seal	Bowl seal
RFEX 160	See spare parts (position 7)	02050772*	02050774	Hex Ring Private dimensions	O-Ring 3425 di = 107.62 - d ₂ = 2.62
		*included with filter element			

Dimensions

BVA		Hydraulic symbol	Materials
Axial Pressure Gauge			
Settings	Ordering code		<ul style="list-style-type: none"> - Case: Painted Steel - Window: Clear plastic - Dial: Painted Steel - Pointer: Black plastic - Pressure connection: Brass - Pressure element: Bourdon tube Cu-alloy soft soldered, C type
1.4 bar $\pm 10\%$	BV A 14 P01		
2.5 bar $\pm 10\%$	BV A 25 P01	<p>Dial scale</p> <p>BV A 14 P01</p> <p>BV A 25 P01</p>	
			<p>Technical data</p> <ul style="list-style-type: none"> - Max working pressure: Static: 7 bar Fluctuating: 6 bar Short time: 10 bar - Working temperature: Ambient from -40 °C to +60 °C Fluid max +60 °C - Compatibility with fluids: Mineral oils, Synthetic fluids HFA, HFB, HFC according to ISO 2943 - Accuracy: Class 2.5 according to EN 13190 - Degree of protection: IP31 according to EN 60529

UFM 041

Mobile filtration unit 34 l/min flow rate



Description

Mobile filtration units

UFM 041 mobile filtration units suitable for filling and refilling of filtered hydraulic fluids and lubrication tanks.

The filter unit connected to off-line to the tank (recommended maximum volume of 350/500 L.), can be used as a support to the filtration plant on start-up for fast flushing action, either as additional filtration systems with a high incidence of contamination.

Continued use is recommended for the version with three phase electric motor.

Features & Benefits

- Compact size
- Light
- Easy to use
- Easy maintenance
- Reliable
- Absolute filtration



Technical data

Pump

Gear pump

Electric Motor

0.75 kW 230 V single phase electric motor

0.75 kW 400 V three phase electric motor

Flow (l/min)

34 l/min - 1450 r.p.m.

Operation Pressure

Maximum: 5.0 bar

Viscosity range

Min. operation 10 cSt

Max. operation 200 cSt

Max. only for cold start 800 cSt

Suction Filter

Type Y filtration 350 µm

Filtration Rating

See designation order for cartridge and filter elements

Bypass valve Δp set

Rating 3 bar

Fluid Temperature

From -10 °C to +80 °C

Ambient Temperature

From -20 °C to +45 °C

Weight

45 kg (99.2 lb)

Dimensions

See drawings

Protection Class

IP55

Seal

NBR

Fluid Compatibility

Mineral Oil & Synthetic Oil - Other on request

Suction hose

DN25 length 3000 mm

lance

DN/OD25 length 700 mm

Pressure hose

DN20 length 3000 mm

lance

DN/OD20 length 700 mm

Equipment

Visual clogging indicator (gauge)



Dimensions

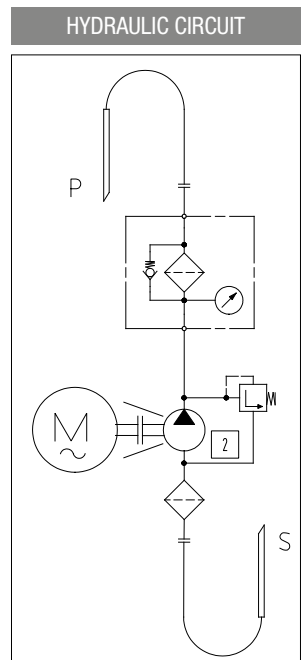
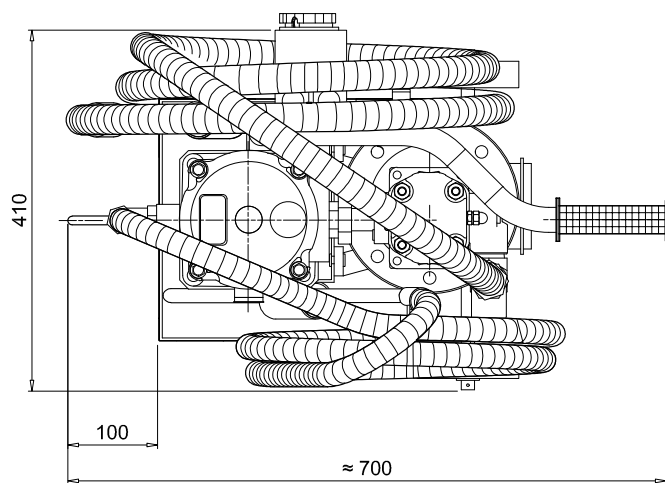
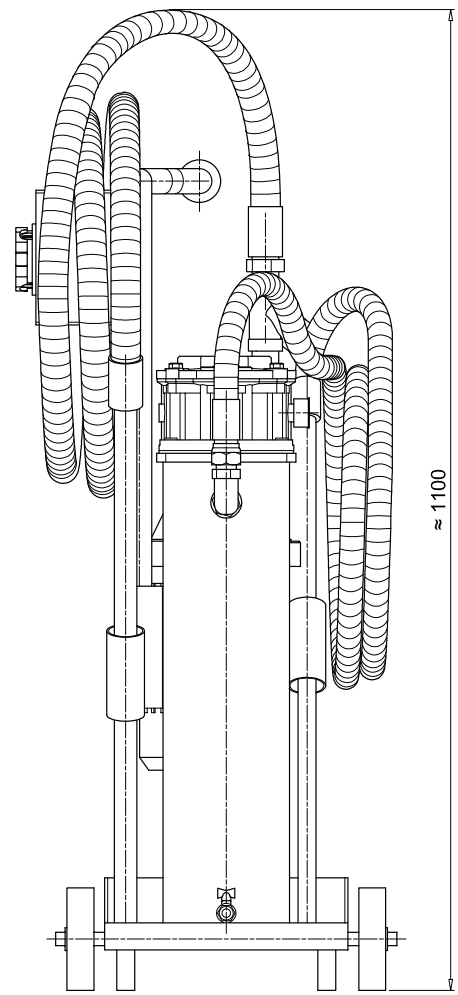
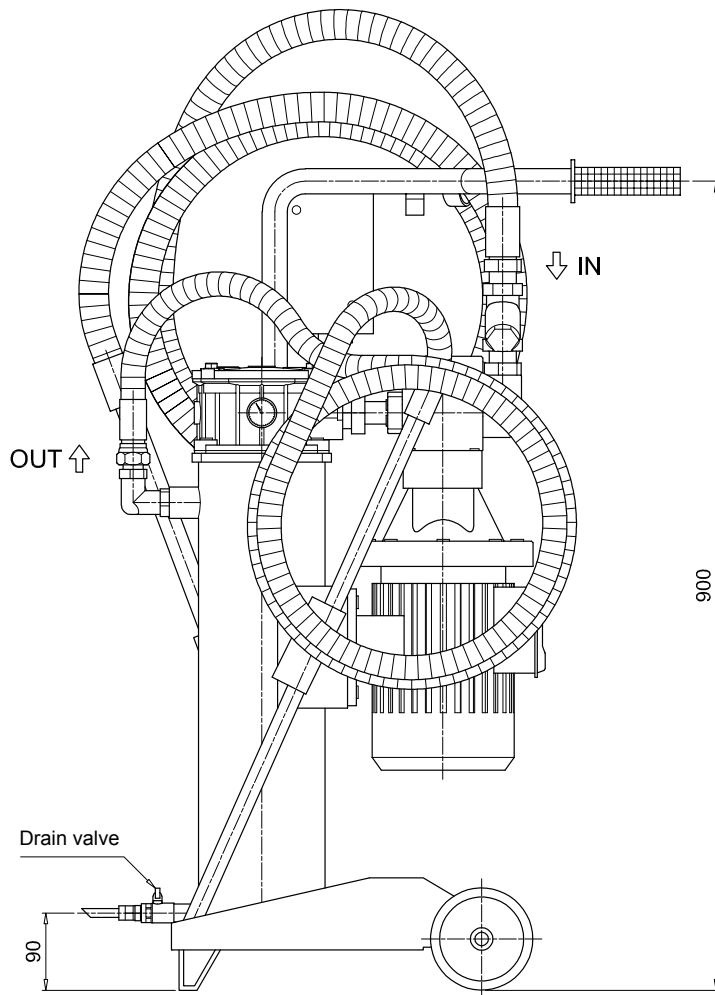

UFM 051

Mobile filtration unit 50 l/min flow rate



Description

Mobile filtration units

UFM 051 mobile filtration units suitable for filling and refilling of filtered hydraulic fluids and lubrication tanks.

The filter unit connected to off-line to the tank (recommended maximum volume of 500/750 L.), can be used as a support to the filtration plant on start-up for fast flushing action, either as additional filtration systems with a high incidence of contamination.

Continued use is recommended for the version with three phase electric motor.

Features & Benefits

- Compact size
- Continue Operation Pressure 10 bar
- Easy to use
- Easy maintenance
- Reliable
- Absolute filtration
- In-line Contamination Monitor

Available in three configurations:

- configuration with start / stop differential pressure indicator - visual
- configuration with start / stop automatic motor
- cut-out from differential pressure indicator - electrical / visual
- configuration with start / stop phase inverter automatic motor
- cut-out from differential pressure indicator - electrical / visual
- in-line Particle Counter ICM



Technical data

Pump

Gear pump

Electric Motor

1.5 kW 230 V single phase electric motor
1.5 kW 400 V three phase electric motor with ICM 2.0

Flow (l/min)

50 l/min - 1450 r.p.m.

Operation Pressure

Maximum: 10 bar

Viscosity range

Min. operation 10 cSt
Max. operation 300 cSt
Max. only for cold start 800 cSt

Suction Filter

Type Y filtration 800 µm

Filtration Rating

See designation order for cartridge and filter elements

Bypass valve Δp set

Rating 3.5 bar
The bypass can be blocked through the spigot

Fluid Temperature

From -10 °C to +80 °C

Ambient Temperature

From -20 °C to +45 °C

Weight

70 kg (154.3 lb)

Dimensions

See drawings

Protection Class

IP55

Fluid Compatibility

Mineral Oil & Synthetic Oil - Other on request

Suction hose

DN32 length 3000 mm

lance

DN/OD42 length 700 mm

Pressure hose

DN25 length 3000 mm

lance

DN/OD30 length 700 mm

Equipment

- Differential Clogging indicator - Visual (setting 3.0 bar $\pm 10\%$)
- Differential Clogging indicator - Electrical / Visual (setting 3.0 bar $\pm 10\%$)
- Differential Clogging indicator - Electrical / Visual - with ICM 2.0 (setting 3.0 bar $\pm 10\%$)

CE Standard

UFM 051

Designation & Ordering code

MOBILE FILTRATION UNIT UFM 051										
Series	Configuration example: UFM 051 T A 2 0 1 0 P01									
UFM										
Size	051 50 l/min									
Electric motor	M 230 V Single phase T 400 V Three phase									
Seals	A NBR									
Pressure gauges and clogging indicators (see below)	particle counter option									
	0	1								
2 Manometer (*) + Visual diff. clogging indicator	•	-								
3 Manometer (*) + Electrical diff. clogging indicator (visual indication on panel)	•	•								
Filter element	0 Without element (for ordering, see below)									
Filtration surface	1 Standard 2 Higher									
Particle counter option	Electric motor									
	M	T								
0 Without ICM	•	•								
1 With ICM 2.0	•	•								
	Option									
	P01 MP Filtri standard									
	Pxx Customized									

Filtration element should be ordered separately

FILTRATION SURFACE 1 - STANDARD

Inorganic microfibre		Wire mesh element	
CU 400 5 A01 A N P01	01 µm	CU 400 5 M25 A N P01	25 µm
CU 400 5 A03 A N P01	03 µm	CU 400 5 M60 A N P01	60 µm
CU 400 5 A06 A N P01	06 µm		
CU 400 5 A10 A N P01	10 µm		
CU 400 5 A16 A N P01	16 µm		
CU 400 5 A25 A N P01	25 µm		

WATER REMOVAL

Multi-Layer water absorber	
CU4005WA025ANP01	25 µm

FILTRATION SURFACE 2 - HIGHER

Inorganic microfibre		Wire mesh element	
CU 400 6 A01 A N P01	01 µm	CU 400 6 M25 A N P01	25 µm
CU 400 6 A03 A N P01	03 µm	CU 400 6 M60 A N P01	60 µm
CU 400 6 A06 A N P01	06 µm		
CU 400 6 A10 A N P01	10 µm		
CU 400 6 A16 A N P01	16 µm		
CU 400 6 A25 A N P01	25 µm		

WATER REMOVAL

Multi-Layer water absorber	
CU4006WA025ANP01	25 µm

CLOGGING INDICATORS (*)

DVM Visual Differential Indicator

Settings	Ordering code
3.0 bar ±10%	DV M 30 P01

DEA Electrical Differential Indicator (visual indication on panel)

Settings	Ordering code
3.0 bar ±10%	DE A 30 P01

Dimensions

Filter length	H1 [mm]
1	1230 standard
2	1530 higher

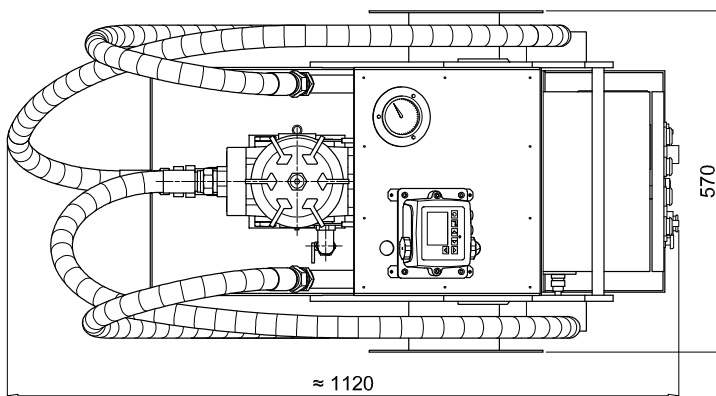
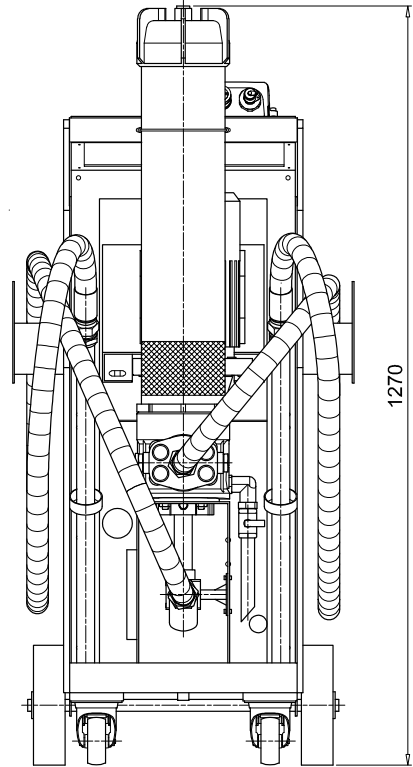
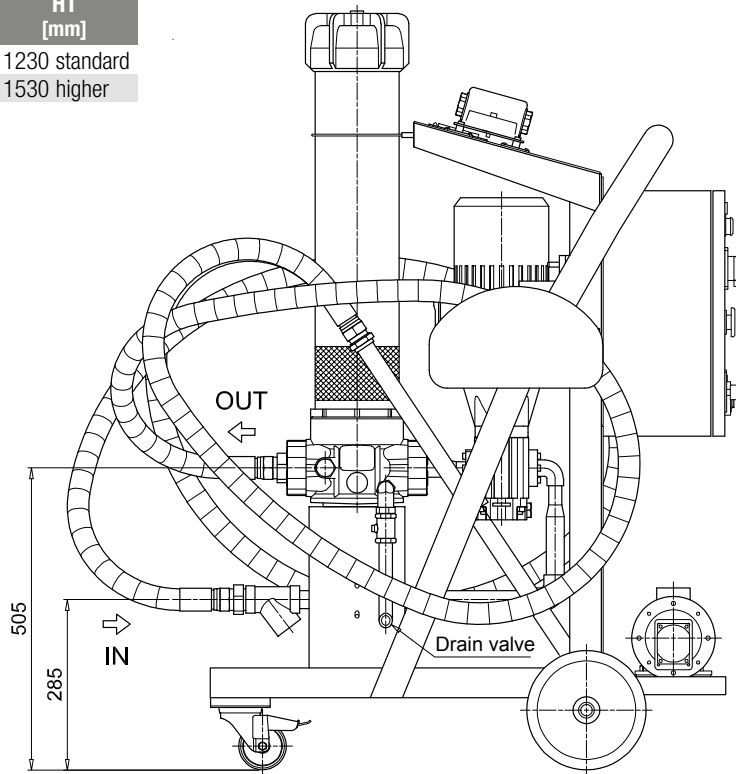

HYDRAULIC CIRCUIT

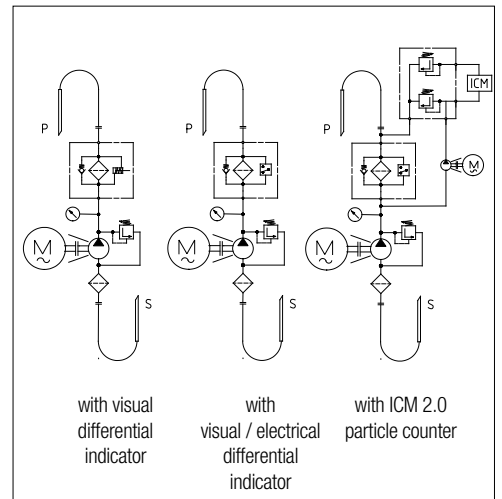

UFM 091

Mobile filtration unit 90 l/min flow rate



Description

Mobile filtration units

UFM 091 mobile filtration units suitable for filling and refilling of filtered hydraulic fluids and lubrication tanks.

The filter unit connected to off-line to the tank, can be used as a support to the filtration plant on start-up for fast flushing action, either as additional filtration systems with a high incidence of contamination. Recommended maximum tank volume of 1500/1800L.

Features & Benefits

- Compact size
- High flow
- Continue Operation Pressure 10 bar
- Easy to use
- Easy maintenance
- Reliable
- Absolute filtration
- In-line Contamination Monitor

Available in three configurations:

- configuration with start / stop differential pressure indicator - visual
- configuration with start / stop automatic motor
- cut-out from differential pressure indicator - electrical / visual
- configuration with start / stop phase inverter automatic motor
- cut-out from differential pressure indicator - electrical / visual
- in-line Particle Counter ICM



Technical data

Pump

Screw pump

Electric Motor

2.2 kW 400 V three phase 4-pole

Flow (l/min)

90 l/min - 1450 r.p.m.

Operation Pressure

Maximum: 10 bar

Viscosity range

Min. operation 10 cSt

Max. operation 800 cSt

Max. only for cold start 2000 cSt

Suction Filter

Type Y filtration 800 µm

Filtration Rating

See designation order for cartridge and filter elements

Bypass valve Δp set

Rating 3.5 bar with bypass.

The bypass can be blocked through the spigot

Fluid Temperature

From -10 °C to +80 °C

Ambient Temperature

From -20 °C to +45 °C

Weight

105 kg (231.5 lb)

Dimensions

See drawings

Protection Class

IP55

Seal

NBR

Fluid Compatibility

Mineral Oil & Synthetic Oil - Water Glycol

Suction hose

DN50 length 3000 mm

lance

DN/OD50 length 700 mm

Pressure hose

DN38 length 3000 mm

lance

DN/OD42 length 700 mm

Equipment

- Differential Clogging indicator - Visual (setting 3.0 bar $\pm 10\%$)
- Differential Clogging indicator - Electrical / Visual (setting 3.0 bar $\pm 10\%$)
- Differential Clogging indicator - Electrical / Visual - with ICM 2.0 (setting 3.0 bar $\pm 10\%$)

CE Standard

Designation & Ordering code

MOBILE FILTRATION UNIT UFM 091										
Series UFM	Configuration example:	UFM	091	T	A	2	0	2	0	P01
Size 091 90 l/min										
Electric motor T 400 V Three phase										
Seals A NBR										
Pressure gauges and Clogging indicators (see below)										
2	Manometer (*) + Visual differential clogging indicator									
3	Manometer (*) + Electrical diff. clogging indicator (visual indication on panel)									
Filter element 0 Without element (for ordering, see below)										
Filtration surface 2 Higher										
Option										
0	No options									
1	ICM 2.0 particle counter									
Option										
P01	MP Filtri standard									
Pxx	Customized									

Filtration element should be ordered separately

FILTRATION SURFACE - HIGHER			
Inorganic microfibre		Wire mesh element	
CU 400 6 A01 A N P01	01 µm	CU 400 6 M25 A N P01	25 µm
CU 400 6 A03 A N P01	03 µm	CU 400 6 M60 A N P01	60 µm
CU 400 6 A06 A N P01	06 µm		
CU 400 6 A10 A N P01	10 µm		
CU 400 6 A16 A N P01	16 µm		
CU 400 6 A25 A N P01	25 µm		

WATER REMOVAL	
Multi-Layer water absorber	
CU4006WA025ANP01	25 µm

CLOGGING INDICATORS (*)

DVM Visual Differential Indicator		DEA Electrical Differential Indicator (visual indication on panel)	
Settings	Ordering code	Settings	Ordering code
3.0 bar ±10%	DV M 30 P01	3.0 bar ±10%	DE A 30 P01

Dimensions

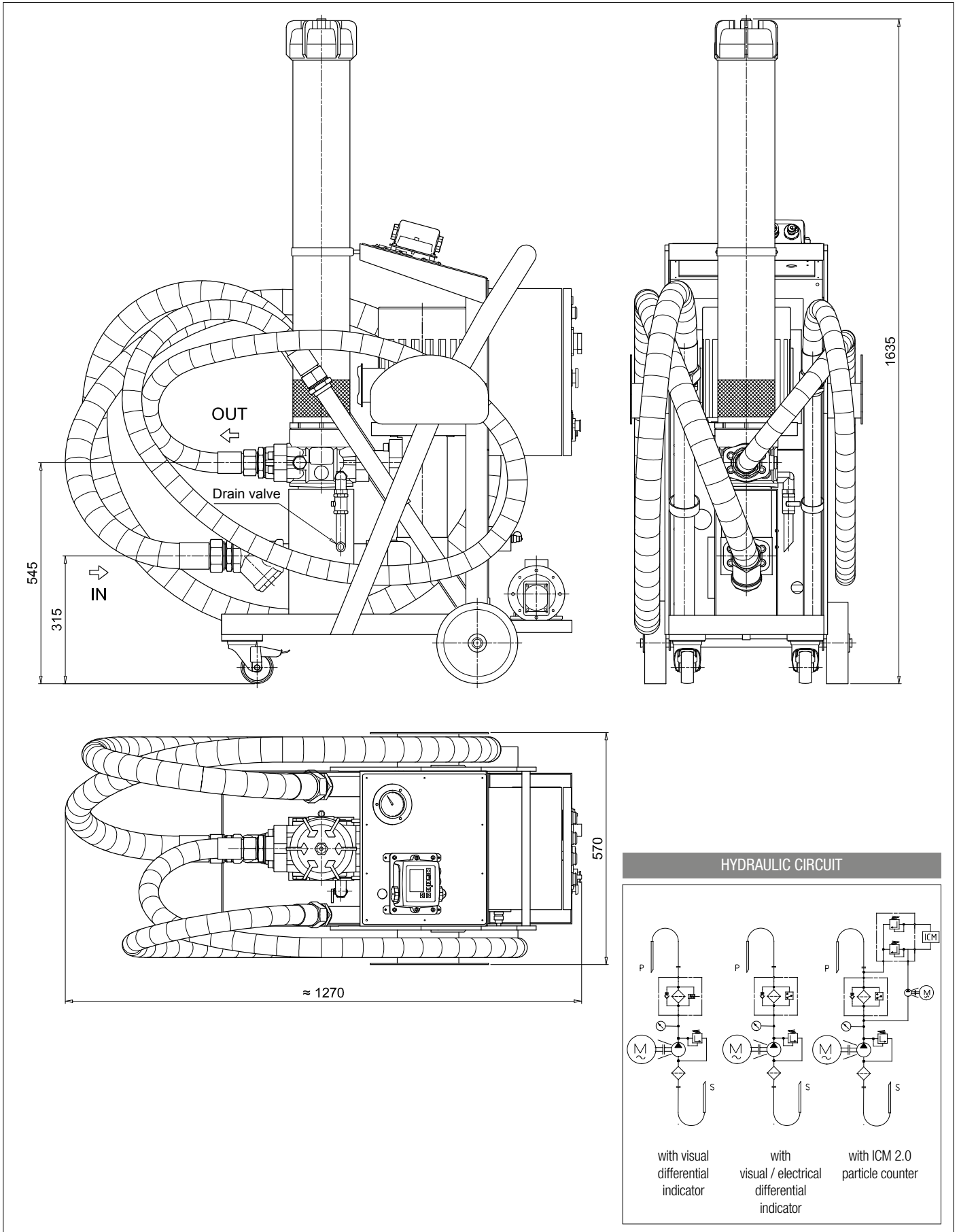

UFM 181

Mobile filtration unit 180 l/min flow rate



Description

Mobile filtration units

UFM 181 mobile filtration units suitable for filling and refilling of filtered hydraulic fluids and lubrication tanks.

The filter unit connected to off-line to the tank, can be used as a support to the filtration plant on start-up for fast flushing action, either as additional filtration systems with a high incidence of contamination. Recommended maximum tank volume of 1800/2700 L.

Features & Benefits

- Compact size
- High flow
- Continue Operation Pressure 10 bar
- Easy to use
- Easy maintenance
- Reliable
- Absolute filtration
- In-line Contamination Monitor

Available in two configurations:

- configuration with start / stop automatic motor
- cut-out from differential pressure indicator - electrical / visual
- configuration with start / stop phase inverter automatic motor
- cut-out from differential pressure indicator - electrical / visual
- in-line Particle Counter ICM



Technical data

<p>Pump Screw pump</p>	<p>Weight 109 kg (240.3)</p>
<p>Electric Motor 4 kW 400 V three phase 2-pole</p>	<p>Dimensions See drawings</p>
<p>Flow (l/min) 180 l/min - 2900 r.p.m.</p>	<p>Protection Class IP55</p>
<p>Operation Pressure Maximum: 10 bar</p>	<p>Seal NBR</p>
<p>Viscosity range Min. operation 10 cSt Max. operation 800 cSt Max. only for cold start 2000 cSt</p>	<p>Fluid Compatibility Mineral Oil & Synthetic Oil - Water Glycol</p>
<p>Suction Filter Type Y filtration 800 µm</p>	<p>Suction hose lance DN50 length 3000 mm DN/OD50 length 700 mm</p>
<p>Filtration Rating See designation order for cartridge and filter elements</p>	<p>Pressure hose lance DN38 length 3000 mm DN/OD42 length 700 mm</p>
<p>Bypass valve Δp set Rating 3.5 bar with bypass. The bypass can be blocked through the spigot</p>	<p>Equipment - Differential Clogging indicator - Electrical / Visual (setting 3.0 bar ±10%) - Differential Clogging indicator - Electrical / Visual - with ICM 2.0 (setting 3.0 bar ±10%)</p>
<p>Fluid Temperature From -10 °C to +80 °C</p>	<p>CE Standard</p>
<p>Ambient Temperature From -20 °C to +45 °C</p>	

UFM 181

Designation & Ordering code

MOBILE FILTRATION UNIT UFM 181	
Series UFM	Configuration example: UFM 181 T A 3 0 2 0 P01
Size 181 180 l/min	
Electric motor T 400 V Three phase	
Seals A NBR	
Pressure gauges and Clogging indicators (see below) 3 Manometer (*) + Electrical diff. clogging indicator (visual indication on panel)	
Filter element 0 Without element (for ordering, see below)	
Filtration surface 2 Higher	
Option 0 No options 1 ICM 2.0 particle counter	
Option P01 MP Filtri standard Pxx Customized	

Filtration element should be ordered separately

FILTRATION SURFACE - HIGHER	
Inorganic microfibre	Wire mesh element
CU 400 6 A01 A N P01 01 µm	CU 400 6 M25 A N P01 25 µm
CU 400 6 A03 A N P01 03 µm	CU 400 6 M60 A N P01 60 µm
CU 400 6 A06 A N P01 06 µm	
CU 400 6 A10 A N P01 10 µm	
CU 400 6 A16 A N P01 16 µm	
CU 400 6 A25 A N P01 25 µm	

WATER REMOVAL	
Multi-Layer water absorber	
CU4006WA025ANP01	25 µm

CLOGGING INDICATORS (*)

DEA Electrical Differential Indicator (visual indication on panel)

Settings	Ordering code
3.0 bar ±10%	DE A 30 P01

Dimensions

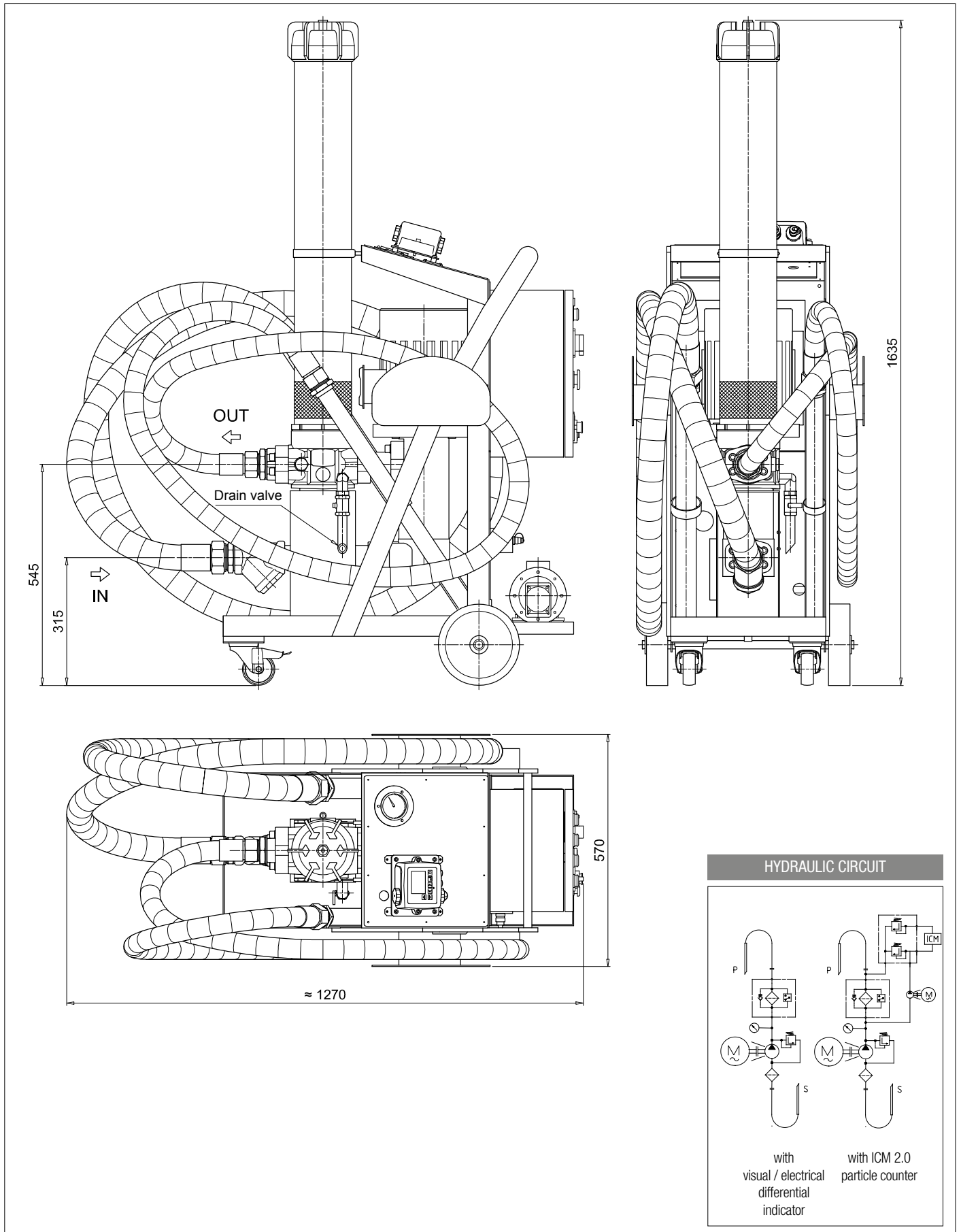

UFM 919

Mobile filtration unit 90/180 l/min flow rate



Description

Mobile filtration units

UFM 919 mobile filtration units suitable for filling and refilling of filtered hydraulic fluids and lubrication tanks.

The filter unit connected to off-line to the tank, can be used as a support to the filtration plant on start-up for fast flushing action, either as additional filtration systems with a high incidence of contamination. Two-speed electric motor with programmable flow of 90 or 180 l/min.

Features & Benefits

- Compact size
- High flow
- Continue Operation Pressure 10 bar
- Easy to use
- Easy maintenance
- Reliable
- Absolute filtration
- In-line Contamination Monitor

Available in two configurations:

- configuration with start / stop automatic motor
- cut-out from differential pressure indicator - electrical / visual
- configuration with start / stop phase inverter automatic motor
- cut-out from differential pressure indicator - electrical / visual
- in-line Particle Counter ICM 2.0

Possible applications

Flow rate 90 l/min:

- for filling or topping up tanks with a volume of less than 1000 liters
- for depollution of tanks with a volume of less than 1000 liters
- for the treatment of high viscosity oils
- for a cold start phase then flow rate 180 l/min after temperature rise.

Flow rate 180 l/min:

- for filling or topping up tanks with a volume greater than 2000 liters
- for the depollution of tanks with a volume of less than 2000 liters



Technical data

<p>Pump Screw pump</p>	<p>Weight 120 kg (264.5 lb)</p>
<p>Electric Motor 3.7/5 kW 400 V three phase 2/4-pole</p>	<p>Dimensions See drawings</p>
<p>Flow (l/min) 90 l/min - 1450 r.p.m. / 180 l/min - 2900 r.p.m.</p>	<p>Protection Class IP55</p>
<p>Operation Pressure Maximum: 10 bar</p>	<p>Seal NBR DN/OD40 length 700 mm</p>
<p>Viscosity range Min. operation 10 cSt Max. operation 800 cSt Max. only for cold start 2000 cSt</p>	<p>Fluid Compatibility Mineral Oil & Synthetic Oil - Water Glycol</p>
<p>Suction Filter Type Y filtration 800 µm</p>	<p>Suction hose lance lance 90° DN50 length 3000 mm DN/OD50 length 700 mm</p>
<p>Filtration Rating See designation order for cartridge and filter elements</p>	<p>Pressure hose lance DN38 length 3000 mm DN/OD42 length 700 mm</p>
<p>Bypass valve Δp set Rating 3.5 bar with bypass. The bypass can be blocked through the spigot</p>	<p>Equipment - Differential Clogging indicator - Electrical / Visual (setting 3.0 bar ±10%) - Differential Clogging indicator - Electrical / Visual - with ICM 2.0 (setting 3.0 bar ±10%)</p>
<p>Fluid Temperature From -10 °C to +80 °C</p>	<p>CE Standard</p>
<p>Ambient Temperature From -20 °C to +45 °C</p>	

UFM 919

Designation & Ordering code

MOBILE FILTRATION UNIT UFM 919										
Series UFM	Configuration example: UFM 919 T A 3 0 2 0 P01									
Size 919 90-180 l/min										
Electric motor T 400 V Three phase - 2/4 pole										
Seals A NBR										
Pressure gauges and Clogging indicators (see below) 3 Manometer (*) + Electrical diff. clogging indicator (visual indication on panel)										
Filter element 0 Without element (for ordering, see below)										
Filtration surface 2 Higher										
Option 0 No options 1 ICM 2.0 particle counter										
Option P01 MP Filtri standard Pxx Customized										

Filtration element should be ordered separately

FILTRATION SURFACE - HIGHER			
Inorganic microfibre		Wire mesh element	
CU 400 6 A01 A N P01	01 µm	CU 400 6 M25 A N P01	25 µm
CU 400 6 A03 A N P01	03 µm	CU 400 6 M60 A N P01	60 µm
CU 400 6 A06 A N P01	06 µm		
CU 400 6 A10 A N P01	10 µm		
CU 400 6 A16 A N P01	16 µm		
CU 400 6 A25 A N P01	25 µm		

WATER REMOVAL	
Multi-Layer water absorber	
CU4006WA025ANP01	25 µm

CLOGGING INDICATORS (*)

DEA Electrical Differential Indicator (visual indication on panel)

Settings	Ordering code
3.0 bar ±10%	DE A 30 P01

Dimensions

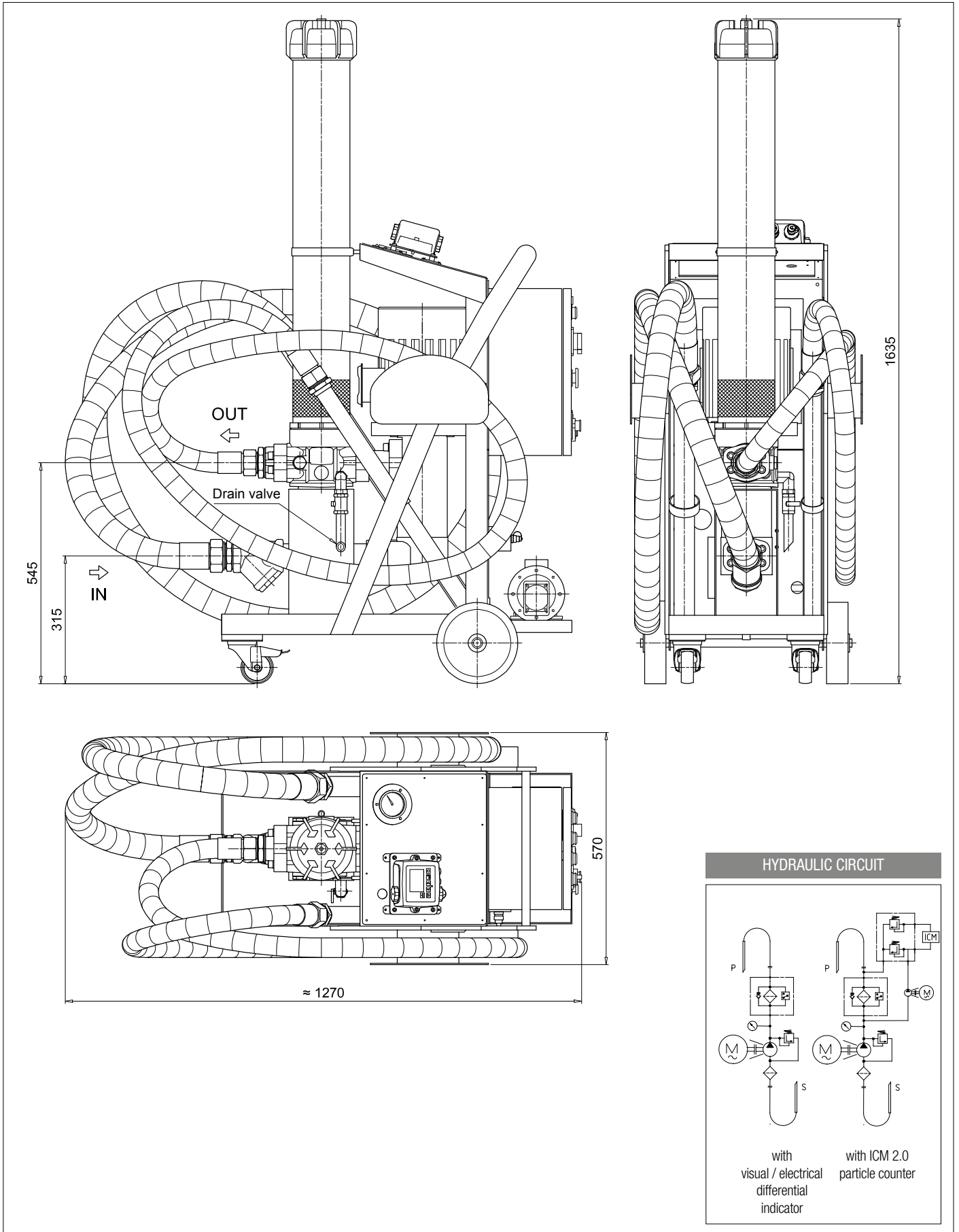

FTU

Fluid transfer unit with ICM 2.0 / 4.0 (In-line Contamination Monitor)



Description

Fluid Transfer Unit

The FTU Fluid Transfer Unit is suitable for filling, recirculation (via the onboard reservoir), and emptying of filtered hydraulic fluids and lubrication tanks.

The FTU can be utilised either as additional filtration to a system with a high incidence of contamination, or it can be used as a standalone recirculation filtration circuit to clean fluid to a predetermined contamination level (monitored by the onboard ICM device) prior to the transfer of fluid to the system.

Features & Benefits

- Compact size
- Easy to use
- Easy maintenance
- Reliable
- Absolute filtration
- In-line Contamination monitor equipped

Possible applications

- Low flow rate for filling reservoirs
- Low-flow filtration for off-line tanks
- Pre filtration ability of fluid prior to filling of hydraulic system



Technical data

Pump

Gear pump

Electric Motor

0.75 kW 1400 rpm, 110/230 V single phase

Flow

15 l/min (3.96 gpm)

Operation Pressure

Maximum: 3.5 bar (51 psi)

Inlet

Inlet (pump protection) filtration steel 250 µm strainer

Viscosity

150 cSt maximum fluid viscosity

Suction Filter

250 µm metal mesh strainers

Bypass valve Δp set

Rating 3.5 bar (51 psi) with bypass

Filtration

Water removal "spin-on" type, bypass set at 1.75 bar (25.4 psi)

In-line filtration 3 µm absolute $\beta_{x(c)} > 1000$ element bypass set at 3.0 bar (44 psi)**Filtration rating**

See designation order for cartridge and filter elements

Control

Electrical Control Box

Indicator

Delivery line electric cut out switch

Weight

200 kg (440.9 lb)

Dimensions

See drawings

Ambient Temperature

From -10 °C to +80 °C (from -14 °F to +176 °F)

Working temperature

From 0°C to +40 °C (from 32 °F to +104°F)

Protection Class

IP55

Seal

NBR

Fluid Compatibility

Mineral oil compatible - please contact sales team for queries about other fluids

Hoses

Flexible hoses - SAE100R4 1" BSP swaged females 2 m long hose

Oil level

Sight glass and filler with integrated electric float cut out switch

Mounting

Heavy duty trolley and wheels

CE Standard

Designation & Ordering code

FLUID TRANSFER UNIT FTU

Mobile filtration unit		Configuration example:							
FTU Fluid Transfer Unit		FTU	1	1	15	2	1	M250	SL4305
Onboard reservoir									
1	100 litres - Aluminium								
2	50 litres - Aluminium								
3	100 litres - Stainless steel								
4	50 litres - Stainless steel								
In-line contamination monitor									
1	With ICM 2.0								
2	With ICM 4.0								
Flow rate									
15	15 l/min								
Motor power									
2	0.75 kW, 1400 rpm								
Voltage									
1	110 V - 50 Hz single phase								
2	240 V - 50 Hz single phase								
Inlet filtration									
M250	250 µm suction strainer (internal of reservoir)								
Outlet filtration									
SL4305	Single spin on plus LMP length 5								

Filtration element is not included and should be ordered separately.

Outlet filtration options:

LMP: CU400 5 A03, A06, A10, A16, A25 - **SPIN-ON:** CS150 A03, A06, A10, A25 - CS150 P10, P25 - **WATER REMOVAL:** CW150 P10, P25

CARTRIDGE STANDARD LENGTH

Inorganic microfibre		Wire mesh element	
CS 100 A01 A P01	01 µm	CS 100 M25 A P01	25 µm
CS 100 A03 A P01	03 µm	CS 100 M60 A P01	60 µm
CS 100 A06 A P01	06 µm		
CS 100 A10 A P01	10 µm		
CS 100 A25 A P01	25 µm		

CARTRIDGE EXTENDED LENGTH

Inorganic microfibre		Wire mesh element	
CS 150 A01 A P01	01 µm	CS 150 M25 A P01	25 µm
CS 150 A03 A P01	03 µm	CS 150 M60 A P01	60 µm
CS 150 A06 A P01	06 µm		
CS 150 A10 A P01	10 µm		
CS 150 A25 A P01	25 µm		

LMP FILTER ELEMENT - LENGTH 5

Inorganic microfibre	
CU 400 5 A03 A N P01	03 µm
CU 400 5 A10 A N P01	10 µm
CU 400 5 A16 A N P01	16 µm
CU 400 5 A25 A N P01	25 µm

WATER REMOVAL - CARTRIDGE EXTENDED LENGTH

Multi-Layer water absorber	
CW 150 P10 A	10 µm

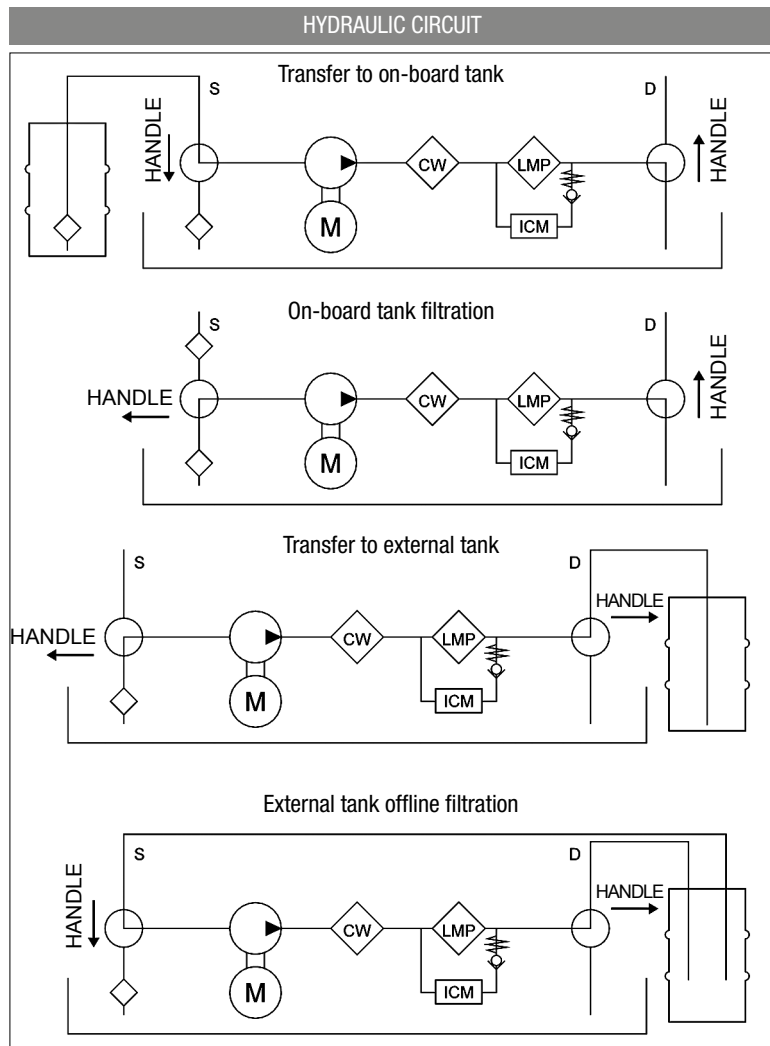
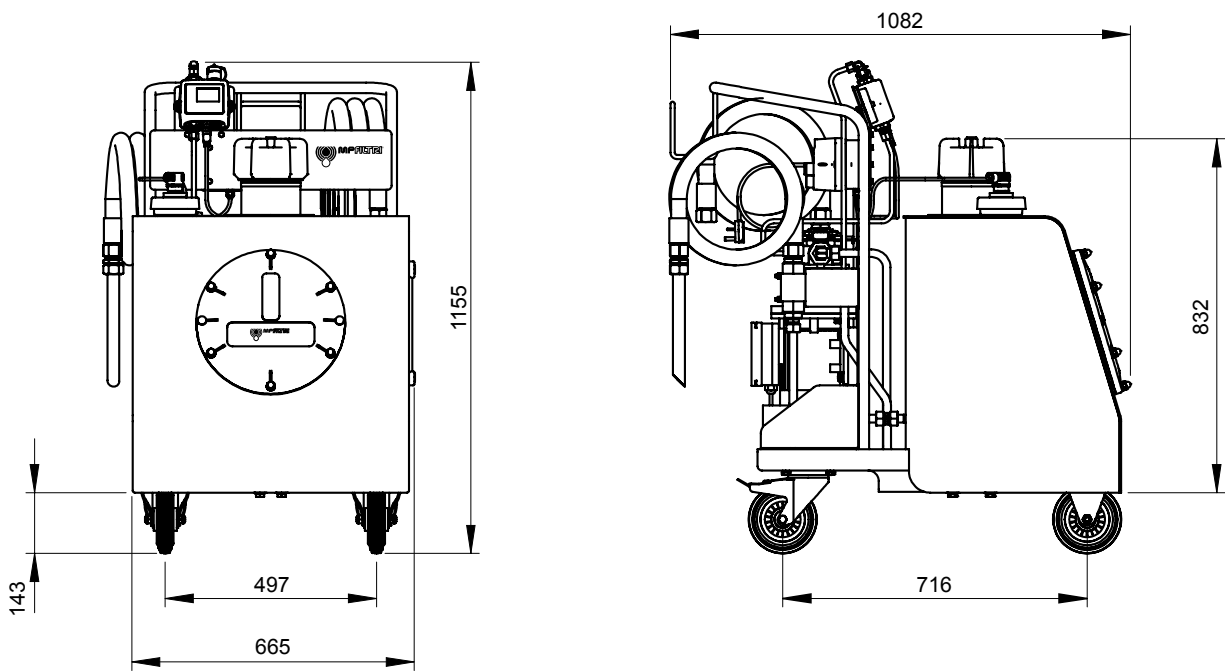



Алматы (727)345-47-04
Ангарск (3955)60-70-56
Архангельск (8182)63-90-72
Астрахань (8512)99-46-04
Барнаул (3852)73-04-60
Белгород (4722)40-23-64
Благовещенск (4162)22-76-07
Брянск (4832)59-03-52
Владивосток (423)249-28-31
Владикавказ (8672)28-90-48
Владимир (4922)49-43-18
Волгоград (844)278-03-48
Вологда (8172)26-41-59
Воронеж (473)204-51-73
Екатеринбург (343)384-55-89

Россия +7(495)268-04-70

Иваново (4932)77-34-06
Ижевск (3412)26-03-58
Иркутск (395)279-98-46
Казань (843)206-01-48
Калининград (4012)72-03-81
Калуга (4842)92-23-67
Кемерово (3842)65-04-62
Киров (8332)68-02-04
Коломна (4966)23-41-49
Кострома (4942)77-07-48
Краснодар (861)203-40-90
Красноярск (391)204-63-61
Курск (4712)77-13-04
Курган (3522)50-90-47
Липецк (4742)52-20-81

Казахстан +7(727)345-47-04

Магнитогорск (3519)55-03-13
Москва (495)268-04-70
Мурманск (8152)59-64-93
Набережные Челны (8552)20-53-41
Нижегород (831)429-08-12
Новокузнецк (3843)20-46-81
Ноябрьск (3496)41-32-12
Новосибирск (383)227-86-73
Омск (3812)21-46-40
Орел (4862)44-53-42
Оренбург (3532)37-68-04
Пенза (8412)22-31-16
Петрозаводск (8142)55-98-37
Псков (8112)59-10-37
Пермь (342)205-81-47

Беларусь +(375)257-127-884

Ростов-на-Дону (863)308-18-15
Рязань (4912)46-61-64
Самара (846)206-03-16
Санкт-Петербург (812)309-46-40
Саранск (8342)22-96-24
Саратов (845)249-38-78
Севастополь (8692)22-31-93
Симферополь (3652)67-13-56
Смоленск (4812)29-41-54
Сочи (862)225-72-31
Ставрополь (8652)20-65-13
Сургут (3462)77-98-35
Сыктывкар (8212)25-95-17
Тамбов (4752)50-40-97
Тверь (4822)63-31-35

Узбекистан +998(71)205-18-59

Тольятти (8482)63-91-07
Томск (3822)98-41-53
Тула (4872)33-79-87
Тюмень (3452)66-21-18
Улан-Удэ (3012)59-97-51
Ульяновск (8422)24-23-59
Уфа (347)229-48-12
Хабаровск (4212)92-98-04
Чебоксары (8352)28-53-07
Челябинск (351)202-03-61
Череповец (8202)49-02-64
Чита (3022)38-34-83
Якутск (4112)23-90-97
Ярославль (4852)69-52-93

Киргизия +996(312)96-26-47