

Алматы (727)345-47-04
Ангарск (3955)60-70-56
Архангельск (8182)63-90-72
Астрахань (8512)99-46-04
Барнаул (3852)73-04-60
Белгород (4722)40-23-64
Благовещенск (4162)22-76-07
Брянск (4832)59-03-52
Владивосток (423)249-28-31
Владикавказ (8672)28-90-48
Владимир (4922)49-43-18
Волгоград (844)278-03-48
Вологда (8172)26-41-59
Воронеж (473)204-51-73
Екатеринбург (343)384-55-89

Иваново (4932)77-34-06
Ижевск (3412)26-03-58
Иркутск (395)279-98-46
Казань (843)206-01-48
Калининград (4012)72-03-81
Калуга (4842)92-23-67
Кемерово (3842)65-04-62
Киров (8332)68-02-04
Коломна (4966)23-41-49
Кострома (4942)77-07-48
Краснодар (861)203-40-90
Красноярск (391)204-63-61
Курск (4712)77-13-04
Курган (3522)50-90-47
Липецк (4742)52-20-81

Магнитогорск (3519)55-03-13
Москва (495)268-04-70
Мурманск (8152)59-64-93
Набережные Челны (8552)20-53-41
Нижний Новгород (831)429-08-12
Новокузнецк (3843)20-46-81
Ноябрьск (3496)41-32-12
Новосибирск (383)227-86-73
Омск (3812)21-46-40
Орел (4862)44-53-42
Оренбург (3532)37-68-04
Пенза (8412)22-31-16
Петрозаводск (8142)55-98-37
Псков (8112)59-10-37
Пермь (342)205-81-47

Ростов-на-Дону (863)308-18-15
Рязань (4912)46-61-64
Самара (846)206-03-16
Санкт-Петербург (812)309-46-40
Саранск (8342)22-96-24
Саратов (845)249-38-78
Севастополь (8692)22-31-93
Симферополь (3652)67-13-56
Смоленск (4812)29-41-54
Сочи (862)225-72-31
Ставрополь (8652)20-65-13
Сургут (3462)77-98-35
Сыктывкар (8212)25-95-17
Тамбов (4752)50-40-97
Тверь (4822)63-31-35

Тольятти (8482)63-91-07
Томск (3822)98-41-53
Тула (4872)33-79-87
Тюмень (3452)66-21-18
Улан-Удэ (3012)59-97-51
Ульяновск (8422)24-23-59
Уфа (347)229-48-12
Хабаровск (4212)92-98-04
Чебоксары (8352)28-53-07
Челябинск (351)202-03-61
Череповец (8202)49-02-64
Чита (3022)38-34-83
Якутск (4112)23-90-97
Ярославль (4852)69-52-93

Россия +7(495)268-04-70

Казахстан +7(727)345-47-04

Беларусь +(375)257-127-884

Узбекистан +998(71)205-18-59

Киргизия +996(312)96-26-47

<https://mpfiltri.nt-rt.ru> || mqt@nt-rt.ru

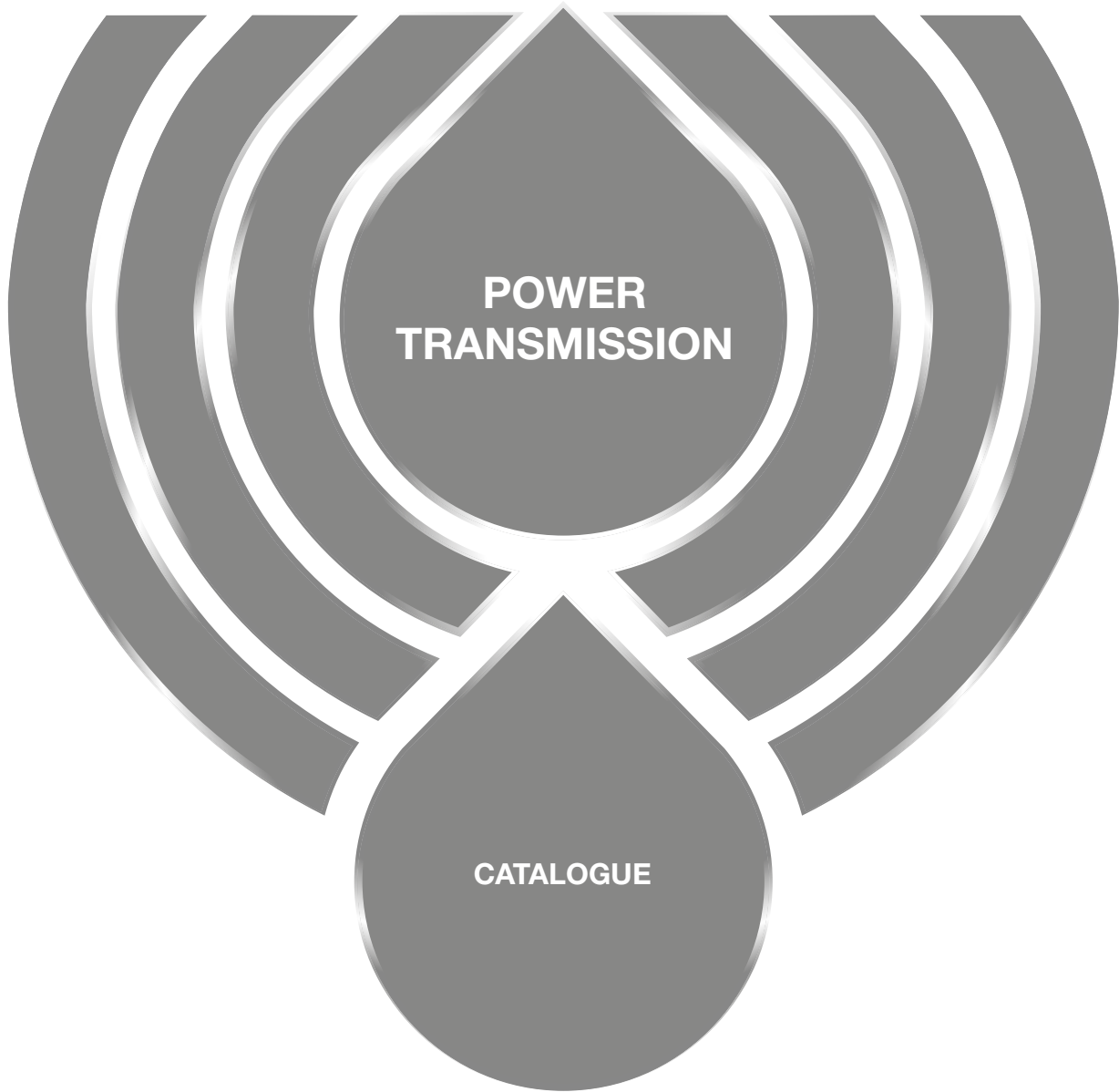

PASSION TO PERFORM



A WORLDWIDE LEADER IN THE FIELD
OF HYDRAULIC FILTRATION EQUIPMENT.

Our company started life in 1964, when Bruno Pasotto decided to attempt to cater for the requests of a market still to be fully explored, with the study, design, development, production and marketing of a vast range of filters for hydraulic equipment, capable of satisfying the needs of manufacturers in all sectors. The quality of our products, our extreme competitiveness compared with major international producers and our constant activities of research, design and development has made us a worldwide leader in the field of hydraulic circuit filtering. Present for over 50 years in the market, we have played a truly decisive role in defining our sector, and by now we are a group capable of controlling our entire chain of production, monitoring all manufacturing processes to guarantee superior quality standards and to provide concrete solutions for the rapidly evolving needs of customers and the market.

1 page INTRODUCTION

4	COMPANY
8	PRODUCT RANGE
10	BELL-HOUSINGS & COUPLINGS SIZING
12	SELECTION SOFTWARE

14 page COUPLINGS

16	General Information	
21	SGEG - SGEA - SGES - SGEK - EGE	Flexible half-coupling in aluminium, cast iron and steel
39	AKG	IEC electric motor range from size 63 up to size 225
47	SGDR - EGR	Curved-tooth steel gear coupling
53	SGES - EGE	Components for e-PTO systems

56 page BELL-HOUSINGS

58	General Information	
63	LMG	Bell-housing with rectangular flange
75	LMC - LDC	Bell-housing for piston, screw and vane pumps
83	LMS - LDS	Bell-housing - Low Noise
91	MULTI-COMPONENTS	Bell-housing - Multi-components 2 - 3
113	LME	Range for endothermic motors from 3 to 13.5 Hp

122 page ACCESSORIES

124	ANM A	Damping rings
126	PDM A	Foot brackets
127	MPDR PDMA - MPDR	Damping rods
128	OB	Cleaning covers
133	SE10	Aluminium tanks

Our work is based on a skillful interaction between advanced technology and fine workmanship, **customizing products according to specific market requests**, focusing strongly on innovation and quality, and following every step in the manufacturing of both standard and special products, fully respecting customer expectations.

MARKET
LEADER



Our customer-oriented philosophy, which enables us to satisfy all customer requests **rapidly** and **with personalized products**, makes us a **dynamic and flexible enterprise**.

The possibility of constantly controlling and monitoring the entire production process is essential to allow us to guarantee the quality of our products.

WORLDWIDE PRESENCE

Our foreign Branches enable us to offer a diversified range of products that allow us to successfully face the aggressive challenge of international competition, and also to maintain a stable presence at a local level.

The Group boasts **9** business branches



TECHNOLOGY

Our constant **quest for excellence in quality and technological innovation** allows us to offer only the best solutions and services for applications in many fields, including general industry, test rigs, lubrication, heavy engineering, renewable energies, naval engineering, offshore engineering, aviation systems, emerging technologies and mobile plant (i.e. tractors, excavators, concrete pumps, platforms).



AND PRODUCTION

Our high level of technological expertise means **we can rely entirely on our own resources, without resorting to external providers.** This in turn enables us to satisfy a growing number of customer requests, also exploiting our constantly updated range of machines and equipment, featuring **fully-automated workstations** capable of **24-hour production.**





SUCTION FILTERS

- Mounting:
- Tank immersed
 - In-Line
 - In tank with shut off valve
 - In tank with flooded suction



RETURN FILTERS

- Mounting:
- In-Line
 - Tank top
 - In single and duplex designs



RETURN / SUCTION FILTERS

- Mounting:
- In-Line
 - Tank top



SPIN-ON FILTERS

- Mounting:
- In-Line
 - Tank top



LOW & MEDIUM PRESSURE FILTERS

- Mounting:
- In-Line
 - Parallel manifold version
 - In single and duplex designs



HIGH PRESSURE FILTERS

- Mounting:
- In-Line
 - Manifold
 - In single and duplex designs

PRODUCT RANGE

MP Filtri can offer a vast and articulated range of products for the global market, suitable for all industrial sectors using hydraulic equipment.

This includes filters (suction, return, return/suction, spin-on, pressure, stainless steel pressure, ATEX filters) and structural components (motor/pump bell-housings, transmission couplings, damping rings, foot brackets, aluminium tanks, cleaning covers).

We can provide all the skills and solutions required by the modern hydraulics industry to monitor contamination levels and other fluid conditions.

Mobile filtration units and a full range of accessories allow us to supply everything necessary for a complete service in the hydraulic circuits.



STAINLESS STEEL HIGH PRESSURE FILTERS

- Mounting:
- In-Line
 - Manifold
 - In single and duplex designs



FILTERS FOR POTENTIALLY EXPLOSIVE ATMOSPHERE

- Mounting:
- In-Line



CONTAMINATION CONTROL SOLUTIONS

- Off-line, in-line particle analyser
- Off-line bottle sampling products
- Fully calibrated using relevant ISO standards
- A wide range of variants to support fluid types and communication protocols
- Mobile Filtration Units with flow rates from 15 l/min up to 200 l/min



POWER TRANSMISSION PRODUCTS

- Aluminium bell-housings for motors from 0.12 kW to 400 kW
- Couplings in Aluminium Cast Iron - Steel
- Damping rings
- Foot bracket
- Aluminium tanks
- Cleaning covers



TANK ACCESSORIES

- Oil filler and air breather plugs
- Optical and electrical level gauges
- Pressure gauge valve selectors
- Pipe fixing brackets
- Pressure gauges

Bell-housings & Couplings sizing

	p.
AUTOMATIC	11
MANUALLY	12

SOFTWARE FOR AUTOMATIC CALCULATION

The web-based software program will allow you to select the most suitable MP Filtri's Filters, in accordance with your process design requirements.

The program will automatically check your input design process prior to propose you the acceptable solutions and create an output in PDF report style format.

The MP Filtri Selection Tool software program is easy to use with a flexible fast design method and provides improved layout formats with full descriptions.

The related, complete user guide is available as Manual and downloadable from the "Download" section of MP Filtri website, as well as scanning the following QR code



**BELL-HOUSINGS
& COUPLINGS**





BELL-HOUSINGS & COUPLINGS SIZING

A GUIDE TO SELECT THE CORRECT BELL-HOUSING AND DRIVE COUPLING MANUALLY

DATA REQUIRED

- Electric motor power/motor size
- Manufacturer and pump type

TO VERIFY:

- 1 - Pump and motor shaft dimensions (see electric motor data sheet)
- 2 - Shaft and flange pump (see pump data sheet)

Example:

- Electric motor 2.2 kW - size 100-112
- Atos pump code PFE31 - Shaft 1

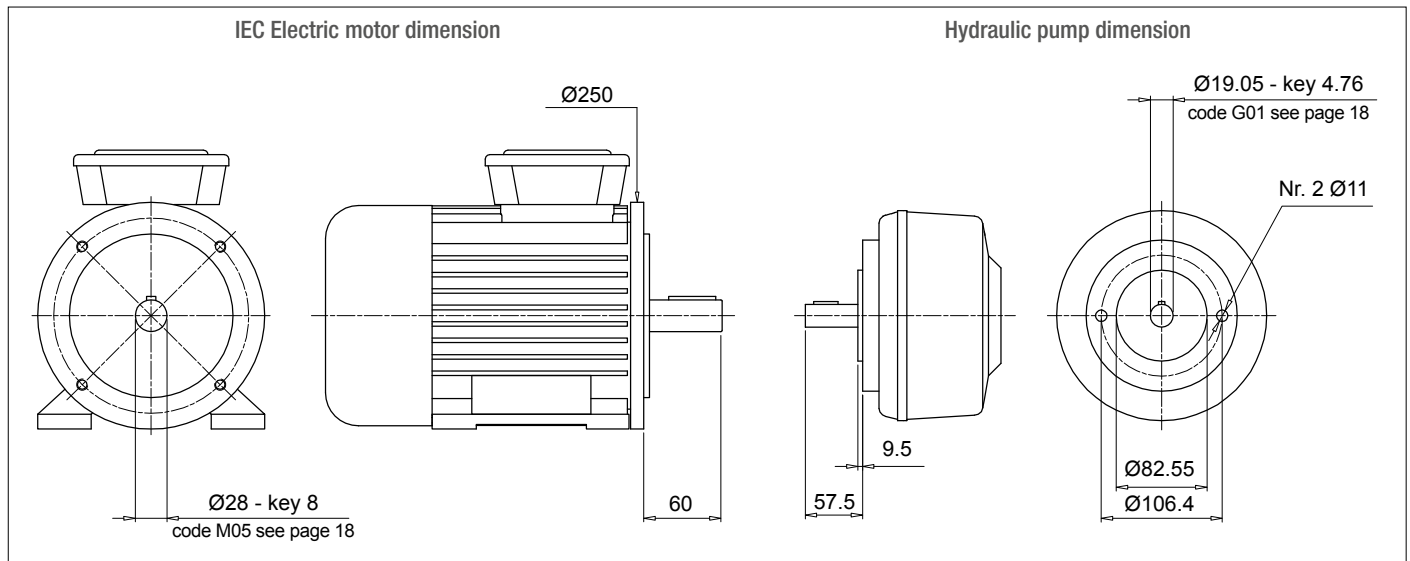

Bell-Housing's length calculation

- $H = 60 + 18 + 57.5 = 135.5$ mm (18 = Sp spider - see page 31)
- Choose type of bell-housing (LMC - LMS):
For monobloc bell-housing LMC/LDC series see pages 75 ÷ 81
For Low noise bell-housing LMS/LDS series see pages 81 ÷ 89
For Multi-components 2-3 bell housing series see pages 91 ÷ 111

Note:

The length of bell-housing must be \geq than the length calculated (135.5 mm)

Case A

Solution with monobloc bell-housing series **LMC/LDC**

Pages 75 ÷ 81 for IEC Electric motor size 100-112 - LMC250

LMC 250 bell-housing with height ≥ 135.5 - LMC250AFSQ

The bell-housing code must be completed with pump drilling code (see pages 60-61).

For the specific case:

Spigot hole 82.55 - PCD 106.4 - Nr.2 holes M10 : Drilling code 060

Definitive bell-housing code **LMC250AFSQ060**

Case B

Solution with low noise bell-housing series **LMS/LDS**

Pages 83 ÷ 89 for IEC Electric motor size 100-112 - LMS250

LMS 250 bell-housing with height ≥ 135.5 - LMS250AFSA

The bell-housing code must be completed with pump drilling code (see pages 60-61).

For the specific case:

Spigot hole 82.55 - PCD 106.4 - Nr.2 holes M10 : Drilling code 060

Definitive bell-housing code **LMS250AFSA060**

Coupling selection

Motor half-coupling (see page 26)

For IEC Electric motor size 100/112, the half-coupling is **SGEA21M05060**

Spider (see page 31)

For SGEA21, EGE2 - EGE2RR

(choose spider material on the base of the application, oil, temperature and cycle machine, etc.)

Pump half-coupling

Choose the drilling code - see pages 18-19 for shaft 19.05 - key 4.76 - code: **G01**

Pump half-coupling length = BH length - THK Spider - THK Spigot

$$\text{LMC} = 138 \text{ mm} - 60 - 18 - 9.5 = 50.5 \text{ mm}$$

$$\text{LMS} = 148 \text{ mm} - 60 - 18 - 9.5 = 60.5 \text{ mm}$$

LMC - Choose the half-coupling's length at page 26 \leq 50.5 mm.

LMS - Choose the half-coupling's length at page 26 \leq 60.5 mm.

LMC - Available length for SGEA21 = 50 mm

LMS - Available length for SGEA21 = 60 mm

Half coupling for LMC: **SGEA21G01050**

Half coupling for LMS: **SGEA21G01050**

Note: for multi pumps we recommend to use a specific support on the base of the pump's dimensions and weight.

Drive couplings provide the means by which power is transmitted from the electric motor to the hydraulic pump.

By virtue of their flexible structure, they are able to compensate angular and radial misalignments between motor and pump, and appreciably attenuate the noise generated through the drive line.

The couplings illustrated are available in aluminium and cast iron versions, with a variety of spider options, and will cover a range of applications using electric motors from size 63, rated 0.15 kW, up to size 400 rated 400 kW.

**Grub screw on all half-couplings.
Cast iron half-coupling SGE^G available with screw mounted.
Steel half-couplings SGE^S and SGE^D available with screw.**



Standard ATEX Directive 2014/34/EU and UK Regulation S.I. 2016 No. 1107 (as amended)

Half-couplings are available to use in hazardous area.

The couplings are certified according to Standard ATEX Directive 2014/34/EU and UK Regulation S.I. 2016 No. 1107 (as amended) - Category certified 2G - Area 1 and 2.

The half-couplings SGE^{*} series are in conformity to normative DIN 740/2.
The max torque to transmit is always less than the max torque that the coupling can transmit.**



GENERAL INFORMATION	page 16
SGEG - SGEA - SGES - SGEK - EGE	21
AKG	39
SGDR - EGR	47
COMPONENTS FOR e-PTO SYSTEMS	53

The half-couplings series SGE*** allow secure transmission between the electric motor and the driven side; they are able to absorb shocks and vibration, in addition to compensating radial misalignment, angular and axial.

The complete range of couplings are extrapolated from the on-line software, with a length equal than the shaft on which must be mounted and they are completed with grub screw for fixing located on the key.

The assembly of the couplings can be horizontal/vertical, withstanding vibration and load reversals.

Available for cylindrical shaft with metric and imperial dimensions as well for splined shafts as per specification DIN, ISO and SAE.

Admissible misalignment radial, angular and axial

Max admissible radial misalignment

Half-coupling	R [mm]
SGE * 01	0.5
SGE * 21	1.0
SGE * 31	1.0
SGE * 40	1.0
SGE * 51	1.5
SGE * 60	1.5
SGE * 80	2.0
SGE * 90	2.0

Max admissible angular misalignment

Half-coupling	β [°]
SGE * 01	1.5°
SGE * 21	
SGE * 31	
SGE * 40	
SGE * 51	
SGE * 60	
SGE * 80	
SGE * 90	

Max admissible angular alignment

Half-coupling	A [mm]
SGE * 01	2.0
SGE * 21	2.5
SGE * 31	3.0
SGE * 40	3.5
SGE * 51	3.5
SGE * 60	3.5
SGE * 80	4.0
SGE * 90	5.0

Standard ATEX Directive 2014/34/EU and UK Regulation S.I. 2016 No. 1107 (as amended)



Half-couplings are available to use in hazardous area.

The couplings are certified according to Standard ATEX Directive 2014/34/EU and UK Regulation S.I. 2016 No. 1107 (as amended) - Category certified 2G - Area 1 and 2.

MP Filtri couplings are developed with:

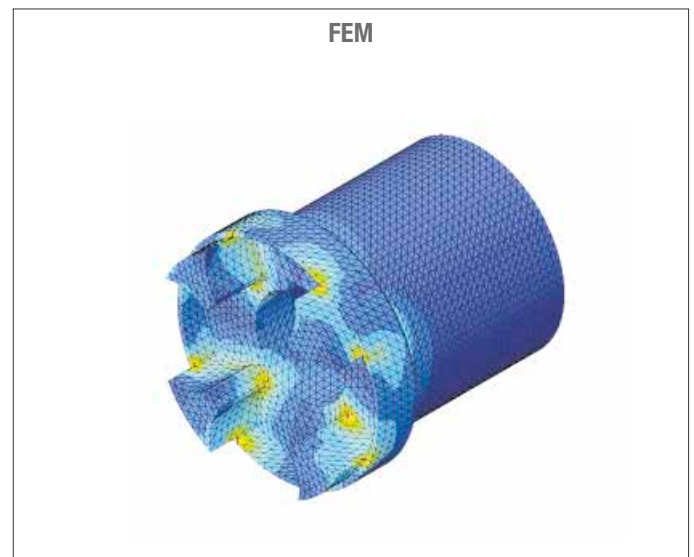

Examples verification of the coupling

Torque transmitted by electric motor:

Mt: $9560 \times \text{kW} / \text{rpm} = \text{Nm}$

Me > $Mt \times S = \text{Nm}$

Where:

Mt: Torque transmitted by electric motor

Me: Torque transmitted by coupling

kW: Power of electric motor

Rpm: Revolutions per minute of electric motor

S: Service factor

Table 1

Small pumps, uniform load, low operating pressures e.g. rotary action machine tools - 5/8 work cycles per hour	1.3
Small pumps, uniform load, high working pressures e.g. lifting equipment - 120-150 work cycles per hour	1.5
Pumps, non-uniform load e.g. lifting equipment - 280-300 work cycles per hour	1.7

Example

Electric motor, 4 pole - 4 kW
hydraulic pump, uniform load, low operating pressure

Mt: $9560 \times 4 / 1500 = 25.45 \text{ Nm}$

Me > $25.49 \times 1.3 = 33 \text{ Nm}$

Half-coupling SGEA21 meets the above requirement.

Select the half-coupling of the calculated size from the motor half-couplings table.

Note: When selecting the coupling, remember that for pumps with splined shaft, only cast iron couplings of the SGEG series can be used.

Determine the size of the coupling according to the type of installation and application envisaged, on the basis of the formulas and the following tables:

Table 2

Half-coupling type	External diameter [mm]	Nominal torque Me - Nm	Maximum transmissible torque Me - Nm	
ROTAFIT				
SGEA01	SGEK01	44	10	20
SGEA21	SGEK21	70	95	190
SGEA31	SGEK31	85	190	380
SGEA51	SGEK51	109.5	310	620
ALUMINIUM				
SGEG01		40	10	20
SGEG30		80	190	380
SGEG40	SGEK40	95	310	620
SGEG60	SGEK60	120	430	860
SGEG80	SGEK80	160	1250	2500
SGEG90		200	5500	6100
CAST IRON				
SGES40		95	310	620
SGES60		120	430	860
SGES80		180	1250	2500
STEEL				

Nominal and maximum torque values are referred to couplings assembled with standard flexible spiders of the **EGE**** series (see page 31).

Where higher torques are to be transmitted, use flexible spiders of the **EGE**RR** series (see page 31).

Parallel shaft - Metric Dimensions

Ø [mm]	key [mm]	Code
12	4	C00
15	5	C01
16	4	C02
16	5	C03
17	5	C04
18	6	C05
20	5	C06
19	5	C07
30	10	C08
20	6	C09
16	5	C10
15	4	C11
22	6	D00
24	6	D01
25	8	D02
30	8	D03
32	10	D04
35	10	D05
40	12	D06
45	14	D07
50	14	D08
70	20	D09
22	8	D10
52	16	D20
8	3	E00
10	3	E01
22	5	E02
32	8	E03
35	8	E04
82	22	E05
25	7	E06
63	18	E07
9	3	M00
11	4	M01
14	5	M02
19	6	M03
24	8	M04
28	8	M05
38	10	M06
42	12	M07
48	14	M08
55	16	M09
60	18	M10
65	18	M11
75	20	M12
80	22	M13
90	25	M14
95	25	M15
100	28	M16
110	28	M17
85	22	M18

Parallel shaft - Imperial Dimensions

Ø		key		Code
[inch]	[mm]	[inch]	[mm]	
7/16"	11.11	1/8"	3.18	G00
3/4"	19.05	3/16"	4.76	G01
7/8"	22.22	3/16"	4.76	G02
7/8"	22.22	1/4"	6.35	G03
1"	25.4	3/16"	4.76	G04
1"	25.40	1/4"	6.35	G05
1 1/4"	31.75	1/4"	6.35	G06
1 1/4"	31.75	5/16"	7.94	G07
1 3/8"	34.94	5/16"	7.94	G08
1 1/2"	38.1	3/8"	9.52	G09
1 5/8"	41.27	3/8"	9.52	H00
1 3/4"	44.45	7/16"	11.11	H01
2"	50.8	1/2"	12.7	H02
2 11/32"	53.94	1/2"	12.7	H03
3/4"	19.02	1/8"	3.17	H04
1"	25.4	3/16"	4.76	H05
5/8"	15.87	3/16"	4.76	H06
17/32"	13.45	1/8"	3.18	H07
11/16"	17.46	3/16"	4.76	H08
1/2"	12.7	1/8"	3.18	H09
5/8"	15.87	5/32"	3.97	L00
7/8"	22.22	5/32"	4	L01
11/8"	28.58	1/4"	6.35	L02
3/4"	19.05	1/4"	6.35	L03
1 7/8"	47.63	1/2"	12.7	L04
3 3/8"	85.73	7/8"	22.23	L05
2 3/8"	60.33	5/8"	15.88	L06
2 3/8"	60.33	1/2"	12.7	L07
2 7/8"	73.03	3/4"	19.05	L08
3 5/8"	92.07	7/8"	22.22	L09
1 5/8"	41.6	15/32"	12	L10
1 1/8"	28.58	5/16"	7.94	L15

Parallel shaft - Double Key

Ø [mm]	key [mm]	Code
16.00	4.00	C02***2H
	5.00	
20.00	5.00	C06***2M
	6.00	
19.00	5.00	C07***2L
	6.00	
24.00	6.00	D01***2N
	8.00	
30.00	8.00	D03***2P
	10.00	
22.22	4.76	G02***2E
	6.35	
25.40	6.35	G04***2F
	4.76	
31.75	6.35	G06***2G
	7.94	

*** = coupling length

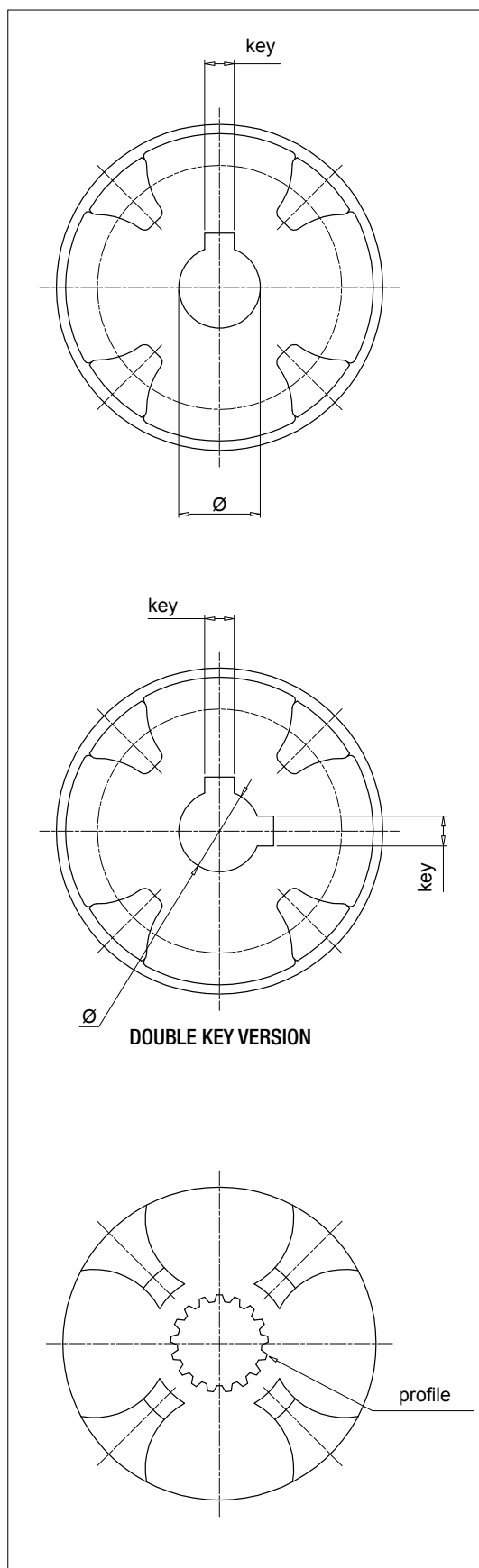

SAE Bore - ANS.B.92.1-1970

Profile	Nr. of Th	Code
17 th 8/16	17	PD01
14 th 12/24	14	PD02
16 th 12/24	16	PD03
17 th 12/24	17	PD04
9 th 16/32	9	PD05
11 th 16/32	11	PD06
12 th 16/32	12	PD07
13 th 16/32	13	PD08
15 th 16/32	15	PD09
21 th 16/32	21	PD10
23 th 16/32	23	PD11
27 th 16/32	27	PD12
40 th 16/32	40	PD13
20 th 24/48	20	PD14
21 th 24/48	21	PD15
23 th 24/48	23	PD16
25 th 24/48	25	PD17
26 th 24/48	26	PD18
27 th 12/48	27	PD19
28 th 24/48	28	PD20
29 th 24/48	29	PD21
32 th 24/48	32	PD22
21 th 32/64	21	PD23
30 th 32/64	30	PD24
33 th 32/64	33	PD25
23 th 40/80	23	PD26
36 th 48/96	36	PD27
41 th 48/96	41	PD28
47 th 48/96	47	PD29
13 th 8/16	13	PD30
15 th 8/16	15	PD31
14 th 16/32	14	PD32
40 th 16/32	40	PD33
33 th 16/32	33	PD34
9 th 20/40	9	PD35
10 th 16/32	10	PD36
25 th 20/40	25	PD37

Splined bore as per standard DIN5480

Profile	Nr. of Th	Code
W18 x 1.25 x 13	13	PA01
W20 x 1.25 x 14	14	PA02
W25 x 1.25 x 18	18	PA03
W28 x 1.25 x 21	21	PA04
W32 x 1.25 x 24	24	PA05
W38 x 1.25 x 29	29	PA06
W30 x 2 x 14	14	PA07
W32 x 2 x 14	14	PA08
W35 x 2 x 16	16	PA09
W37 x 2 x 17	17	PA10
W38 x 2 x 18	18	PA11
W40 x 2 x 18	18	PA12
W42 x 2 x 20	20	PA13
W45 x 2 x 21	21	PA14
W50 x 2 x 24	24	PA15
W55 x 2 x 26	26	PA16
W60 x 2 x 28	28	PA17
W70 x 2 x 34	34	PA18
W80 x 2 x 38	38	PA19
W60 x 3 x 18	18	PA20
W70 x 3 x 22	22	PA21
W75 x 3 x 24	24	PA22
W90 x 3 x 28	28	PA23
W105 x 3 x 34	34	PA24
W80 x 3 x 25	25	PA25
W50 x 1.25 x 38	38	PA26
W62 x 1.25 x 48	48	PA27
W40 x 1.5 x 25	25	PA28
W32 x 1.5 x 20	20	PA29
W40 x 1.25 x 30	30	PA30

Splined bore as per standard DIN5481

Profile	Nr. of Th	Code
8 x 10	28	PC01
10 x 12	30	PC02
12 x 14	31	PC03
15 x 17	32	PC04
17 x 20	33	PC05
21 x 24	34	PC06
26 x 30	35	PC07
30 x 34	36	PC08
60 x 65	41	PC09

Splined bore as per standard DIN5482

Profile	Nr. of Th	Code
A15 x 12	8	PB01
A17 x 14	9	PB02
A18 x 15	10	PB03
A20 x 17	12	PB04
A22 x 19	13	PB05
A25 x 22	14	PB06
A28 x 25	15	PB07
A30 x 27	16	PB08
A32 x 28	17	PB09
A35 x 31	18	PB10
A38 x 34	19	PB11
A40 x 36	20	PB12
A42 x 38	21	PB13
A45 x 41	22	PB14
A48 x 44	23	PB15
A50 x 45	24	PB16
A52 x 47	25	PB17
A55 x 50	26	PB18
A58 x 53	27	PB19
A60 x 55	28	PB20
A62 x 57	29	PB21
A65 x 60	30	PB22
A68 x 62	31	PB23
A70 x 64	32	PB24
A72 x 66	33	PB25
A75 x 69	34	PB26
A78 x 72	35	PB27
A80 x 74	36	PB28
A82 x 76	37	PB29
A85 x 79	38	PB30
A88 x 82	39	PB31
A90 x 84	40	PB32
A92 x 86	41	PB33
A95 x 89	42	PB34
A98 x 92	43	PB35
A100 x 94	44	PB36

SGEG - SGEA - SGES - SGEK - EGE series

Flexible half-coupling in aluminium, cast iron and steel



Technical data

Couplings - Flexible half-coupling in aluminium, cast iron and steel

Half-couplings materials

SGEA: Pressure die cast aluminium
 SGEG: Cast Iron en-GJL-250 (gg25)
 SGES: Steel C40
 SGEK: Pressure die cast aluminium
 SGEK: Cast Iron en-GJL-250 (gg25)



Spider materials

EGE** series: Oil-resistant NBR 85 Shore A - black colour
 EGE**RR series: in polyurethane Laripur - 92 Shore A - LPR202-95A - red colour

Compatibility with fluids

- Mineral oils types HH-HL-HM-HR-HV, to ISO 6743/4 standard
- Water based emulsions types HFAE-HFAS, to ISO 6743/4 standard
- Water glycol type HFC, to ISO 6743/4 standard: ask for anodized version

Special Applications

Any applications not covered by the normal indications contained in this catalogue must be evaluated and approved by MP Filtri Technical and Sales Department

Temperature

Spider oil-resistant rubber: from -20 °C to +90 °C
 Spider polyurethane resin: from -30 °C to +120 °C

Note

For temperatures outside this range, contact MP Filtri Technical and Sales Department



Range

IEC Electric Motors size	Aluminium		G25 UNI 5007 Cast Iron - C40 Carbon Steel			
	Shaft ISO 3019-2	Shaft ISO 3019-2	Shaft ANSI B92. 1A 1976	Shaft DIN 5480	Shaft DIN 5481	Shaft DIN 5482
IEC 80 Ø200 - Ø19x40	●	●	●	●	●	●
IEC 90 Ø200 - Ø24x50	●	●	●	●	●	●
IEC 100 Ø250 - Ø28x60	●	●	●	●	●	●
IEC 112 Ø250 - Ø28x60	●	●	●	●	●	●
IEC 132 Ø300 - Ø38x80	●	●	●	●	●	●
IEC 160 Ø350 - Ø42x110	●	●	●	●	●	●
IEC 180 Ø350 - Ø48x110	●	●	●	●	●	●
IEC 200 Ø400 - Ø55x110	●	●	●	●	●	●
IEC 225 Ø450 - Ø60x140		●	●	●	●	●
IEC 250 Ø550 - Ø65x140		●	●	●	●	●
IEC 280 Ø550 - Ø75x140		●	●	●	●	●
IEC 315 Ø660 - Ø80x170		●	●	●	●	●
IEC 355 Ø800 - Ø90x170		●	●	●	●	●

IEC Electric Motors size	European standard size						German standard size		
	0.5	1	2	3	3.5	4	ZB	ZF	ZG
IEC 63 Ø140 - Ø11x23	●	●	●				●		
IEC 71 Ø160 - Ø14x30	●	●	●				●		
IEC 80 Ø200 - Ø19x40	●	●	●	●			●	●	
IEC 90 Ø200 - Ø24x50	●	●	●	●			●	●	
IEC 110 Ø250 - Ø28x60		●	●	●	●		●	●	
IEC 112 Ø250 - Ø28x60		●	●	●	●		●	●	
IEC 132 Ø300 - Ø38x80		●	●	●	●	●		●	●
IEC 160 Ø350 - Ø42x110			●	●	●	●		●	●
IEC 180 Ø350 - Ø48x110			●	●	●	●		●	●
IEC 200 Ø400 - Ø55x110			●	●	●	●		●	●
IEC 225 Ø450 - Ø60x140				●	●	●			●

Couplings for standard IEC motors, protection class IP 54 / IP 55

A. C. motor 50 Hz			Motor output n=3000 RPM 2 poles		Coupling size	Motor output n=1500 RPM 4 poles		Coupling size	Motor output n=1000 RPM 6 poles		Coupling size	Motor output n=750 RPM 8 poles		Coupling size
Size	Shaft end Ø x L [mm]		Output P [kW]	Torque T [Nm]		Output P [kW]	Torque T [Nm]		Output P [kW]	Torque T [Nm]		Output P [kW]	Torque T [Nm]	
	2-pole	4, 6, 8 pole												
56	9 x 20		0.09	0.32		0.06	0.43		0.037	0.43				
			0.12	0.41		0.09	0.64		0.045	0.52				
63	11 x 23		0.18	0.62	01	0.12	0.88	01	0.06	0.7	01			01
			0.25	0.86		0.18	1.3		0.09	1.1				
71	14 x 30		0.37	1.3		0.25	1.8		0.18	2		0.09	1.4	
			0.55	1.9		0.37	2.5		0.25	2.8		0.12	1.8	
80	19 x 40		0.75	2.5		0.55	3.7		0.37	3.9		0.18	2.5	
			1.1	3.7		0.75	5.1		0.55	5.8		0.25	3.5	
90S	24 x 50		1.5	5	21	1.1	7.5	21	0.75	8	21	0.37	5.3	21
90L			2.2	7.4		1.5	10		1.1	12		0.55	7.9	
100L	28 x 60		3	9.8		2.2	15		1.5	15		0.75	11	
			3	20		1.5	15		1.1	16				
112M			4	13		4	27		2.2	22		1.5	21	
132S	38 x 80		5.5	18		5.5	36		3	30		2.2	30	
			7.5	25		7.5	49		4	40		3	40	
132M									5.5	55				
160M	42 x 110		11	36		11	72		7.5	75		4	54	
			15	49		15	98		11	109		5.5	74	
160L			18.5	60	40/51	15	98	40/51	11	109	40/51	7.5	100	40/51
180M	48 x 110		22	71		18.5	121							
180L			22	144		15	148		11	145				
200L	55 x 110		30	97		30	196		18.5	181		15	198	
			37	120		22	215		15	198				
200S	55 x 110	60 x 140			60	37	240	60			60	18.5	244	60
225M			45	145		45	292		30	293		22	290	
250M	60 x 140	65 x 140	55	177		55	356		37	361		30	392	
280S		75 x 140	75	241		75	484		45	438		37	483	
280M			90	289		90	581		55	535		45	587	
315S			110	353		110	707		75	727		55	712	
315M	65 x 140	80 x 170	132	423	80	132	849	80	90	873	80	75	971	80
			160	513		160	1030		110	1070		90	1170	
315L			200	641		200	1290		132	1280		110	1420	
			160	1550		132	1710							
315	85 x 170		250	802		250	1600		200	1930		160	2070	
			315	1010		315	2020		250	2410		200	2580	
355	75 x 140		355	1140		355	2280							
			400	1280		400	2570		315	3040		250	3220	
400	80 x 170		500	1600	90	500	3210	90	400	3850	90	315	4060	90
			560	1790		560	3580		450	4330		355	4570	
			630	2020		630	4030		500	4810		400	5150	
			710	2270		710	4540		560	5390		450	5790	
			800	2560		800	5120		630	6060		500	6420	

SGEG-SGEA-SGES-SGEK

Designation & Ordering code

PUMP HALF-COUPLING FOR PARALLEL SHAFT

Pump half-coupling	Configuration example: SGE A 21 G02 050 2E					
SGE						
Series and material						
A	Aluminium					
G	Cast Iron					
S	Steel					
K	Aluminium / Cast Iron - Reduced length 					
Size	SGEG	SGEA	SGES	SGEK		
	01	01	01	01		
	30	21	30	21		
	40	31	40	31		
	60	51	60	51		
	80		80	40		
	90		90	60		
				80		
Pump shaft code						
G02	See page 18					
Length						
050	See pages 26 ÷ 30					
Double key way (available combinations only)						
2E	See page 18 (parallel shaft - double key)					

PUMP HALF-COUPLING FOR SPLINED SHAFT

Pump half-coupling	Configuration example: SGE G 40 PD02 050				
SGE					
Series and material					
G	Cast Iron				
S	Steel				
K	Cast Iron - Reduced length 				
Size	SGEG	SGES	SGEK		
	01	01	01		
	30	30	21		
	40	40	31		
	60	60	51		
	80	80	40		
	90	90	60		
			80		
Pump shaft code					
PD02	See pages 19				
Length					
050	See pages 28 ÷ 30				

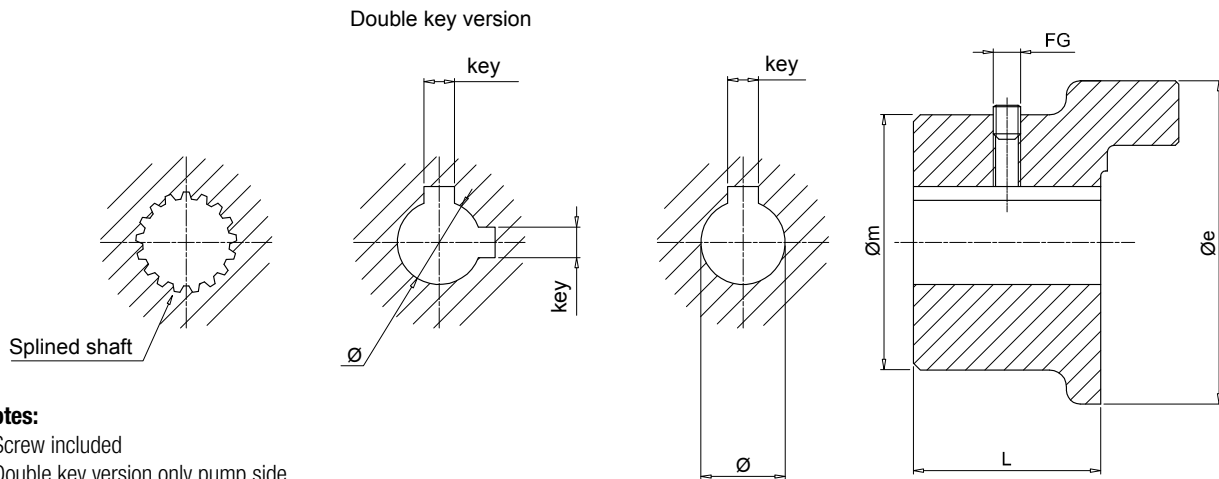

Notes:

- Screw included
- Double key version only pump side

Motor half-coupling

IEC - Electric motors		Half-coupling code	Dimensions [mm]							Weight [kg]
Motor size	Shaft end [Ø x L]		Øe	Øm	L	Ø	key	FG		
63	11x23	SGEG01M01021	40	50	21	11	4	M6	0.32	
71	14x30	SGEG01M02028	40	50	28	14	5	M6	0.42	
80	19x40	SGEG01M03040	40	50	40	19	6	M6	0.61	
90	24x50	SGEG01M04050	40	50	50	24	8	M6	0.77	
100 - 112	28x60	SGEG30M05060	80	65	60	28	8	M8	2.35	
		SGEG40M05060	95	75	60	28	8	M8	2.65	
132	38x80	SGEG30M06080	80	65	80	38	10	M8	3.15	
		SGEG40M06080	95	75	80	38	10	M8	3.55	
160	42x110	SGEG40M07110	95	75	110	42	12	M8	4.70	
180	48x110	SGEG40M08110	95	95	110	48	14	M8	4.55	
200	55x110	SGEG40M09110	95	95	110	55	16	M8	4.35	
		SGEG60M09110	120	98	110	55	16	M8	9.00	
225	60x140	SGEG60M10140	120	118	140	60	18	M8	12.30	
		SGEG60M11140	120	118	140	65	18	M8	12.00	
250	65x140	SGEG80M11140	160	138	140	65	18	M8	18.30	
		SGEG80M12140	160	138	140	75	20	M10	17.70	
280	75x140	SGEG90M12100	200	160	100	75	20	M10	21.00	
		SGEG80M13170	160	138	170	80	22	M10	20.60	
315	80x170	SGEG90M13100	200	160	100	80	22	M10	20.00	
		SGEG90M15100	200	160	100	95	25	M10	19.00	
400	100x210	SGEG90M16100	200	160	100	100	28	M10	18.00	

Pump half-couplings

Half-coupling code	Dimensions [mm]					Standard lengths [mm]
	Ø min	Ø max	Øe	L min	L max	
SGEG01 *** **	-	24	40	20	50	every 5 mm
SGEG30 *** **	-	42	80	30	80	
SGEG40 *** **	-	55	95	30	110	
SGEG60 *** **	-	75	120	40	140	
SGEG80 *** **	-	85	160	50	170	
SGEG90 *** **	-	100	200	40	100	

Complete the half-coupling code with the shaft's code and length

Example: **SGEG40PD02040**

PD02 - see page 19

040 - table "pump half-coupling - standard lengths"

All SGEG series half-couplings are supplied with a grub screw hole as standard, and with a grub screw **UNI 5929 DIN 916** fitted to the hub.

Note: For lengths other than those indicated in "Pump half-coupling" table, contact MP Filtri Technical and Sales Department.

Dimensions

Double key version

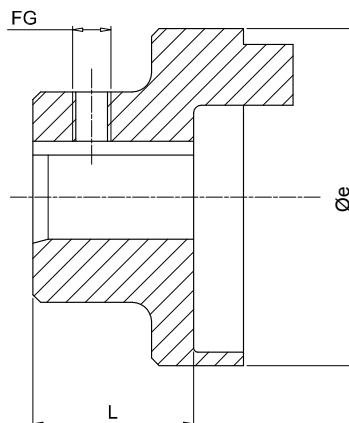
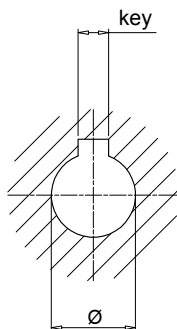
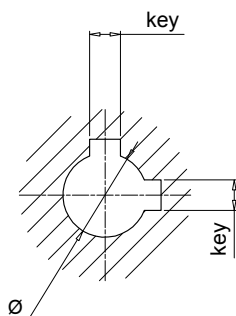

Notes:

- Screw not included
- Double key version pump side only

Motor half-coupling

IEC - Electric motors Motor size	Shaft end [Ø x L]	Half-coupling code	Øe	Dimensions [mm]				Weight [kg]
				L	Ø	key	FG	
63	11x23	SGEA01M01019	44.0	21	11	4	M5	0.07
71	14x30	SGEA01M02028	44.0	28	14	5	M5	0.08
80	19x40	SGEA01M03040	44.0	40	19	6	M5	0.12
		SGEA21M03040	70.0	40	19	6	M6	0.30
90	24x50	SGEA01M04048	44.0	48	24	8	M5	0.13
		SGEA21M04048	70.0	48	24	8	M6	0.28
100 - 112	28x60	SGEA21M05060	70.0	60	28	8	M6	0.33
		SGEA31M05060	85.0	60	28	8	M8	0.48
		SGEA21M06080	70.0	80	38	10	M6	0.44
132	38x80	SGEA31M06077	85.0	77	38	10	M8	0.78
		SGEA51M06077	109.5	77	38	10	M8	1.60
		SGEA51M07109	109.5	109	42	12	M8	1.60
160	42x110	SGEA51M07109	109.5	109	42	12	M8	1.60
180	48x110	SGEA51M08109	109.5	109	48	14	M8	1.60
200	55x110	SGEA51M09109	109.5	109	55	16	M8	1.90

Pump half-couplings

Half-coupling code	Dimensions [mm]					Standard lengths [mm]								FG		
	Ø min	Ø max	Øe	L min	L max	17	23	30	40	44	48	-	-		-	-
SGEA01 *** **	11	19	44.0	17	50	17	23	30	40	44	48	-	-	-	-	M5
SGEA21 *** **	15	24	70.0	23	50	35	40	42	44	48	50	-	-	-	-	M6
SGEA21 *** **	25	28	70.0	40	60	40	42	44	48	50	55	58	60	-	-	M6
SGEA31 *** **	18	32	85.0	40	60	42	45	48	50	52	55	58	60	-	-	M8
SGEA31 *** **	38	42	85.0	60	80	60	65	70	77	80	-	-	-	-	-	M8
SGEA51 *** **	18	40	109.5	40	70	42	45	48	50	52	55	58	60	65	70	M8
SGEA51 *** **	38	55	109.5	70	109	70	75	80	85	90	95	100	105	109	-	M8

Complete the half-coupling code with the shaft's code and length

Example: **SGEA51D02040**

D02 - see page 18

040 - table "pump half-coupling - standard lengths"

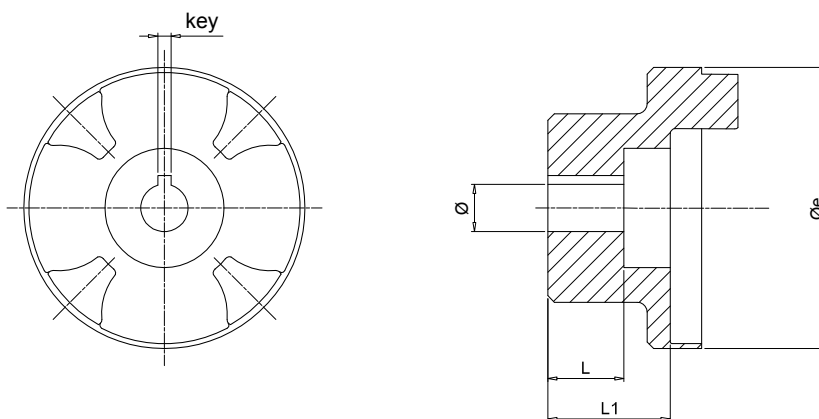

Half-coupling for gear pumps - parallel

Half-coupling code	Øe	Dimensions [mm]				key	Weight [kg]
		L	L1	Ø			
SGEA01FS05M	44	10.0	17.0	6	2	0.07	
SGEA01FS05C	44	10.0	17.0	7	2	0.08	
SGEA01FS1C0	44	-	17.0	12	3	0.13	
SGEA21FS1C0	70	14.5	21.5	12	3	0.48	
SGEA31FS1C0	85	14.5	37.0	12	3	1.90	

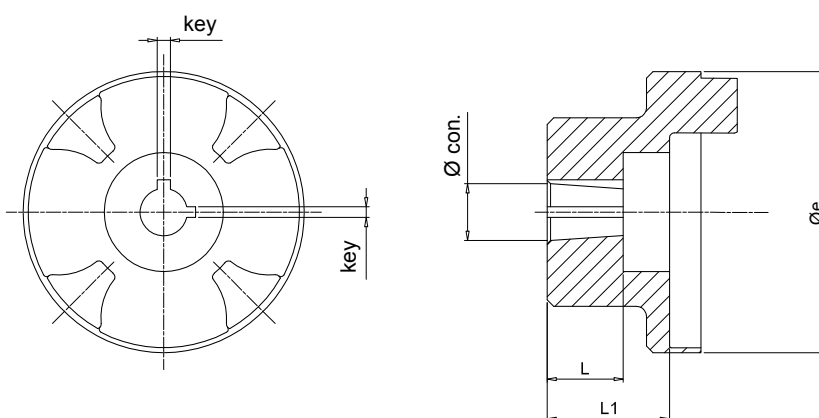

Half-coupling for gear pumps - tapered

Half-coupling code	Øe	Dimensions [mm]				key	Weight [kg]	Conical
		L	L1	Ø				
SGEA01FS100	44.0	14.5	16.0	9.7	2.4	0.12	1:8	
SGEA01FS1M0	44.0	16.0	16.0	13.9	3	0.30	1:8	
SGEA01FSZBR	44.0	11.5	14.5	9.8	2	0.28	1:5	
SGEA21FS100	70.0	14.5	21.5	9.7	2.4	0.33	1:8	
SGEA21FS1M0	70.0	18.5	21.5	13.9	3	0.78	1:8	
SGEA21FS200	70.0	21.5	21.5	17.2	3.2 - 4	1.60	1:8	
SGEA21FSZFR	70.0	20.0	21.5	16.9	3	1.60	1:5	
SGEA21FS300	70.0	27.0	41.0	21.6	4	1.60	1:8	
SGEA31FS100	85.0	14.5	37.0	9.7	2.4	1.90	1:8	
SGEA31FS1M0	85.0	17.5	36.0	13.9	3	0.33	1:8	
SGEA31FS200	85.0	23.0	37.0	17.2	3.2 - 4	0.48	1:8	
SGEA31FS300	85.0	27.0	37.0	21.6	4	0.78	1:8	
SGEA31FS350	85.0	35.0	37.0	25.6	4.76 - 5	1.60	1:8	
SGEA31FSZFR	85.0	17.0	37.0	16.9	3	1.60	1:5	
SGEA31FSZGR	85.0	27.0	34.0	25.2	5	1.60	1:5	
SGEA51FS200	109.5	23.5	32.0	17.2	3.2 - 4	1.90	1:8	
SGEA51FS300	109.5	25.0	32.0	21.6	4	1.90	1:8	
SGEA51FS350	109.5	32.0	32.0	25.6	4.76-5	1.60	1:8	
SGEA51FSZFR	109.5	19.5	32.0	16.9	3	1.90	1:5	
SGEA51FSZGR	109.5	25.0	32.0	24.6	5	1.90	1:5	

Dimensions

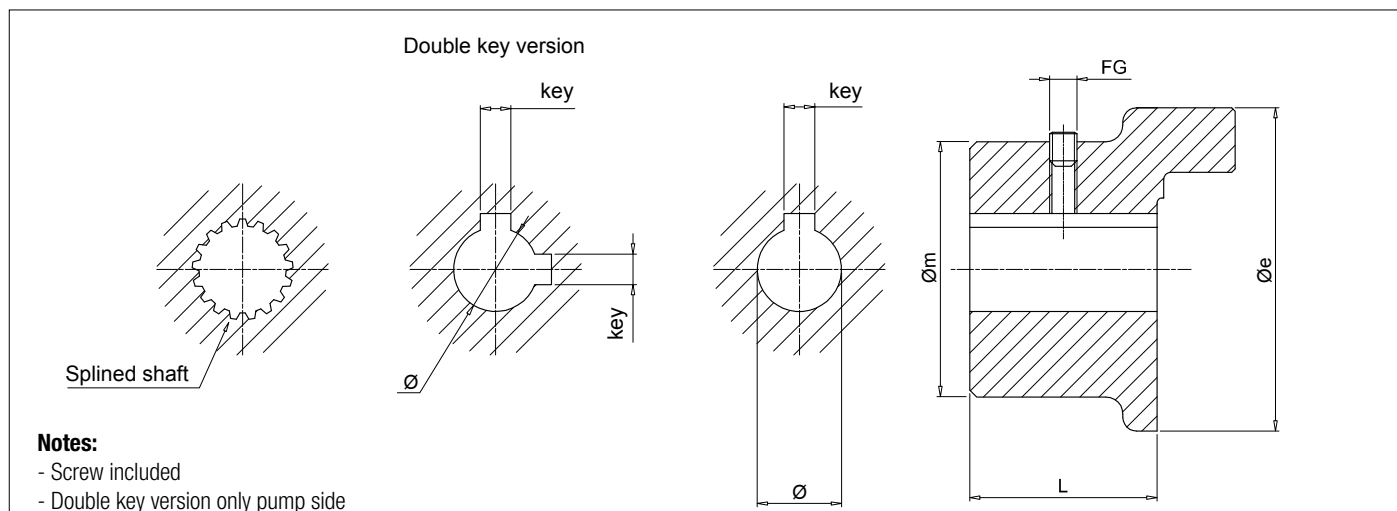

Notes:

- Screw included
- Double key version only pump side

Motor half-coupling

IEC - Electric motors		Half-coupling code	Dimensions [mm]							Weight [kg]
Motor size	Shaft end [Ø x L]		Øe	Øm	L	Ø	key	FG		
63	11x23	SGES01M01021	40	50	21	11	4	M6	0.32	
71	14x30	SGES01M02028	40	50	28	14	5	M6	0.42	
80	19x40	SGES01M03040	40	50	40	19	6	M6	0.61	
90	24x50	SGES01M04050	40	50	50	24	8	M6	0.77	
100 - 112	28x60	SGES31M05060	80	-	60	28	8	M8	2.35	
		SGES40M05060	95	-	60	28	8	M8	2.65	
132	38x80	SGES31M06080	80	-	80	38	10	M8	3.15	
		SGES40M06080	95	-	80	38	10	M8	3.55	
160	42x110	SGES40M07110	95	-	110	42	12	M8	4.70	
180	48x110	SGES40M08110	95	-	110	48	14	M8	4.55	
200	55x110	SGES40M09110	95	-	110	55	16	M8	4.35	
		SGES60M09110	120	-	110	55	16	M8	9.00	
225	60x140	SGES60M10140	120	-	140	60	18	M8	12.30	
250	65x140	SGES60M11140	120	-	140	65	18	M8	12.00	
		SGES80M11140	160	-	140	65	18	M8	18.30	
280	75x140	SGES80M12140	160	-	140	75	20	M10	17.70	
		SGES90M12100	200	-	100	75	20	M10	21.00	
315	80x170	SGES80M13170	160	-	170	80	22	M10	20.60	
		SGES90M13100	200	-	100	80	22	M10	20.00	
355	95x140	SGES90M15100	200	-	100	95	25	M10	19.00	
400	100x210	SGES90M16100	200	-	100	100	28	M10	18.00	

Pump half-couplings

Half-coupling code	Dimensions [mm]					Standard lengths [mm]
	Ø min	Ø max	Øe	L min	L max	
SGES01 *** **	-	24	40	20	50	every 5 mm
SGES30 *** **	-	42	80	30	80	
SGES40 *** **	-	55	95	30	110	
SGES60 *** **	-	75	120	40	140	
SGES80 *** **	-	85	160	50	170	
SGES90 *** **	-	100	200	40	100	

Complete the half-coupling code with the shaft's code and length

Example: **SGES40PD02040**

PD02 - see page 19

040 - table "pump half-coupling - standard lengths"

All SGES series half-couplings are supplied with a grub screw hole as standard, and with a grub screw **UNI 5929 DIN 916** fitted to the hub.

Note: For lengths other than those indicated in "Pump half-coupling" table, contact MP Filtri Technical and Sales Department.

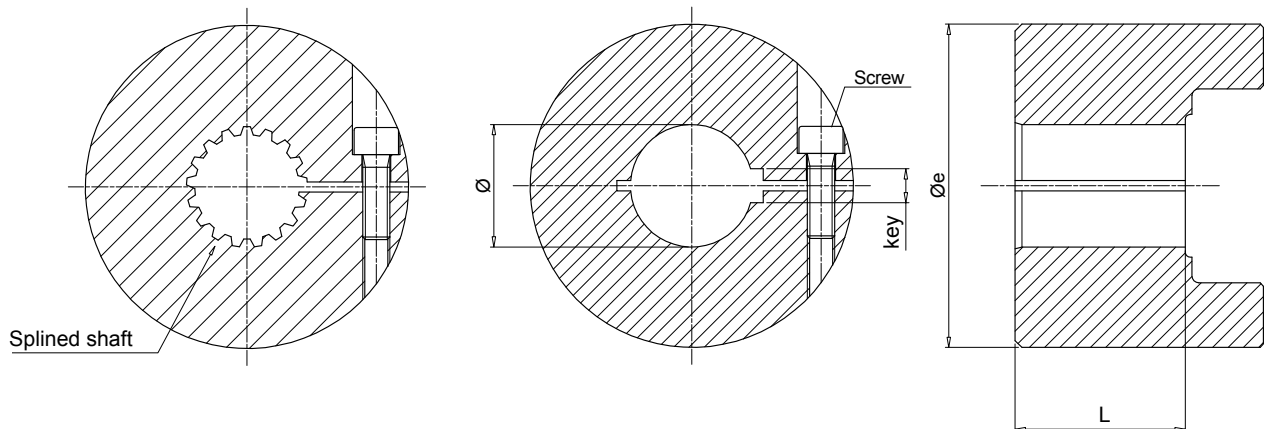

Motor half-coupling

IEC - Electric motors		Half-coupling code	Dimensions [mm]					Weight [kg]
Motor size	Shaft end [Ø x L]		Øe	L	Ø	key	Screw	
132	38x80	SGES40M06050GO	95	50	38	10	M8	4.00
160	42x110	SGES40M07065GO	95	65	42	12	M8	5.00
180	48x110	SGES40M08065GO	95	65	48	14	M8	5.00
200	55x110	SGES60M09085GO	120	85	55	16	M10	8.00
225	60x140	SGES60M10085GO	120	85	60	18	M10	8.00
250	65x140	SGES60M11085GO	120	85	65	18	M10	8.00
280	75x140	SGES60M12085GO	120	85	75	20	M10	8.00
315	80x170	SGES80M13085GO	160	85	80	22	M10	13.00

Pump half-couplings

Half-coupling code	Dimensions [mm]			
	Ø min	Ø max	Øe	L
SGES40 *** **	-	55	95	35
SGES60 *** **	-	65	120	65
SGES80 *** **	-	75	160	85

Complete the half-coupling designation with the pump interface code and the length.
 Example: **SGES40PD02035GO** (see page 19).

Dimensions

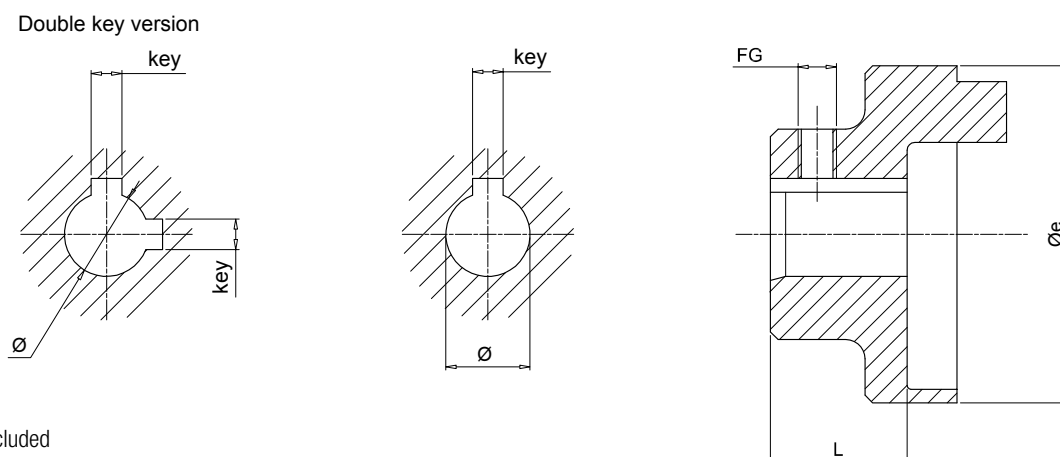

Notes:

- Screw not included
- Double key version pump side only

Motor half-coupling

IEC - Electric motors		Half-coupling code	Dimensions [mm]					Weight [kg]
Motor size	Shaft end [Ø x L]		Øe	L	Ø	key	FG	
63	11x23	SGEA01M01019	44.0	21	11	4	M5	0.07
71	14x30	SGEA01M02028	44.0	28	14	5	M5	0.08
80	19x40	SGEA01M03040	44.0	40	19	6	M5	0.12
		SGEA21M03040	70.0	40	19	6	M6	0.30
90	24x50	SGEA01M04048	44.0	48	24	8	M5	0.13
		SGEA21M04048	70.0	48	24	8	M6	0.28
100 - 112	28x60	SGEA21M05060	70.0	60	28	8	M6	0.33
		SGEA31M05060	85.0	60	28	8	M8	0.48
132	38x80	SGEA21M06080	70.0	80	38	10	M6	0.44
		SGEA31M06077	85.0	77	38	10	M8	0.78
		SGEA51M06077	109.5	77	38	10	M8	1.60
160	42x110	SGEA51M07109	109.5	109	42	12	M8	1.60
180	48x110	SGEA51M08109	109.5	109	48	14	M8	1.60
200	55x110	SGEA51M09109	109.5	109	55	16	M8	1.90

Pump half-couplings

Half-coupling code	Dimensions [mm]				FG	Weight [kg]
	Ø min	Ø max	Øe	L		
SGEK01 *** **	11	19	44.0	25	M5	0.08
SGEK21 *** **	15	28	70.0	35	M6	0.10
SGEK31 *** **	18	42	85.0	45	M8	0.15
SGEK51 *** **	18	55	109.5	50	M8	0.35

Complete the half-coupling code with the shaft's code and length

Example: **SGEK51D02050**

D02 - see page 18

050 - table "pump half coupling - dimension L"

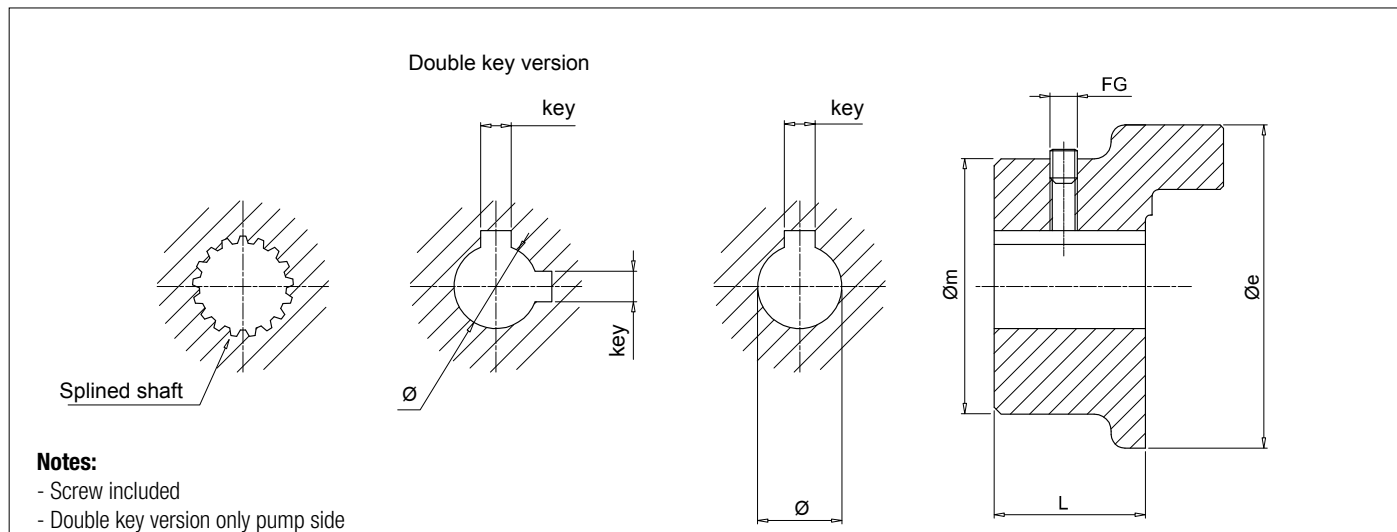
Notes:

- Screw included
- Double key version only pump side

Motor half-coupling

IEC - Electric motors		Half-coupling code	Dimensions [mm]							Weight [kg]
Motor size	Shaft end [Ø x L]		Øe	Øm	L	Ø	key	FG		
63	11x23	SGEG01M01021	40	50	21	11	4	M6	0.32	
71	14x30	SGEG01M02028	40	50	28	14	5	M6	0.42	
80	19x40	SGEG01M03040	40	50	40	19	6	M6	0.61	
90	24x50	SGEG01M04050	40	50	50	24	8	M6	0.77	
100 - 112	28x60	SGEG30M05060	80	65	60	28	8	M8	2.35	
		SGEG40M05060	95	75	60	28	8	M8	2.65	
132	38x80	SGEG30M06080	80	65	80	38	10	M8	3.15	
		SGEG40M06080	95	75	80	38	10	M8	3.55	
160	42x110	SGEG40M07110	95	75	110	42	12	M8	4.70	
180	48x110	SGEG40M08110	95	95	110	48	14	M8	4.55	
200	55x110	SGEG40M09110	95	95	110	55	16	M8	4.35	
		SGEG60M09110	120	98	110	55	16	M8	9.00	
225	60x140	SGEG60M10140	120	118	140	60	18	M8	12.30	
250	65x140	SGEG60M11140	120	118	140	65	18	M8	12.00	
		SGEG80M11140	160	138	140	65	18	M8	18.30	
280	75x140	SGEG80M12140	160	138	140	75	20	M10	17.70	
		SGEG90M12100	200	160	100	75	20	M10	21.00	
315	80x170	SGEG80M13170	160	138	170	80	22	M10	20.60	
		SGEG90M13100	200	160	100	80	22	M10	20.00	
355	95x140	SGEG90M15100	200	160	100	95	25	M10	19.00	
400	100x210	SGEG90M16100	200	160	100	100	28	M10	18.00	

Pump half-couplings

Half-coupling code	Dimensions [mm]				FG	Weight [kg]
	Ø min	Ø max	Øe	L		
SGEK40 *** **	-	55	95	50	M8	3
SGEK60 *** **	-	75	12	65	M8	6
SGEK80 *** **	-	85	160	85	M10	8

Complete the half-coupling code with the shaft's code and length

 Example: **SGEK40PD02050**
PD02 - see page 19

050 - table "pump half coupling - dimension L"

 All SGEK/SGEK series half-couplings are supplied with a grub screw hole as standard, and with a grub screw **UNI 5929 DIN 916** fitted to the hub.

Note: For lengths other than those indicated in "Pump half-coupling" table, contact MP Filtri Technical and Sales Department.

Dimensions

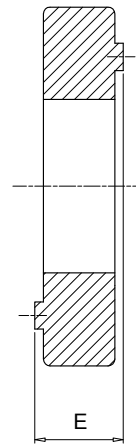
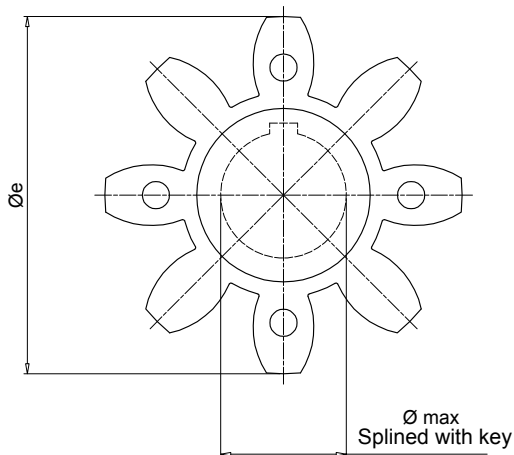

Notes:

Made of black oil-resistant rubber, these components serve to interconnect the two halves (motor - pump) of a flexible coupling.

EGE** series

Code	Half-coupling code		Dimensions [mm]			Nominal torque Nm	Max torque Nm	Weight [kg]
			E	Øe	Ø max			
		RCTAFIT						
EGE0	SGEA01 - SGEG01	SGEK01	15	40	16	10	20	0.006
EGE2	SGEA21	SGEK21	18	65	25	95	190	0.02
EGE3	SGEA31 - SGEG30	SGEK31	22	80	35	190	380	0.04
EGE5	SGEA51	SGEK51	26	105	45	310	620	0.06
EGE4	SGEG40 - SGES40	SGEK40	24	95	40	310	620	0.09
EGE6	SGEG60 - SGES60	SGEK60	28	120	55	430	860	0.13
EGE8	SGEG80 - SGES80	SGEK80	38	160	75	1250	2500	0.36

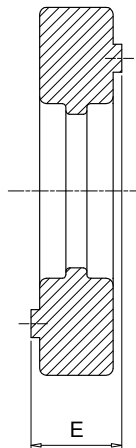
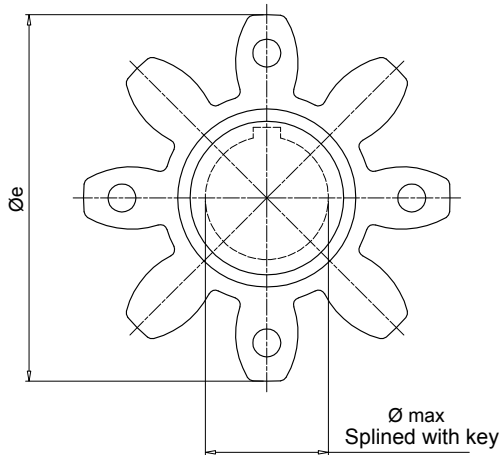

Notes:

Made in polyurethane Laripur - LPR202-95A, red colour, are suitable for applications where high levels of torque are transmitted.

EGE**RR series

Code	Half-coupling code		Dimensions [mm]			Nominal torque Nm	Max torque Nm	Weight [kg]
			E	Øe	Ø max			
		RCTAFIT						
EGE0RR	SGEA01 - SGEG01	SGEK01	15	40	16	15	30	0.006
EGE2RR	SGEA21	SGEK21	18	65	25	115	230	0.02
EGE3RR	SGEA31 - SGEG30	SGEK31	22	80	35	250	500	0.04
EGE5RR	SGEA51	SGEK51	26	105	45	400	800	0.06
EGE4RR	SGEG40 - SGES40	SGEK40	24	95	40	380	760	0.09
EGE6RR	SGEG60 - SGES60	SGEK60	28	120	55	550	1100	0.13
EGE8RR	SGEG80 - SGES80	SGEK80	38	160	75	1400	2900	0.36
EGE9RP	SGEG90	-	45	200	95	5500	6100	0.59

Version for extreme temperatures available on request.

For further information, contact MP Filtri Technical and Sales Department.

Metric cylindrical finish Keyway to DIN 6885 sheet 1

Size	Materials	Diameter / Key [mm]																								
		8	9	10	11	12	13	14	15	15	16	16	17	18	19	19	20	20	22	22	22	24	24	25	25	
01	Aluminium				•	•	•	•	•	•	•	•	•	•	•	•	•	•	•	•	•	•	•	•		
	Steel				•	•	•	•	•	•	•	•	•	•	•	•	•	•	•	•	•	•	•	•		
	Cast Iron				•	•	•	•	•	•	•	•	•	•	•	•	•	•	•	•	•	•	•	•		
21	Aluminium									•	•	•	•	•	•	•	•	•	•	•	•	•	•	•		
	Steel									•	•	•	•	•	•	•	•	•	•	•	•	•	•	•		
	Cast Iron									•	•	•	•	•	•	•	•	•	•	•	•	•	•	•		
31	Aluminium																									
	Steel																									
	Cast Iron																									
40	Aluminium																									
	Steel					•	•	•	•	•	•	•	•	•	•	•	•	•	•	•	•	•	•	•		
	Cast Iron					•	•	•	•	•	•	•	•	•	•	•	•	•	•	•	•	•	•	•		
51	Aluminium																									
	Steel																									
	Cast Iron																									
60	Aluminium																									
	Steel																									
	Cast Iron																									
80	Aluminium																									
	Steel																									
	Cast Iron																									
90	Aluminium																									
	Steel																									
	Cast Iron																									

Size	Materials	Diameter / Key [mm]																								
		28	30	30	32	32	35	35	38	40	42	45	48	50	52	55	60	63	65	70	75	80	82	90	95	100
01	Aluminium																									
	Steel																									
	Cast Iron																									
21	Aluminium	•																								
	Steel	•																								
	Cast Iron																									
31	Aluminium	•	•	•	•	•	•	•	•																	
	Steel	•	•	•	•	•	•	•	•																	
	Cast Iron	•	•	•	•	•	•	•	•																	
40	Aluminium																									
	Steel	•	•	•	•	•	•	•	•	•	•	•														
	Cast Iron	•	•	•	•	•	•	•	•	•	•	•														
51	Aluminium	•	•	•	•	•	•	•	•	•	•	•	•	•	•											
	Steel																									
	Cast Iron																									
60	Aluminium																									
	Steel	•	•	•	•	•	•	•	•	•	•	•	•	•	•	•	•									
	Cast Iron	•	•	•	•	•	•	•	•	•	•	•	•	•	•	•	•									
80	Aluminium																									
	Steel	•	•	•	•	•	•	•	•	•	•	•	•	•	•	•	•	•	•	•	•	•	•	•	•	•
	Cast Iron	•	•	•	•	•	•	•	•	•	•	•	•	•	•	•	•	•	•	•	•	•	•	•	•	•
90	Aluminium																									
	Steel	•	•	•	•	•	•	•	•	•	•	•	•	•	•	•	•	•	•	•	•	•	•	•	•	•
	Cast Iron	•	•	•	•	•	•	•	•	•	•	•	•	•	•	•	•	•	•	•	•	•	•	•	•	•

Imperial cylindrical finish Keyway to DIN 6885 sheet 1

Size	Materials	Diameter / Key [mm]															
		11.11 3.18	12.7 3.18	13.45 3.18	15.87 4.76	15.87 3.97	17.46 4.76	19.02 3.17	19.05 4.76	19.05 6.35	22.22 4.76	22.22 6.35	22.22 4	25.4 6.35	25.4 4.76	26.94 4.76	28.58 6.35
01	Aluminium				•	•	•	•	•	•	•	•	•	•	•	•	•
	Steel				•	•	•	•	•	•	•	•	•	•	•	•	•
	Cast Iron				•	•	•	•	•	•	•	•	•	•	•	•	•
21	Aluminium							•	•	•	•	•	•	•	•	•	
	Steel							•	•	•	•	•	•	•	•	•	
	Cast Iron							•	•	•	•	•	•	•	•	•	
31	Aluminium							•	•	•	•	•	•	•	•	•	
	Steel							•	•	•	•	•	•	•	•	•	
	Cast Iron							•	•	•	•	•	•	•	•	•	
40	Aluminium																
	Steel				•	•	•	•	•	•	•	•	•	•	•	•	
	Cast Iron				•	•	•	•	•	•	•	•	•	•	•	•	
51	Aluminium							•	•	•	•	•	•	•	•	•	
	Steel							•	•	•	•	•	•	•	•	•	
	Cast Iron							•	•	•	•	•	•	•	•	•	
60	Aluminium																
	Steel							•	•	•	•	•	•	•	•	•	
	Cast Iron							•	•	•	•	•	•	•	•	•	
80	Aluminium																
	Steel							•	•	•	•	•	•	•	•	•	
	Cast Iron							•	•	•	•	•	•	•	•	•	
90	Aluminium																
	Steel												•	•	•	•	
	Cast Iron												•	•	•	•	

Size	Materials	Diameter / Key [mm]															
		28.58 7.94	31.75 6.35	31.75 7.94	34.94 7.94	38.1 9.52	41.27 9.52	41.6 12	44.45 11.11	47.63 12.7	50.8 12.7	53.94 12.7	60.33 15.88	60.33 12.7	73.03 19.05	85.73 22.23	92.07 22.22
01	Aluminium	•															
	Steel	•															
	Cast Iron	•															
21	Aluminium	•															
	Steel	•															
	Cast Iron	•															
31	Aluminium	•	•	•	•	•	•	•	•								
	Steel	•	•	•	•	•	•	•	•								
	Cast Iron	•	•	•	•	•	•	•	•								
40	Aluminium																
	Steel	•	•	•	•	•	•	•	•	•	•	•					
	Cast Iron	•	•	•	•	•	•	•	•	•	•	•					
51	Aluminium	•	•	•	•	•	•	•	•	•	•	•	•	•			
	Steel																
	Cast Iron																
60	Aluminium																
	Steel	•	•	•	•	•	•	•	•	•	•	•	•	•	•	•	•
	Cast Iron	•	•	•	•	•	•	•	•	•	•	•	•	•	•	•	•
80	Aluminium																
	Steel	•	•	•	•	•	•	•	•	•	•	•	•	•	•	•	•
	Cast Iron	•	•	•	•	•	•	•	•	•	•	•	•	•	•	•	•
90	Aluminium																
	Steel	•	•	•	•	•	•	•	•	•	•	•	•	•	•	•	•
	Cast Iron	•	•	•	•	•	•	•	•	•	•	•	•	•	•	•	•

SAE involute spline (angle 30°) - ANS.B.92.1.1970

Size	Materials	Nr. of th - Diametral pitch															
		9 16/32	10 16/32	11 16/32	12 16/32	13 16/32	14 16/32	15 16/32	21 16/32	23 16/32	27 16/32	33 16/32	40 16/33	14 12/24	16 12/24	17 12/24	13 8/16
01	Steel	•	•	•	•	•	•	•						•			
	Cast Iron	•	•	•	•	•	•	•						•			
21	Steel	•	•	•	•	•	•	•						•			
	Cast Iron	•	•	•	•	•	•	•						•			
31	Steel	•	•	•	•	•	•	•	•	•	•			•	•	•	•
	Cast Iron	•	•	•	•	•	•	•	•	•	•			•	•	•	•
40	Steel			•	•	•	•	•	•	•	•	•		•	•	•	•
	Cast Iron			•	•	•	•	•	•	•	•	•		•	•	•	•
60	Steel					•	•	•	•	•	•	•		•	•	•	•
	Cast Iron					•	•	•	•	•	•	•		•	•	•	•
80	Steel								•	•	•	•	•		•	•	•
	Cast Iron								•	•	•	•	•		•	•	•
90	Steel								•	•	•	•	•		•	•	•
	Cast Iron								•	•	•	•	•		•	•	•

Size	Materials	Nr. of th - Diametral pitch														
		15 8/16	17 8/16	20 24/48	21 24/48	23 24/48	25 24/48	26 24/48	28 24/48	29 24/48	32 24/48	23 40/80	36 48/96	41 48/96	47 48/96	33 32/64
01	Steel			•	•	•			•	•		•	•	•	•	
	Cast Iron			•	•	•			•	•		•	•	•	•	
21	Steel			•	•	•	•	•	•	•		•	•	•	•	
	Cast Iron			•	•	•	•	•	•	•		•	•	•	•	
31	Steel	•		•	•	•	•	•	•	•	•	•	•	•	•	
	Cast Iron	•		•	•	•	•	•	•	•	•	•	•	•	•	•
40	Steel	•	•	•	•	•	•	•	•	•	•	•	•	•	•	•
	Cast Iron	•	•	•	•	•	•	•	•	•	•	•	•	•	•	•
60	Steel	•	•	•	•	•	•	•	•	•	•			•	•	•
	Cast Iron	•	•	•	•	•	•	•	•	•	•			•	•	•
80	Steel	•	•								•					•
	Cast Iron	•	•								•					•
90	Steel	•	•								•					•
	Cast Iron	•	•								•					•

Spline bores to DIN 5480

Size	Materials	Nr. of th - Size										
		13 18x1.25	14 20x1.25	14 30x2	14 32x2	16 35x2	17 37x2	18 25x1.25	18 38x2	18 40x2	20 42x2	18 60x3
01	Steel	•	•									
	Cast Iron	•	•									
21	Steel	•	•	•	•	•		•				
	Cast Iron	•	•	•	•	•		•				
31	Steel	•	•	•	•	•	•	•				
	Cast Iron	•	•	•	•	•	•	•				
40	Steel	•	•	•	•	•	•	•	•	•	•	
	Cast Iron	•	•	•	•	•	•	•	•	•	•	
60	Steel	•	•	•	•	•	•	•	•	•	•	•
	Cast Iron	•	•	•	•	•	•	•	•	•	•	•
80	Steel				•	•	•		•	•	•	•
	Cast Iron				•	•	•		•	•	•	•
90	Steel								•	•	•	•
	Cast Iron								•	•	•	•

Size	Materials	Nr. of th - Size									
		21 28x1.25	21 45x2	22 70x3	24 32x1.25	24 50x2	26 55x2	28 60x2	29 38x1.25	34 70x2	38 80x2
01	Steel										
	Cast Iron										
21	Steel	•									
	Cast Iron	•									
31	Steel	•			•				•		
	Cast Iron	•			•				•		
40	Steel	•	•		•				•		
	Cast Iron	•	•		•				•		
60	Steel	•	•		•	•	•	•	•		
	Cast Iron	•	•		•	•	•	•	•		
80	Steel		•	•	•	•	•	•	•	•	•
	Cast Iron		•	•	•	•	•	•	•	•	•
90	Steel		•	•		•	•	•	•	•	•
	Cast Iron		•	•		•	•	•	•	•	•

Spline bores to DIN 5481

Size	Materials	Nr. of th - Size									
		28 8x10	30 10x12	31 12x14	32 15x17	33 17x20	34 21x24	35 26x30	36 38x34	41 60x65	
01	Steel	•	•	•	•	•	•				
	Cast Iron	•	•	•	•	•	•				
21	Steel	•	•	•	•	•	•	•			
	Cast Iron	•	•	•	•	•	•	•			
31	Steel			•	•	•	•	•	•		
	Cast Iron			•	•	•	•	•	•		
40	Steel							•	•	•	
	Cast Iron							•	•	•	
60	Steel								•	•	•
	Cast Iron								•	•	•
80	Steel										•
	Cast Iron										•
90	Steel										•
	Cast Iron										•

Spline bores to DIN 5482

Size	Materials	Nr. of th - Size															
		8 A15x12	9 A17x14	10 A18x15	12 A20x17	13 A22x19	14 A25x22	15 A28x25	16 A30x27	17 A32x28	18 A35x31	19 A38x34	20 A40x36	21 A42x38	22 A45x41	23 A48x44	24 A50x45
01	Steel	•	•	•	•	•	•										
	Cast Iron	•	•	•	•	•	•										
21	Steel	•	•	•	•	•	•	•	•	•	•						
	Cast Iron	•	•	•	•	•	•	•	•	•	•						
31	Steel							•	•	•	•	•					
	Cast Iron							•	•	•	•	•					
40	Steel																
	Cast Iron																
60	Steel																
	Cast Iron																
80	Steel																
	Cast Iron																
90	Steel																
	Cast Iron																

Size	Materials	Nr. of th - Size														
		25 A52x47	26 A55x50	27 A58x53	28 A60x55	29 A62x57	30 A65x60	31 A68x62	32 A70x64	33 A72x66	34 A75x69	35 A78x72	36 A80x74	37 A82x76	38 A85x79	39 A88x82
01	Steel															
	Cast Iron															
21	Steel															
	Cast Iron															
31	Steel															
	Cast Iron															
40	Steel	•	•													
	Cast Iron	•	•													
60	Steel	•	•	•	•	•	•	•								
	Cast Iron	•	•	•	•	•	•	•								
80	Steel	•	•	•	•	•	•	•	•	•	•	•	•	•	•	•
	Cast Iron	•	•	•	•	•	•	•	•	•	•	•	•	•	•	•
90	Steel	•	•	•	•	•	•	•	•	•	•	•	•	•	•	•
	Cast Iron	•	•	•	•	•	•	•	•	•	•	•	•	•	•	•

AKG series

IEC electric motor range from size 63 up to size 225



Technical data

Couplings - IEC electric motor range from size 63 up to size 225

Materials

- Hubs: Aluminium, cast iron, steel
- Spider materials: NBR rubber 87 Sh A
Polyurethane 95 Sh A

Compatibility with fluids

- Modular bell-housing components compatible for use with:
- Mineral oils types HH-HL-HM-HR-HV, to ISO 6743/4 standard
 - Water based emulsions types HFAE-HFAS, to ISO 6743/4 standard
 - Water glycol type HFC, to ISO 6743/4 standard: ask for anodized version

Special Applications

Any applications not covered by the normal indications contained in this catalogue must be evaluated and approved by MP Filtri Technical and Sales Department

Temperature

From -30 °C to +80 °C

Note

For temperatures outside this range, contact MP Filtri Technical and Sales Department





Standard ATEX Directive 2014/34/EU and UK Regulation S.I. 2016 No. 1107 (as amended).

On request, it's possible to certificate the AKG according to ATEX CAT. 2G - Areas 1 - 2



IEC Electric motors

Coupling size	European standard size						German standard size			IEC Motors size
	0.5	1	2	3	3.5	4	ZB	ZF	ZG	
AKG02	●	●	●				●			IEC 63 Ø140 - Ø11x23
AKG03	●	●	●				●			IEC 71 Ø160 - Ø14x30
AKG04	●	●	●	●			●	●		IEC 80 Ø200 - Ø19x40
AKG05	●	●	●	●			●	●		IEC 90 Ø200 - Ø24x50
AKG07		●	●	●			●	●		IEC 110 Ø250 - Ø28x60
AKG07		●	●	●			●	●		IEC 112 Ø250 - Ø28x60
AKG11		●	●	●	●	●		●	●	IEC 132 Ø300 - Ø38x80
AKG12			●	●	●	●	●	●	●	IEC 160 Ø350 - Ø42x110
AKG13			●	●	●	●	●	●	●	IEC 180 Ø350 - Ø48x110
AKG16			●	●	●	●	●	●	●	IEC 200 Ø400 - Ø55x110
AKG18			●	●	●	●	●	●	●	IEC 225 Ø450 - Ø60x140

KIT COUPLING FOR GEAR PUMPS

Motors identification code		Configuration example: AKG02 FS200 Z EX			
Size	Size				
02 63 B3-B5	13 180 B3-B5				
03 71 B3-B5	43 63 B14				
04 80 B3-B5	44 71 B14				
05 90 B3-B5	45 80 B14				
07 100/112 B3-B5	46 90 B14				
11 132 B3-B5	48 100/112 B14				
12 160 B3-B5					
Pump flange identification code					
FS200 See pages 43 - 44 - 45					
Pump identification code					
Z Revision index					
ATEX certification identification code					
EX ATEX Directive 2014/34/EU and UK Regulation S.I. 2016 No. 1107 (as amended)					

KIT COUPLING FOR PISTON PUMPS VANES AND SCREWS

Motors identification code		Configuration example: AKG M01 Z0000 EX			
Size	Size				
M01 80 B3-B5	M07 200 B3-B5				
M02 90 B3-B5	M08 225 B3-B5				
M03 100/112 B3-B5	M09 250 B3-B5				
M04 132 B3-B5	M10 280 B3-B5				
M05 160 B3-B5	M11 315 B3-B5				
M06 180 B3-B5	M12 355 B3-B5				
Electric motor identification code					
M01 See software					
Pump identification code					
Z0000 See software					
ATEX certification identification code					
EX ATEX Directive 2014/34/EU and UK Regulation S.I. 2016 No. 1107 (as amended)					

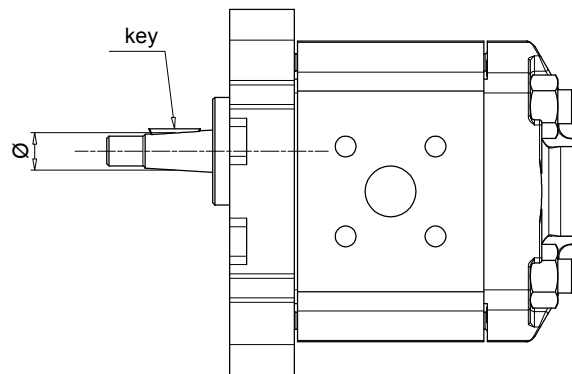

Shaft identification

Pump group	d	Key	Shaft type	Pump half-coupling code
05	6.0	2.0	parallel	FS05M
	7.0	2.0	parallel	FS05C
1	9.7	2.4	tapered 1:8	FS100
	12.0	3.0	parallel	FS1C0
	13.9	3.0	tapered 1:8	FS1M0
2	17.2	3.2 - 4	tapered 1:8	FS200
	22.2	4.0	tapered 1:8	FS300
3	22.2	4.0	tapered 1:8	FS300
	22.2	4.0	tapered 1:8	FS300
	22.2	4.0	tapered 1:8	FS300
	22.2	4.0	tapered 1:8	FS300
3.5	25.6	4.76 - 5.0	tapered 1:8	FS350
	25.6	4.76 - 5.0	tapered 1:8	FS350
4	33.3	6.35 - 7.0	tapered 1:8	FS400
	33.3	6.35 - 7.0	tapered 1:8	FS400
Bosch	9.8	2.0	tapered 1:5	FSZBR
	16.9	3.0	tapered 1:5	FSZFR
	25.2	5.0	tapered 1:5	FSZGR

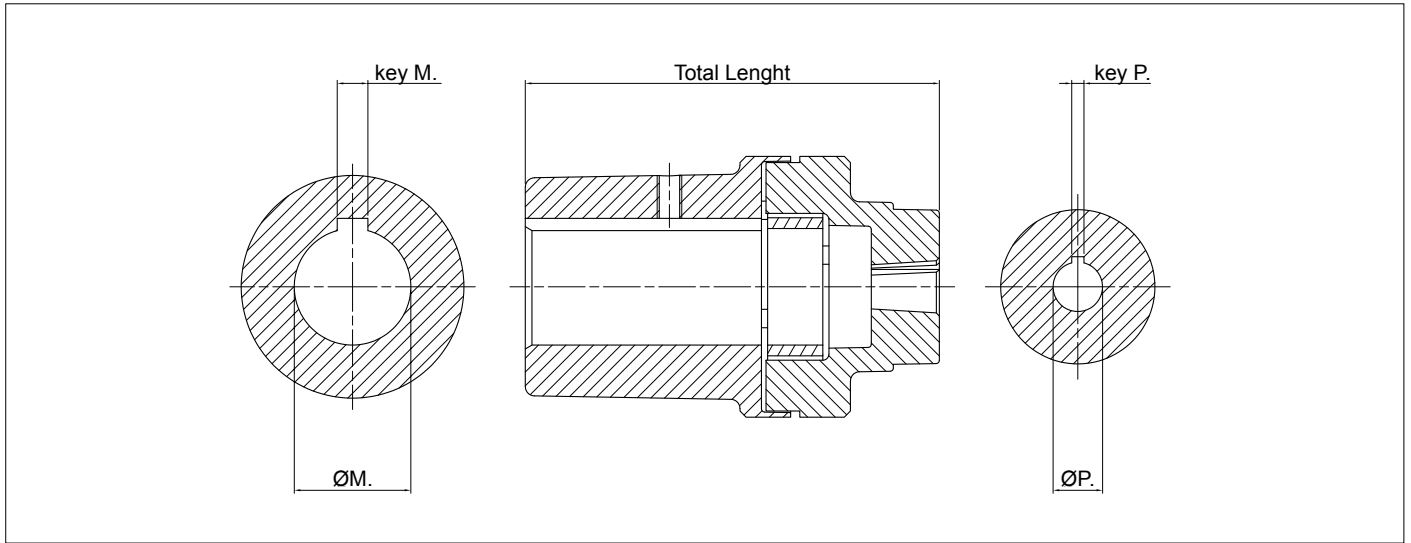

IEC Motors B3/5 - standard gear pump

IEC - Electric motors		Pump identification code	Components														
Motor size	Shaft end [Ø x L]		Motor half-coupling code	Spider code	Codice Semigiunto pompa	Complete coupling kit code	ØM.	Key M.	ØP.	Key P.	Tot. L.						
63	11x23	FS05M	SGEA01M01019	EGE 0	SGEA01FS05M	AKG02FS05MZEX	11	4	6	2	50						
		FS05C			SGEA01FS05C	AKG02FS05CZEX			7	2							
		FS100			SGEA01FS100	AKG02FS100ZEX			9.7-1.8	2.4							
		FS1C0			SGEA01FS1C0	AKG02FS1C0ZEX			12	3							
		FS1M0			SGEA01FS1M0	AKG02FS1MOZEX			13.9-1.8	3							
		FSZBR			SGEA01FSZBR	AKG02FSZBRZEX			9.8-1.5	2							
71	14x30	FS05M	SGEA01M02028	EGE 0	SGEA01FS05M	AKG03FS05MZEX	14	5	6	2	59						
		FS05C			SGEA01FS05C	AKG03FS05CZEX			7	2							
		FS100			SGEA01FS100	AKG03FS100ZEX			9.7-1.8	2.4							
		FS1C0			SGEA01FS1C0	AKG03FS1C0ZEX			12	3							
		FS1M0			SGEA01FS1M0	AKG03FS1MOZEX			13.9-1.8	3							
		FSZBR			SGEA01FSZBR	AKG03FSZBRZEX			9.8-1.5	2							
80	19x40	FS05M	SGEA01M03048	EGE 0	SGEA01FS05M	AKG04FS05MZEX	19	6	6	2	80						
		FS05C			SGEA01FS05C	AKG04FS05CZEX			7	2							
		FS100			SGEA01FS100	AKG04FS100ZEX			9.7-1.8	2.4							
		FS1C0			SGEA01FS1C0	AKG04FS1C0ZEX			12	3							
		FS1M0			SGEA01FS1M0	AKG04FS1MOZEX			13.9-1.8	3							
		FSZBR			SGEA01FSZBR	AKG04FSZBRZEX			9.8-1.5	2							
			FS200	SGEA21M03048	EGE 2	SGEA21FS200	AKG04FS200ZEX	19	6	17.2-1.8	3.5/4	94					
			FSZFR			SGEA21FSZFR	AKG04FSZFRZEX			16.9	3						
			FS05M			SGEA01M04048	EGE 0			SGEA01FS05M	AKG05FS05MZEX		24	8	6	2	80
			FS05C							SGEA01FS05C	AKG05FS05CZEX				7	2	
FS100	SGEA01FS100	AKG05FS100ZEX	9.7-1.8	2.4													
FS1C0	SGEA01FS1C0	AKG05FS1C0ZEX	12	3													
FS1M0	SGEA01FS1M0	AKG05FS1MOZEX	13.9-1.8	3													
FSZBR	SGEA01FSZBR	AKG05FSZBRZEX	9.8-1.5	2													
		FS200	SGEA21M04048	EGE 2	SGEA21FS200	AKG05FS200ZEX	24	8	17.2-1.8	3.5/4	94						
		FSZFR			SGEA21FSZFR	AKG05FSZFRZEX			16.9	3							
100 112	28x60	FS100	SGEA21M05055	EGE 2	SGEA21FS100	AKG07FS100ZEX	28	8	9.7-1.8	2.4	94						
		FS1C0			SGEA21FS1C0	AKG07FS1C0ZEX			12	3							
		FS1M0			SGEA21FS1M0	AKG07FS1MOZEX			13.9-1.8	3							
		FSZBR			SGEA21FSZBR	AKG07FSZBRZEX			25.2-1.5	5							
		FS200			SGEA21FS200	AKG07FS200ZEX			17.2-1.8	3.2/4							
		FSZFR			SGEA21FSZFR	AKG07FSZFRZEX			16.9-1.5	3							
		FS25T			SGEA21FS300	AKG07FS300ZEX			22.22-1.8	4							
		FS300			SGEA21FS300	AKG07FS300ZEX			22.22-1.8	4							
		FS3M0			SGEA21FS300	AKG07FS300ZEX			22.22-1.8	4							
		FS3T0			SGEA21FS300	AKG07FS300ZEX			22.22-1.8	4							

IEC Motors B3/5 - standard gear pump

IEC - Electric motors Motor size	Shaft end [Ø x L]	Pump identification code	Components								
			Motor half-coupling code	Spider code	Pump half-coupling code	Complete coupling kit code	ØM.	Key M.	ØP.	Key P.	Tot. L.
132	38x80	FS100	SGEA31M06077	EGE 3	SGEA31FS100	AKG11FS100ZEX	38	10	9.7-1.8	2.4	135
		FS1C0			SGEA31FS1C0	AKG11FS1C0ZEX			12	3	
		FS1M0			SGEA31FS1M0	AKG11FS1M0ZEX			13.9-1.8	3	
		FSZGR			SGEA31FSZGR	AKG11FSZGRZEX			25.2-1.5	5	
		FS200			SGEA31FS200	AKG11FS200ZEX			17.2-1.8	3.2/4	
		FSZFR			SGEA31FSZFR	AKG11FSZFRZEX			16.9-1.5	3	
		FS25T			SGEA31FS25T	AKG11FS25TZEX			22.22-1.8	4	
		FS300			SGEA31FS300	AKG11FS300ZEX			22.22-1.8	4	
		FS3M0			SGEA31FS3M0	AKG11FS3M0ZEX			22.22-1.8	4	
		FS3T0			SGEA31FS3T0	AKG11FS3T0ZEX			22.22-1.8	4	
		FS35M			SGEA31FS35M	AKG11FS35MZEX			25.6-1.5	4.76/5	
		FS350			SGEA31FS350	AKG11FS350ZEX			25.6-1.5	4.76/5	
160	42x110	FSZGR	SGEA51M07109	EGE 5	SGEA51FSZGR	AKG12FSZGRZEX	42	12	25.2-1.5	5	167
		FS200			SGEA51FS200	AKG12FS200ZEX			17.2-1.8	3.2/4	
		FSZFR			SGEA51FSZFR	AKG12FSZFRZEX			16.9-1.5	3	
		FS25T			SGEA51FS25T	AKG12FS25TZEX			22.22-1.8	4	
		FS300			SGEA51FS300	AKG12FS300ZEX			22.22-1.8	4	
		FS3M0			SGEA51FS3M0	AKG12FS3M0ZEX			22.22-1.8	4	
		FS3T0			SGEA51FS3T0	AKG12FS3T0ZEX			22.22-1.8	4	
		FS35M			SGEA51FS35M	AKG12FS35MZEX			25.6-1.5	4.76/5	
		FS350			SGEA51FS350	AKG12FS350ZEX			25.6-1.5	4.76/5	
		180			48x110	FSZGR			SGEA51M08109	EGE 5	
FS200	SGEA51FS200		AKG13FS200ZEX	17.2-1.8		3.2/4					
FSZFR	SGEA51FSZFR		AKG13FSZFRZEX	16.9-1.5		3					
FS25T	SGEA51FS25T		AKG13FS25TZEX	22.22-1.8		4					
FS300	SGEA51FS300		AKG13FS300ZEX	22.22-1.8		4					
FS3M0	SGEA51FS3M0		AKG13FS3M0ZEX	22.22-1.8		4					
FS3T0	SGEA51FS3T0		AKG13FS3T0ZEX	22.22-1.8		4					
FS35M	SGEA51FS35M		AKG13FS35MZEX	25.6-1.5		4.76/5					
FS350	SGEA51FS350		AKG13FS350ZEX	25.6-1.5		4.76/5					
200	55x110		FS200	SGEA51M09109		EGE 5	SGEA51FS200	AKG16FS200ZEX			55
		FS300	SGEA51FS300		AKG16FS300ZEX		22.22-1.8	4			
		FS3M0	SGEA51FS3M0		AKG16FS3M0ZEX		22.22-1.8	4			
		FS35M	SGEA51FS35M		AKG16FS35MZEX		25.6-1.5	4.76/5			
		FS350	SGEA51FS350		AKG16FS350ZEX		25.6-1.5	4.76/5			
		FSZFR	SGEA51FSZFR		AKG16FSZFRZEX		16.9-1.5	3			
		FSZGR	SGEA51FSZGR		AKG16FSZGRZEX		25.2-1.5	5			
225	60x140	FS300	SGEG60M10110	EGE 6	SGEG60FS300	AKG18FS300ZEX	60	18	22.22-1.8	4	167
		FS3M0			SGEG60FS3M0	AKG18FS3M0ZEX			22.22-1.8	4	
		FS35M			SGEG60FS35M	AKG18FS35MZEX			25.6-1.5	4.76/5	
		FS350			SGEG60FS350	AKG18FS350ZEX			25.6-1.5	4.76/5	
		FSZGR			SGEG60FSZGR	AKG18FSZGRZEX			25.2-1.5	5	
250	65x140	FS300	SGEG60M11140	EGE 6	SGEG60FS300	AKG20FS300ZEX	65	18	22.22-1.8	4	168
		FS3M0			SGEG60FS3M0	AKG20FS3M0ZEX			22.22-1.8	4	
		FS35M			SGEG60FS35M	AKG20FS35MZEX			25.6-1.5	4.76/5	
		FS350			SGEG60FS350	AKG20FS350ZEX			25.6-1.5	4.76/5	
		FSZGR			SGEG60FSZGR	AKG20FSZGRZEX			25.2-1.5	5	
280	75x140	FS300	SGEG80M12140	EGE 8	SGEG80FS300	AKG22FS300ZEX	75	20	22.22-1.8	4	198
		FS3M0			SGEG80FS3M0	AKG22FS3M0ZEX			22.22-1.8	4	
		FS35M			SGEG80FS35M	AKG22FS35MZEX			25.6-1.5	4.76/5	
		FS350			SGEG80FS350	AKG22FS350ZEX			25.6-1.5	4.76/5	
		FSZGR			SGEG80FSZGR	AKG22FSZGRZEX			25.2-1.5	5	
315	80x170	FS300	SGEG80M13170	EGE 8	SGEG80FS300	AKG26FS300ZEX	80	22	22.22-1.8	4	228
		FS3M0			SGEG80FS3M0	AKG26FS3M0ZEX			22.22-1.8	4	
		FS35M			SGEG80FS35M	AKG26FS35MZEX			25.6-1.5	4.76/5	
		FS350			SGEG80FS350	AKG26FS350ZEX			25.6-1.5	4.76/5	
		FSZGR			SGEG80FSZGR	AKG26FSZGRZEX			25.2-1.5	5	

IEC Electric motors B14 mounting

IEC - Electric motors		Pump identification code	Components													
Motor size	Shaft end [Ø x L]		Motor half-coupling code	Spider code	Pump half-coupling code	Complete coupling kit code	ØM.	Key M.	ØP.	Key P.	Tot. L.					
63	11x23	FS05M	SGEA01M01019	EGE0	SGEA00FS05M	AKG43FS05MZEX	11	4	6	2	50					
		FS05C			SGEA01FS05C	AKG43FS05CZEX			7	2						
		FS100			SGEA01FS100	AKG43FS100ZEX			9.7-1:8	2.4						
		FS1C0			SGEA01FS1C0	AKG43FS1C0ZEX			12	3						
		FS1M0			SGEA01FS1M0	AKG43FS1M0ZEX			13.9-1:8	3						
		FSZBR			SGEA01FSZBR	AKG43FSZBRZEX			9.8-1:5	2						
71	14x30	FS05M	SGEA01M02028	EGE 0	SGEA01FS05M	AKG44FS05MZEX	14	5	6	2	59					
		FS05C			SGEA01FS05C	AKG44FS05CZEX			7	2						
		FS100			SGEA01FS100	AKG44FS100ZEX			9.7-1:8	2.4						
		FS1C0			SGEA01FS1C0	AKG44FS1C0ZEX			12	3						
		FS1M0			SGEA01FS1M0	AKG44FS1M0ZEX			13.9-1:8	3						
		FSZBR			SGEA01FSZBR	AKG44FSZBRZEX			9.8-1:5	2						
80	19x40	FS05M	SGEA01M03048	EGE 0	SGEA01FS05M	AKG45FS05MZEX	19	6	6	2	79					
		FS05C			SGEA01FS05C	AKG45FS05CZEX			7	2						
		FS100			SGEA01FS100	AKG45FS100ZEX			9.7-1:8	2.4						
		FS1C0			SGEA01FS1C0	AKG45FS1C0ZEX			12	3						
		FS1M0			SGEA01FS1M0	AKG45FS1M0ZEX			13.9-1:8	3						
		FSZBR			SGEA01FSZBR	AKG45FSZBRZEX			9.8-1:5	2						
	FS200	SGEA21M03048	EGE 2	SGEA21FS200	AKG45FS200ZEX	19	6	17.2-1:8	3.2/4	87						
				FSZFR	SGEA21FSZFR			AKG45FSZFRZEX	16.9		3					
90	24x50	FS05M	SGEA01M04048	EGE 0	SGEA01FS05M	AKG46FS05MZEX	24	8	6	2	79					
		FS05C			SGEA01FS05C	AKG46FS05CZEX			7	2						
		FS100			SGEA01FS100	AKG46FS100ZEX			9.7-1:8	2.4						
		FS1C0			SGEA01FS1C0	AKG46FS1C0ZEX			12	3						
		FS1M0			SGEA01FS1M0	AKG46FS1M0ZEX			13.9-1:8	3						
		FSZBR			SGEA01FSZBR	AKG46FSZBRZEX			9.8-1:5	2						
	FS200	SGEA21M04048	EGE 2	SGEA21FS200	AKG46FS200ZEX	24	8	17.2-1:8	3.5/4	87						
				FSZFR	SGEA21FSZFR			AKG46FSZFRZEX	16.9		3					
100 112	28x60	FS05M	SGEA21M05055	EGE 2	SGEA21FS05M	AKG48FS05MZEX	28	8	6	2	94					
		FS05C			SGEA21FS05C	AKG48FS05CZEX			7	2						
		FS100			SGEA21FS100	AKG48FS100ZEX			9.7-1:8	2.4						
		FS1C0			SGEA21FS1C0	AKG48FS1C0ZEX			12	3						
		FS1M0			SGEA21FS1M0	AKG48FS1M0ZEX			13.9-1:8	3						
		FSZBR			SGEA21FSZBR	AKG48FSZBRZEX			9.8-1:5	2						
		FS200			SGEA21FS200	EGE 2			SGEA21FS200	AKG48FS200ZEX		28	8	17.2-1:8	3.5/4	94
									FSZFR	SGEA21FSZFR				AKG48FSZFRZEX	16.9	

SGDR series

Curved-tooth steel gear coupling



Technical data

Couplings - Curved-tooth steel gear coupling

Gear couplings materials

Couplings: Steel C40

Sleeve: Polyamide PA66 Blue color

Compatibility with fluids

- Mineral oils types HH-HL-HM-HR-HV, to ISO 6743/4 standard
- Water based emulsions types HFAE-HFAS, to ISO 6743/4 standard
- Water glycol type HFC, to ISO 6743/4 standard: ask for anodized version

Special Applications

Any applications not covered by the normal indications contained in this catalogue must be evaluated and approved by MP Filtri Technical and Sales Department

Temperature

Sleeve Polyamide PA66: from -20 °C to +90 °C

Note

For temperatures outside this range, contact MP Filtri Technical and Sales Department



IEC Electric motors

IEC Electric Motors size	C40 Carbon Steel				
	Shaft ISO 3019-2	Shaft ANSI B92. 1A 1976	Shaft DIN 5480	Shaft DIN 5481	Shaft DIN 5482
IEC 80 Ø200 - Ø19x40	●	●	●	●	●
IEC 90 Ø200 - Ø24x50	●	●	●	●	●
IEC 100 Ø250 - Ø28x60	●	●	●	●	●
IEC 112 Ø250 - Ø28x60	●	●	●	●	●
IEC 132 Ø300 - Ø38x80	●	●	●	●	●
IEC 160 Ø350 - Ø42x110	●	●	●	●	●
IEC 180 Ø350 - Ø48x110	●	●	●	●	●
IEC 200 Ø400 - Ø55x110	●	●	●	●	●

BLANK HALF-COUPLING

Pump half-coupling SGDR	Configuration example: SGDR 28 PB
Size 28 42 55	
Without bore PB	

HALF-COUPLING FOR PARALLEL SHAFT

Pump half-coupling SGDR	Configuration example: SGDR 28 G02 040 2E
Size 28 42 55	
Bore size code G02 See page 18	
Length 040 See page 50	
Double key way (available combinations only) 2E See page 18 (Parallel shaft - double key only)	

HALF-COUPLING FOR SPLINED SHAFT

Pump half-coupling SGDR	Configuration example: SGDR 28 PD02 040
Size 28 42 55	
Bore size code PD02 See page 19	
Length 040 See page 50	

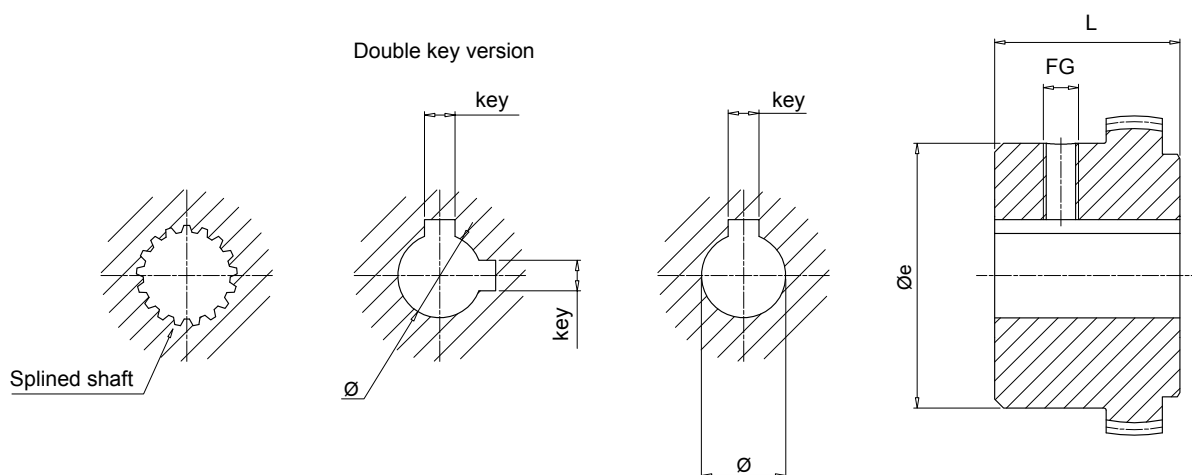

Notes:

- Screw included
- Double key version only pump side

Motor half-coupling

IEC - Electric motors		Half-coupling code	Dimensions [mm]					Weight [kg]
Motor size	Shaft end [Ø x L]		Øe	L	Ø	key	Fg	
80	19x40	SGDR28M03040	45	40	19	6	M6	0.5
90	24x50	SGDR28M04040	45	40	24	8	M6	0.5
100-112	28x60	SGDR28M05040	45	40	28	8	M6	0.5
132	38x80	SGDR42M06042	60	42	38	10	M8	1.0
160	42x110	SGDR42M07042	60	42	42	12	M8	1.0
180	48x110	SGDR55M08060	84	60	48	14	M8	2.5
200	55x110	SGDR55M09060	84	60	55	16	M8	2.5

Pump half-couplings

Half-coupling code	Dimensions [mm]		Weight [kg]
	Øe	L	
SGDR28***	45	40	0.5
SGDR42***	60	42	1.0
SGDR55***	84	60	2.5

Complete the half-coupling designation with the pump interface code and the length.

Example: **SGDR280PD02050** (see page 19).

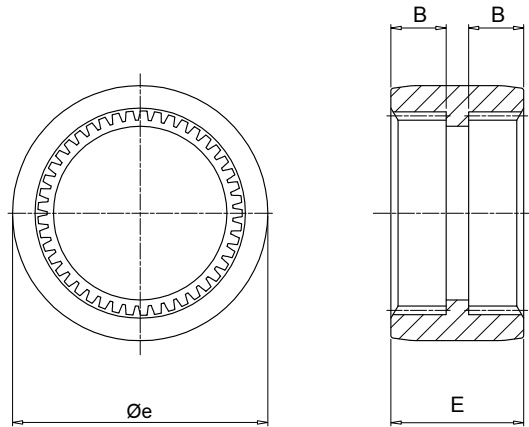

Sleeve

Code	Half-coupling code	Dimensions [mm]			Nominal torque [Nm]	Maximum torque [Nm]	Weight [kg]
		Øe	E	B			
EGR066PA	SGDR28	66	38	16	30	90	0.050
EGR090PA	SGDR42	90	52	22	120	360	0.150
EGR125PA	SGDR55	125	65	27	200	600	0.371

COMPONENTS FOR e-PTO SYSTEMS



e-PTO CONCEPT

Designed to power the onboard hydraulic systems of heavy vehicles, such as waste collection vehicles and cranes, the e-PTO uses the electric energy of a Banke e-PTO instead of traditional diesel. This innovation represents a significant step towards sustainability and energy efficiency in the industrial vehicle sector.

One of the main advantages of the e-PTO is its quiet operation and zero CO₂ emissions. This system allows for up to a 50% reduction in the energy consumed by onboard hydraulic systems.

The e-PTO system consists of:

- **Aluminum lantern:** customizable based on the pump mounted by the manufacturer
- **Steel half-coupling:** engine side with integrated shaft, ensuring robustness and reliability
- **Polyurethane elastic insert:** for a flexible and durable connection
- **Pump side half-coupling:** customizable based on the mounted pump
- **Hydraulic pump:** chosen by the manufacturer for equipment movement
- **Intelligent electronic control system:** manages the entire process to ensure efficiency and reliability.

Versatile Applications

The e-PTO is particularly suitable for vehicle outfitters who build:

- Loader cranes
- Refrigerated vehicles
- Cement mixers
- Urban distribution vehicles
- Dumper
- Aircraft Tug
- Sweeper machines.

Technical data

Couplings - Solutions for e-PTO

Half-couplings materials

SGES: Steel C40

Spider materials

EGE**RR series: in polyurethane Laripur - 92 Shore A - LPR202-95A - red colour

Compatibility with fluids

- Mineral oils types HH-HL-HM-HR-HV, to ISO 6743/4 standard
- Water based emulsions types HFAE-HFAS, to ISO 6743/4 standard
- Water glycol type HFC, to ISO 6743/4 standard: ask for anodized version

Temperature

Spider polyurethane resin: from -30 °C to +120 °C

Note

For temperatures outside this range, contact MP Filtri Technical and Sales Department

Ordering code

Motor half-coupling code: **SGES21IS04156**

The MP Filtri solution includes

Customisable pump-side half-coupling situated on the mounted pump

Polyurethane elastic insert

New motor-side steel half-coupling with integrated shaft

Aluminium bell-housing customisable according to the mounted pump



e-PTO
Brochure

Dimensions

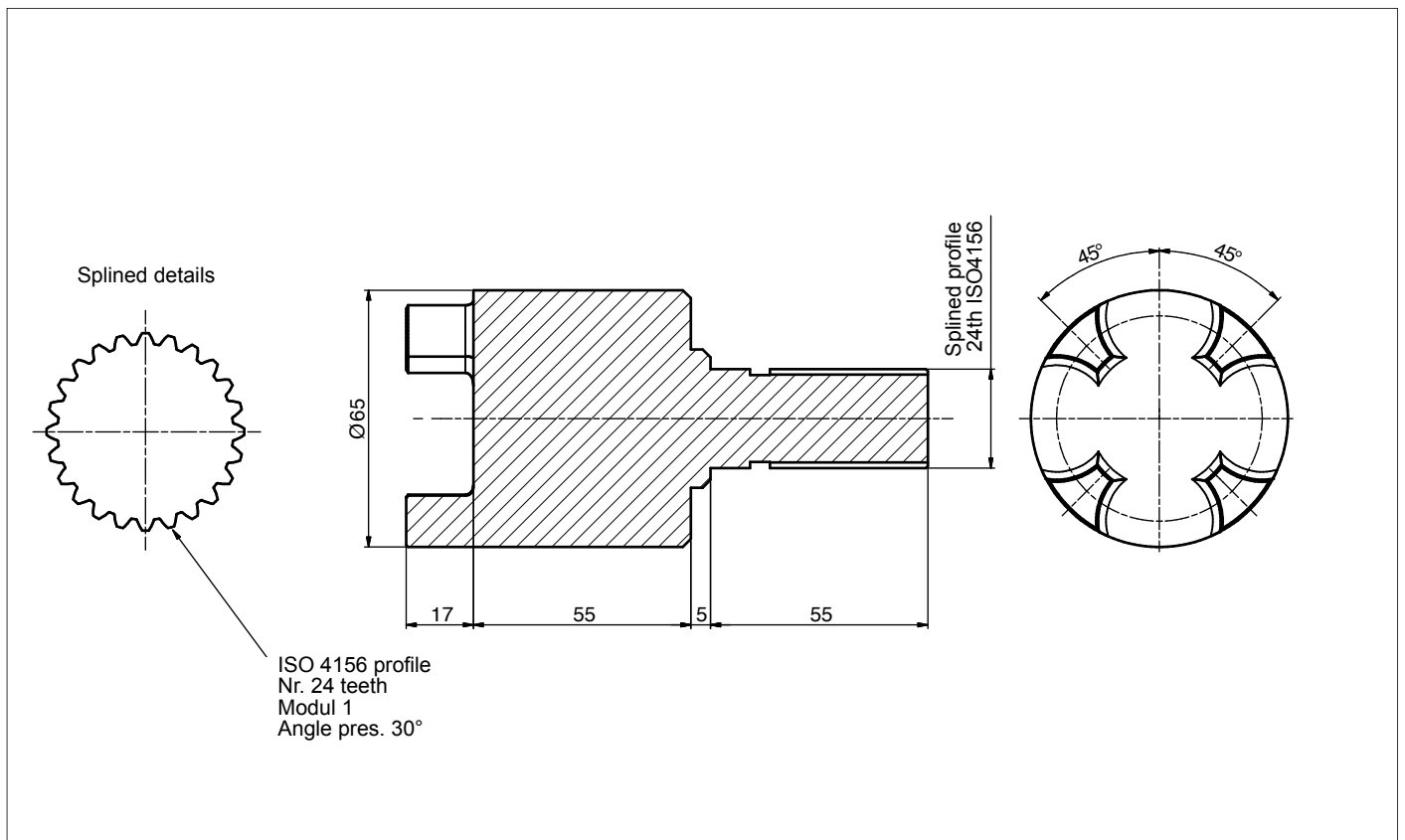

Notes:

Please contact the Technical Department to discuss possible combinations between the electric motor installed on the machine and the pump mounted on the vehicle.

Bell-Housing are used as connecting elements between IEC motors and engine motors with wide range of hydraulic pumps available on the international market.

Made in Aluminum die cast, they cover a range from IEC motor size 63 to IEC motor size 355 and engine motors from 2 Hp to 15 Hp.

They are available in six different styles:

- LMG series for gear pumps
- LMC series monobloc bell-housing
- LDC series made in 2 pcs fixed by screws
- LMS series able to reduce the noise
- LDS series made in 2 pcs fixed by screws
- MULTI-COMPONENTS made by 3 pcs for IEC motors from sizes 132 up to size 225,
made by 2 pcs for IEC motors from size 250 up to size 355
- LME series for engine motors

Bell-Housings



GENERAL INFORMATION	page 58
LMG	63
LMC - LDC	75
LMS - LDS	83
MULTI-COMPONENTS	91
LME	113

Noise is a particularly pervasive problem so much so that there have been statutory regulations in place now for some years, designed to limit harmful occupational exposure.

Many of the machines used in industry today are equipped with oil-hydraulic systems, which happen to be a major source of noise.

① THEORY AND DEFINITION OF NOISE

From a health and hygiene standpoint, noise can be defined as an unpleasant and undesirable sound, or an unpleasant and annoying or intolerable auditory sensation (noise being any sound phenomena that may be accompanied by sensations of disturbance and pain). By definition, acoustic phenomena are oscillatory in character, propagated in a flexible medium and causing pressure variations at the points, and the areas adjacent to those points, through which they pass.

② SOUND

Technically considered, certain elements must be present simultaneously for acoustic phenomena to occur:

- Sound source
- Transmission medium
- Receive

The electric motor and the pump, together with the drive coupling, are the SOURCE OF THE NOISE. The Bell-housing is the noise transmission MEDIUM. Depending on whether the monobloc bell-housing is a rigid or low noise type, there will be variations in the flexible properties of the transmission medium. The acoustic phenomena are dissimilar in the two cases, given the differences in pressure variation and particle displacement.

MOTOR AND PUMP UNIT

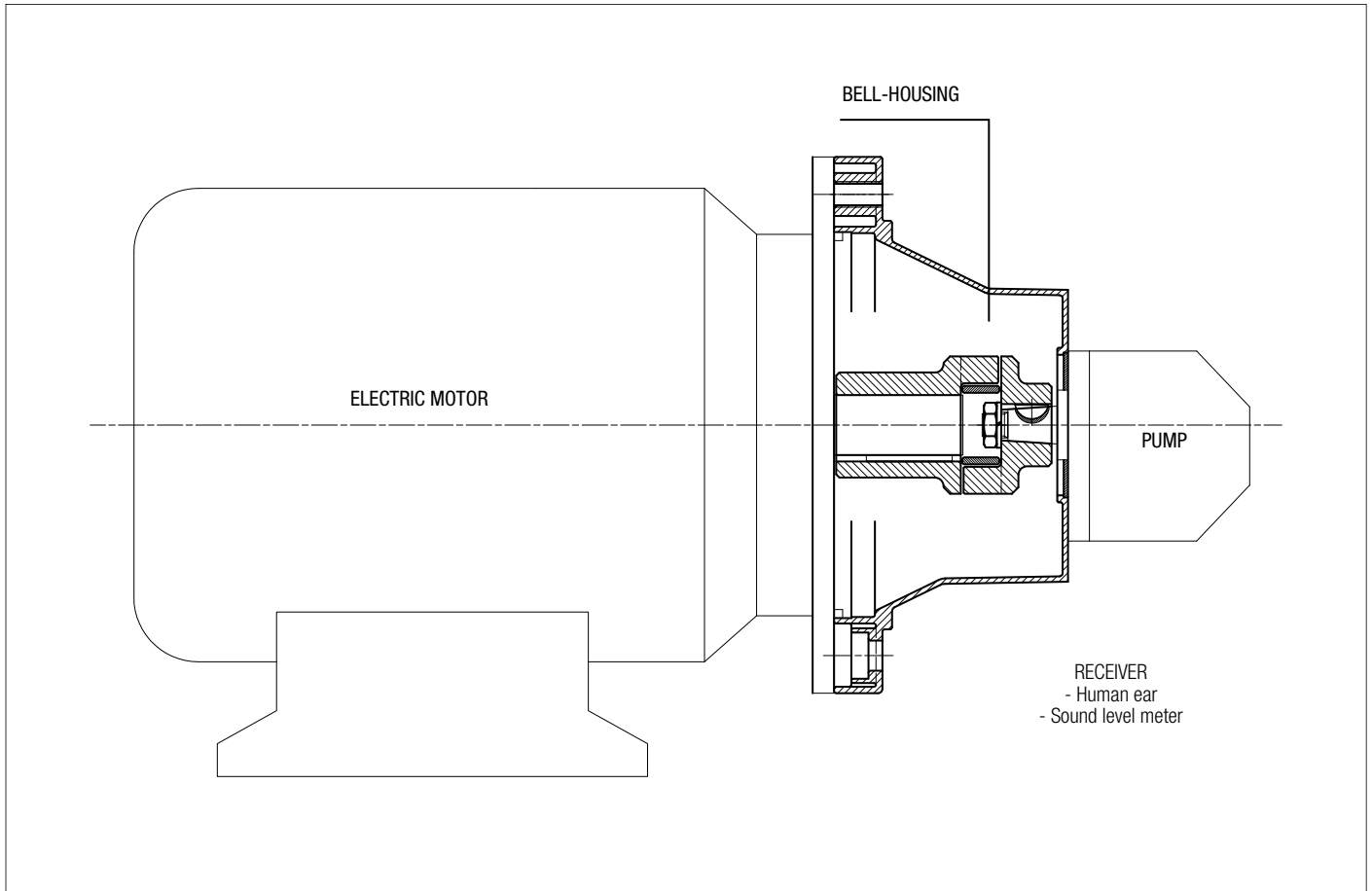

Low noise bell-housing will help to attenuate the transmission of vibrations and the emission of noise generated by the system.

Self-evidently, however, the mere adoption of a low noise bell-housing will achieve little unless the motor and pump are correctly installed on the machine or on the tank of the hydraulic power unit.

Should be followed in order to achieve best possible results and correct installation:

① MOTOR AND PUMP UNIT MOUNTED HORIZONTALLY ON OIL TANK LID

- The suction pipe attached to the pump must be rigid and fitted using a resilient bulkhead flange of the FTA series, which helps to cushion the vibrations propagated between the pipe and the tank lid.
If pipes need to be bent, the radius of curvature must be at least 3 times the pipe diameter.
Do not use elbow fittings, as these will significantly increase pressure losses.
- The pressure pipeline of the pump must be flexible and long enough to include bends with the minimum radius of curvature recommended by the manufacturer for the specified operating pressure.
- The return pipeline running from the service to the filter must be flexible.
Where oil is returned directly to the tank of the hydraulic power unit through a rigid pipe, it is advisable to use a resilient bulkhead flange of the FTR series, which helps to cushion the vibrations propagated between the pipe and the tank lid.
- Anti-vibration devices (resilient mounts or damping rods) must be located under the feet of the electric motor or the PDM foot brackets, depending on the mounting position of the motor.
- The lids of hydraulic oil tanks must be sturdy enough to support the load they carry.

② MOTOR AND PUMP UNIT MOUNTED HORIZONTALLY ON MACHINE

- As a matter of good practice, the oil tank and motor-pump unit should be mounted on a single supporting frame of strength sufficient to support the load.
- If the hydraulic system is fitted with a side-mounted filter, the suction pipeline to the pump must be flexible and long enough to include bends with the minimum radius of curvature recommended by the manufacturer.
- If the suction filter is not side mounted, the pipeline should be rigid and installed in conjunction with a compensating coupling.
- The pressure pipeline of the pump must be flexible, and long enough to include bends with the minimum radius of curvature recommended by the manufacturer for the specified operating pressure.
- The return pipeline running from the service to the filter must be flexible.
Where oil is returned directly to the tank of the hydraulic power unit through a rigid pipe, it is advisable to use a resilient bulkhead flange of the FTR series, which helps to cushion the vibrations propagated between the pipe and the tank lid.
- Anti-vibration devices (resilient mounts or damping rods) must be located under the feet of the electric motor or the PDM foot brackets, depending on the mounting position of the motor.

FINAL CONSIDERATION

For best results, in any event, the motor-and-pump unit should be incorporated into the hydraulic system in such a way that no one component is rigidly associated with another, resulting in the propagation of vibration, and consequently noise.

RECOMMENDED TIGHTENING TORQUES FOR MOTOR/PUMP FIXING ON THE BELL-HOUSING

M6	10 N·m	M16	205 N·m
M8	15 N·m	M18	280 N·m
M10	50 N·m	M20	400 N·m
M12	84 N·m	M22	530 N·m
M14	135 N·m	M24	690 N·m

Note: The above guidelines are indicative only and subordinate to the solutions adopted ultimately by design engineers.

**Valid configuration
for bell-housing up to Ø400**

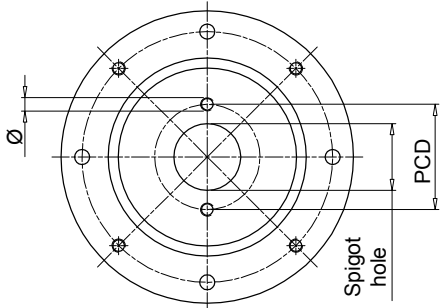

Bell-housing with nr. 2 holes at pump interface, aligned with through holes at motor interface.

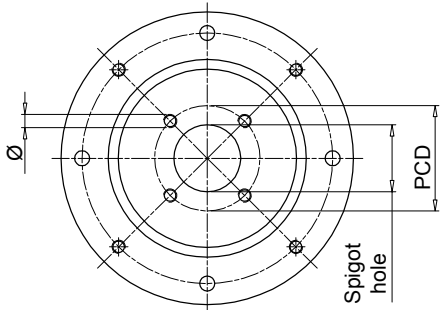

Bell-housing with nr. 4 holes at pump interface, aligned with thread holes at motor interface.

**Valid configuration for bell-housing
from Ø450 to Ø660**

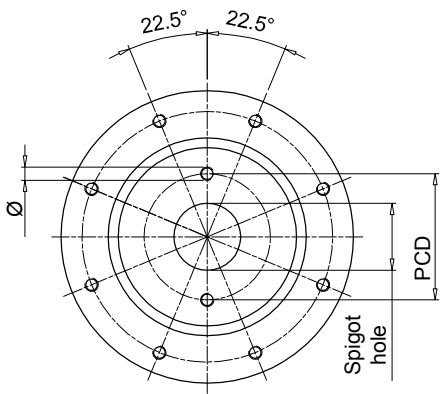

Bell-housing with nr. 2 holes at pump interface + 22.5° compared to through holes at motor interface.

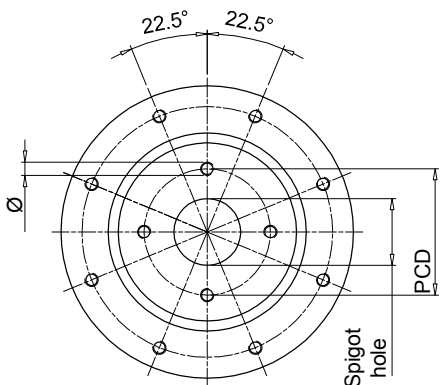

Bell-housing with nr. 4 holes at pump interface + 22.5° compared to thread holes at motor interface.

Spigot hole [mm]	PCD	Ø	Nr. holes	Code	Type
40	72.00	M8	2	191	-
45.2	88.90	M8	4	096	-
	71.80	M8	4	120	-
50	80.00	M8	2	052	ISO3019-2-50-B2
	93.00	M10	2	053	-
	60.00	M5	4	280	-
	63.00	Ø7	4	057	-
50.8	93.00	M8	2	287	-
	82.50	M8	2	050	SAE A-A 50-2
56	76.00	M6	4	234	-
57.15	106.40	Ø11	2	212	-
60	74.00	M10	4	098	-
	98.50	M6	4	147	-
62.7	75.00	M6	4	227	-
	157.20	M12	4	231	-
63	100.00	M8	2	042	ISO3019-2-63-B2
	125.00	M6	4	043	-
	85.00	M8	4	044	-
	80.00	M8	2	051	-
	80.00	Ø8.5	4	058	-
	100.00	M10	2	062	-
	82.00	M8	4	168	ISO3019-2-63-B4
	90.00	M8	4	271	-
65	90.00	M8	4	073	-
70	84.00	Ø7	4	289	-
71.8	88.90	M10	4	047	-
75	102.00	M10	4	139	-
	100.00	M8	4	024	ISO3019-2-80-B4
	103.20	M8	2	045	ISO3019-2-80-B2
	100.00	Ø11	4	059	-
	100.00	M10	2	061	-
	110.00	M10	2	063	-
	140.00	M10	2	064	-
	115.00	M10	2	065	-
	100.00	M10	4	067	-
	106.40	M10	2	083	-
	130.00	M8	4	087	-
100.00	Ø8.5	4	093	-	
113.00	M12	4	104	-	
95.00	M8	4	169	-	
103.00	M8	4	242	-	
110.00	M10	4	272	-	
80	106.40	M10	2	060	SAE A 82-2
	105.00	M10	4	097	-
	106.40	M8	2	254	-
	146.00	M12	2	260	-
82.55	110.00	M10	2	284	-
	106.40	M10	2	066	-
85	112.00	M8	2	134	-
	105.00	M8	4	156	-
	118.00	Ø9	2	163	-
90	112.00	Ø9	2	164	-
	140.00	M8	4	088	-
92	145.00	M10	4	089	-

"-": configuration out of ISO & SAE Standard

Spigot hole [mm]	PCD	Ø	Nr. holes	Code	Type
95	115.00	M8	4	137	-
	127.00	M10	4	131	-
98.4	125.00	Ø11	4	128	-
100	125.00	M10	2	023	ISO3019-2-100-B4
	125.00	M10	4	025	ISO3019-2-100-B2
	125.00	Ø11	4	031	-
	125.00	M5	4	032	-
	190.00	Ø15	4	038	-
	125.00	Ø13	4	041	-
	125.00	M12	2	071	-
	140.00	M12	2	072	-
	146.00	M12	2	075	-
	126.00	M10	2	106	-
	120.00	M8	4	122	-
	160.00	M10	4	141	-
150.00	M10	4	150	-	
101.6	161.50	M12	4	029	-
	146.00	M12	2	070	SAE B 101-2
	127.00	M12	4	125	-
	146.00	M10	2	159	-
105	127.00	M10	4	224	-
	146.00	M12	2	076	-
110	175.00	M10	4	110	-
	130.00	M8	4	154	-
	200.00	M10	4	202	-
	135.00	M10	4	219	-
	145.00	M12	4	273	-
112	140.00	M12	2	074	-
	140.00	M10	2	138	-
	130.00	M10	4	264	-
115	180.00	M12	4	198	-
116	160.00	M14	2	084	-
120	210.00	M16	2	094	-
	145.00	M10	4	155	-
	150.00	Ø13	4	267	-
125	160.00	M12	4	026	ISO3019-2-125-B4
	160.00	Ø13	4	033	-
	160.00	M12	2	079	-
	180.00	M16	2	082	ISO3019-2-125-B2
	155.00	M10	4	102	-
	160.00	Ø17	4	113	-
	200.00	M12	4	114	-
	181.20	M16	2	136	-
	200.00	M16	4	200	-
	180.00	Ø20	4	215	-
	170.00	Ø18	4	237	-
127	161.50	M12	4	021	-
	181.20	M16	2	080	SAE C 127-2
	161.50	M14	4	140	-
130	165.00	Ø11	4	054	-
	150.00	M12	4	068	-
	181.20	M16	2	085	-
	165.00	M12	4	124	-
	165.00	M14	4	135	-

"-": configuration out of ISO & SAE Standard

Spigot hole [mm]	PCD	Ø	Nr. holes	Code	Type
130	165.00	M10	4	253	-
135	160.00	M10	4	151	-
	175.40	M12	4	220	-
140	180.00	M14	4	077	ISO3019-2-140-B4
	180.00	M12	2	081	-
	165.00	M10	4	157	-
	200.00	M16	4	176	ISO3019-2-140-B2
	165.00	Ø11	4	223	-
	180.00	M16	2	232	-
150	185.00	M16	4	069	-
	228.60	M16	4	022	-
152.4	228.60	M18	2	090	-
	228.60	M18	4	108	-
	217.50	Ø17	4	118	-
	228.60	M20	2	166	SAE D 152-2
	228.60	M20	4	192	SAE D 152 -4
	190.50	M8	4	207	-
160	200.00	M16	4	027	ISO3019 - 2 -160 B4
	200.00	Ø17	4	035	-
	200.00	M16	2	091	-
	224.00	M20	2	092	ISO3019 - 2 -160 B2
	200.00	M12	2	107	-
	230.00	M22	4	111	-
	185.00	M12	4	152	-
	224.00	M16	4	184	-
230.00	Ø22	4	228	-	
162	188.00	M12	4	263	-
165.1	317.35	M20	4	143	SAE E 165 - 4
	317.35	M24	2	145	SAE E 165 - 2
	229.00	M20	4	201	-
175	317.35	M18	4	204	-
	200.00	M12	4	153	-
177.8	230.00	M18	2	185	-
	350.00	M24	4	146	SAE F 177 - 4
180	216.00	M12	4	222	-
	350.00	M24	2	203	SAE F 177 - 2
	216.00	Ø13	4	055	-
	216.00	M16	4	078	-
	224.00	M16	4	112	ISO3019 - 2 -180 B4
	216.00	M12	4	132	-
200	215.00	M22	4	148	-
	230.00	M22	4	226	-
	250.00	M20	4	028	ISO3019 - 2 -200 B4
	250.00	Ø22	4	095	-
	280.00	M24	2	117	-
	230.50	M12	4	214	-
203.2	254.00	M14	4	210	-
205	240.00	M16	4	133	-
224	280.00	M20	4	144	ISO3019 - 2 -224 B4
	280.00	Ø22	4	205	-
250	310.00	M24	4	238	-
	315.00	M20	4	282	ISO3019 - 2 -250 B4
275	355.00	M16	4	233	-
	355.00	Ø18	4	281	-

"-": configuration out of ISO & SAE Standard

LMG series

IEC electric motor range from size 63 up to size 225



Technical data

Bell-Housing - IEC electric motor range from size 63 up to size 225

Materials

- Bell-housing: Pressure die casting Aluminium
- Center ring: Galvanized Steel
- Gasket: Special paper - Guarnital

Compatibility with fluids

Modular bell-housing components compatible for use with:

- Mineral oils types HH-HL-HM-HR-HV, to ISO 6743/4 standard
- Water based emulsions types HFAE-HFAS, to ISO 6743/4 standard
- Water glycol type HFC, to ISO 6743/4 standard: ask for anodized version

Special Applications

Any applications not covered by the normal indications contained in this catalogue must be evaluated and approved by MP Filtri Technical and Sales Department

Temperature

From -30 °C to +80 °C

Note

For temperatures outside this range, contact MP Filtri Technical and Sales Department



IEC Electric motors

Bell-Housing size	European standard size						German standard size			IEC Motors size
	0.5	1	2	3	3.5	4	ZB	ZF	ZG	
LMG140	●	●	●				●			IEC 63 Ø140 - Ø11x23
LMG160	●	●	●				●			IEC 71 Ø160 - Ø14x30
LMG200	●	●	●	●			●	●		IEC 80 Ø200 - Ø19x40
LMG200	●	●	●	●			●	●		IEC 90 Ø200 - Ø24x50
LMG250		●	●	●	●		●	●		IEC 110 Ø250 - Ø28x60
LMG250		●	●	●	●		●	●		IEC 112 Ø250 - Ø28x60
LMG300		●	●	●	●	●	●	●	●	IEC 132 Ø300 - Ø38x80
LMG351			●	●	●	●	●	●	●	IEC 160 Ø350 - Ø42x110
LMG351			●	●	●	●	●	●	●	IEC 180 Ø350 - Ø48x110
LMG400			●	●	●	●	●	●	●	IEC 200 Ø400 - Ø55x110
LMG450			●	●	●	●	●	●	●	IEC 225 Ø450 - Ø60x140

Note: For specific information see pages 70 ÷ 72 "Table of Combination"

LMG * 4S**

Without centre ring allowing removal of half-coupling (which as a rule is keyed permanently to the pump shaft); motor mounting flange drilled with 4 clearance holes + 4 threaded holes. Used normally for vertically mounted motor and pump units with pump submerged in the oil tank.

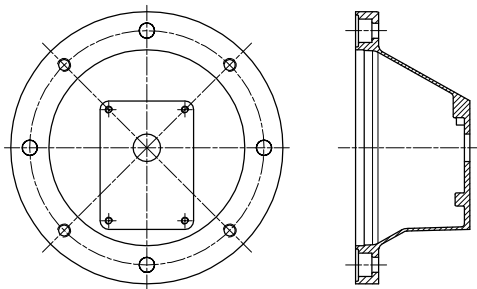

LMG * 4E**

With centre ring allowing removal of half-coupling (which as a rule is keyed permanently to the pump shaft), motor mounting flange drilled with 4 clearance holes + 4 threaded holes. Normally used for motor and pump units mounted horizontally on the tank lid or on the machine for maximum ease of maintenance. With this type of mounting, in effect, the hydraulic pump can be removed without removing the motor. The half-coupling mounted to the shaft passes through the spigot hole.

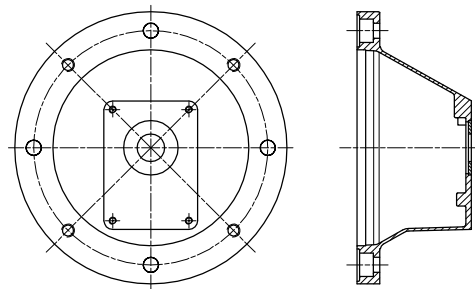

LMG * 8S**

Without centre ring allowing removal of half-coupling (which as a rule is keyed permanently to the pump shaft), motor mounting flange drilled with 8 clearance holes. Used normally for vertically mounted motor and pump units with pump submerged in the oil tank, allows greater flexibility for directional positioning of the hydraulic pump inside the tank, according to constructional requirements.

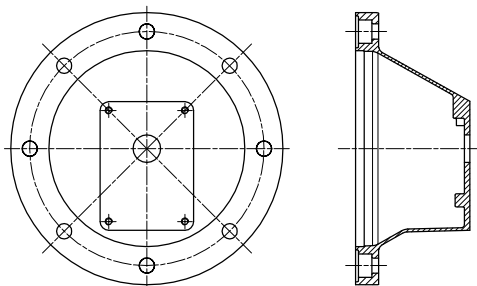

LMG * 8E**

With centre ring allowing removal of half-coupling (which as a rule is keyed permanently to the pump shaft), motor mounting flange drilled with 8 clearance holes. Normally used for motor and pump units mounted horizontally on the tank lid or on the machine, offers maximum ease of maintenance and enables directional positioning of the pump. With this type of mounting, in effect, the hydraulic pump can be removed without removing the motor. The half-coupling mounted to the shaft passes through the spigot hole.

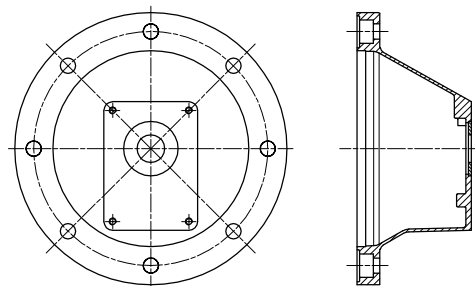

Designation & Ordering code

COMPLETE KIT (BELL-HOUSING & COUPLINGS)

Motors identification code				Configuration example: AKA02 FS200 Z 4E			
Size		Size		Size			
02	63 B3-B5	13	180 B3-B5	44	71 B14		
03	71 B3-B5	16	200 B3-B5	45	80 B14		
04	80 B3-B5	18	225 B3-B5	46	90 B14		
05	90 B3-B5	20	250 B3-B5	48	100/112 B14		
07	100/112 B3-B5	22	280 B3-B5				
11	132 B3-B5	26	315 B3-B5				
12	160 B3-B5	43	63 B14				

Pump flange identification code
FS200 See page 67

Product revision code
Z

Versions

4S	4 through holes + 4 threaded holes, motor interface without coupling removal ring
4E	4 through holes + 4 threaded holes, motor interface with coupling removal ring
8S	8 through holes, motor interface without coupling removal ring
8E	8 through holes, motor interface with coupling removal ring

BELL-HOUSING LMG

Bell-Housing series and size				Configuration example: LMG140 M FS200 4E DI				
LMG140	LMG200	LMG300	LMG550					
LMG141	LMG201	LMG351	LMG660					
LMG160	LMG250	LMG400						
LMG161	LMG251	LMG450						

Product revision code
M

Pump flange identification code
FS200 See page 67

Versions

4S	4 through holes + 4 threaded holes, motor interface without coupling removal ring
4E	4 through holes + 4 threaded holes, motor interface with coupling removal ring
8S	8 through holes, motor interface without coupling removal ring
8E	8 through holes, motor interface with coupling removal ring

Options

DI	Drain hole + inspection hole
AN	Black anodized finish
SA	Motor interface with clearance holes
Pxx	Customer specification

COUPLING KIT

Motors identification code		Configuration example: AKG02 FS200 Z		
Size	Size			
02	63 B3-B5	13	180 B3-B5	
03	71 B3-B5	43	63 B14	
04	80 B3-B5	44	71 B14	
05	90 B3-B5	45	80 B14	
07	100/112 B3-B5	46	90 B14	
11	132 B3-B5	48	100/112 B14	
12	160 B3-B5			

Pumps flange identification code
FS200 See page 67

Product revision code
Z

Note:

- Bell-Housings with DI options are supplied complete with threaded closure plug.
- Bell-Housing with 4E/8E version are supplied with center ring mounted.
- For product range codes see pages 70 ÷ 72

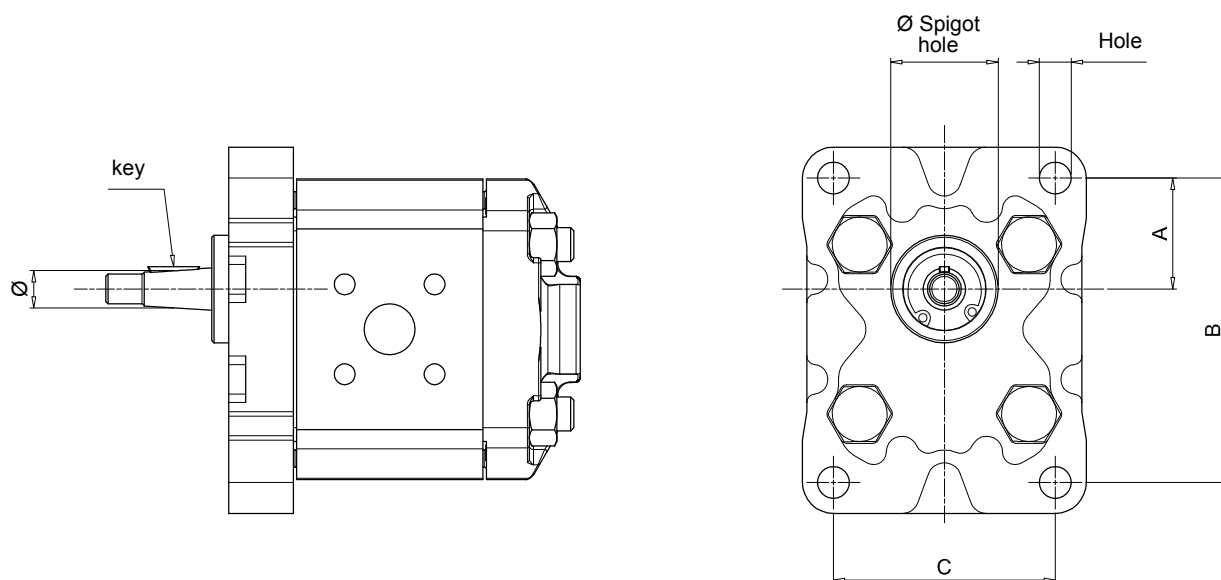

Designation of pump flange and shaft

Pump group	Ø Spigot hole	Dimensions				Pump flange code	Ø	Key	Shaft type	Pump half-coupling code
		A	B	C	Hole					
05	22.0	25.5	66.0	-	M6	FS05M	6.0	2.0	parallel	FS05M
	22.0	25.5	66.0	-	M6	FS05C	7.0	2.0	parallel	FS05C
1	25.4	26.2	72.0	52.0	M6	FS100	9.7	2.4	tapered 1:8	FS100
	30.0	24.5	73.0	56.0	M6	FS1M0	12.0	3.0	parallel	FS1C0
	30.0	24.5	73.0	56.0	M6	FS1M0	13.9	3.0	tapered 1:8	FS1M0
2	36.5	32.5	96.0	71.5	M8	FS200	17.2	3.2 - 4	tapered 1:8	FS200
	50.8	43.0	128.0	98.5	M8	FS25T	22.2	4.0	tapered 1:8	FS300
3	50.8	42.0	128.0	98.5	M10	FS300	22.2	4.0	tapered 1:8	FS300
	50.8	43.0	128.0	98.5	M10	FS3M0	22.2	4.0	tapered 1:8	FS300
	50.8	45.0	137.0	98.5	M10	FS3T0	22.2	4.0	tapered 1:8	FS300
	60.0	48.5	148.0	127.0	M12	FS35M	25.6	4.76 - 5.0	tapered 1:8	FS350
3.5	60.3	49.5	149.5	114.3	M10	FS350	25.6	4.76 - 5.0	tapered 1:8	FS350
	63.5	65.0	196.0	142.8	M12	FS4M0	33.3	6.35 - 7.0	tapered 1:8	FS400
4	63.5	64.3	188.0	143.0	M12	FS400	33.3	6.35 - 7.0	tapered 1:8	FS400
	32.0	10.3	40.0	40.0	M8	FSZBR	9.8	2.0	tapered 1:5	FSZBR
Bosch	80.0	34.5	100.0	72.0	M8	FSZFR	16.9	3.0	tapered 1:5	FSZFR
	105.0	48.0	145.0	102.0	M10	FSZGR	25.2	5.0	tapered 1:5	FSZGR

Inspection Hole
Plastic threaded plug mounted
(protection according
to DIN EN 292 part 2)
"Safety of machines"

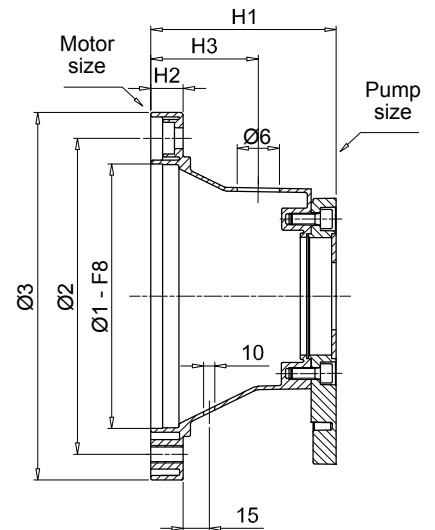
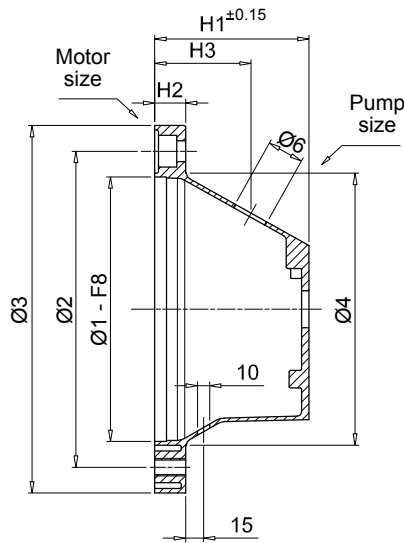
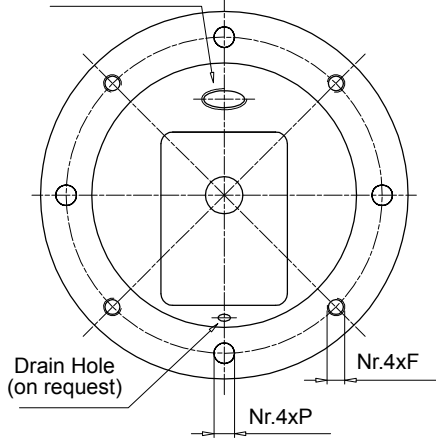

(*) Shape valid for LMG 251

Bell-housing

IEC - Electric motors		Bell-housing code	Dimensions [mm]								On request		Weight [kg]
Motor size	Shaft end [Ø x L]		Ø1	Ø1	Ø3	Ø4	H1	H2	F	P	H3	Ø6	
63 - B14	11x23	LMG090	60	75	90	63	60	7	-	6	40	1/2"	0.30
71 - B14	14x30	LMG105	70	85	105	74	67	8	-	7	40	1/2"	0.35
80 - B14	19x40	LMG120	80	100	120	84	87	9	-	7	45	1/2"	0.40
63 - B3/B5	11x23	LMG140	95	115	140	100	60	13	M8	9	40	1/2"	0.35
63 - B3/B5	11x23	LMG141	95	115	140	100	95	13	M8	9	50	1/2"	0.40
71 - B3/B5	14x30	LMG160	110	130	160	110	70	15	M8	9	40	1/2"	0.44
71 - B3/B5	14x30	LMG161	110	130	160	110	105	15	M8	9	50	1/2"	0.50
80 - B3/B5	19x40	LMG200	130	165	200	135	87	18	M10	11	45	3/4"	0.68
90 - B3/B5	24x50	LMG201	130	165	200	135	95	18	M10	11	50	3/4"	0.80
100-112 - B3/B5	28x60	LMG250	180	215	250	185	105	22	M12	14	70	3/4"	1.16
100-112 - B3/B5	28x60	LMG251 (*)	180	215	250	185	126	22	M12	14	70	3/4"	1.80

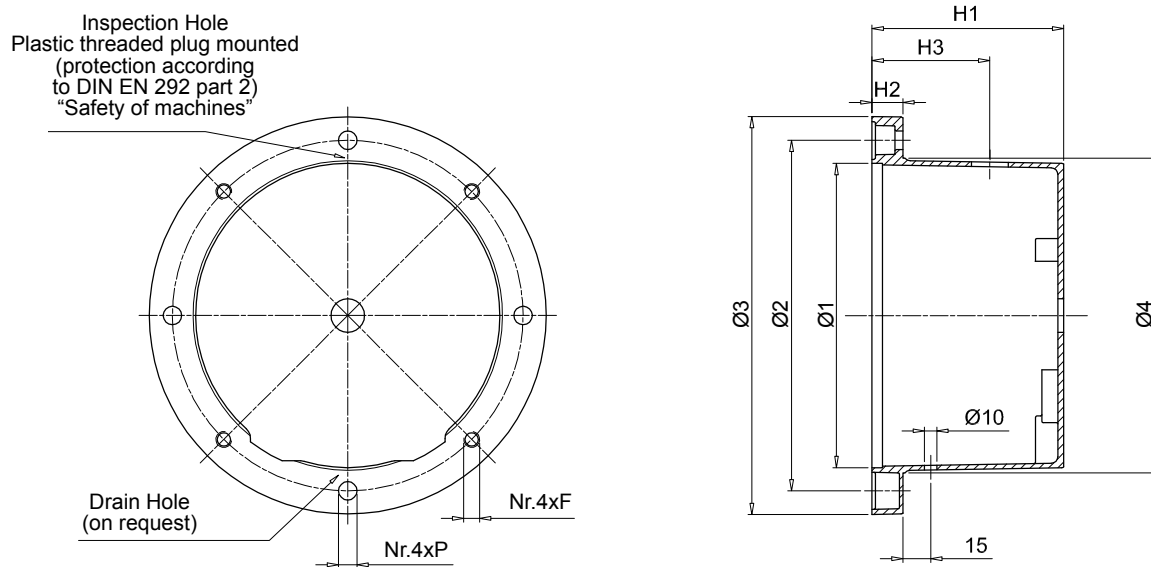

Bell-housing

IEC - Electric motors		Bell-housing code	Dimensions [mm]								On request		Weight [kg]
Motor size	Shaft end [Ø x L]		Ø1	Ø2	Ø3	Ø4	H1	H2	F	P	H3	Ø6	
132	38x80	LMG300	230	265	300	235	145	23	M12	14	80	1"	2.55
160	42x110	LMG351	250	300	350	255	178	31	M16	18	100	1"	4.90
180	48x110	LMG351	250	300	350	255	178	31	M16	18	100	1"	4.90

IEC Motors B3/5 - standard gear pump

IEC - Electric motors Motor size	Shaft end [Ø x L]	Pump identification code	Components					
			Bell-Housing code	Motor half-coupling code	Spider code	Pump half-coupling code	Complete kit code	Complete coupling kit code
63	11x23	FS05M	LMG140MFS05M4S	SGEA01M01019	EGE 0	SGEA01FS05M	AKA02FS05MZ4S	AKG02FS05MZ
		FS05C	LMG140MFS05M4S			SGEA01FS05C	AKA02FS05CZ4S	AKG02FS05CZ
		FS100	LMG140MFS1004S/4E			SGEA01FS100	AKA02FS100Z4S/4E	AKG02FS100Z
		FS1C0	LMG140MFS1M04S/4E			SGEA01FS1C0	AKA02FS1C0Z4S/4E	AKG02FS1C0Z
		FS1M0	LMG140MFS1M04S/4E			SGEA01FS1M0	AKA02FS1M0Z4S/4E	AKG02FS1M0Z
		FSZBR	LMG140MFSZBR4S			SGEA01FSZBR	AKA02FSZBRZ4S	AKG02FSZBRZ
71	14x30	FS05M	LMG160MFS05M4S	SGEA01M02028	EGE 0	SGEA01FS05M	AKA03FS05MZ4S	AKG03FS05MZ
		FS05C	LMG160MFS05M4S			SGEA01FS05C	AKA03FS05CZ4S	AKG03FS05CZ
		FS100	LMG160MFS1004S/4E			SGEA01FS100	AKA03FS100Z4S/4E	AKG03FS100Z
		FS1C0	LMG160MFS1M04S/4E			SGEA01FS1C0	AKA03FS1C0Z4S/4E	AKG03FS1C0Z
		FS1M0	LMG160MFS1M04S/4E			SGEA01FS1M0	AKA03FS1M0Z4S/4E	AKG03FS1M0Z
		FSZBR	LMG160MFSZBR4S			SGEA01FSZBR	AKA03FSZBRZ4S	AKG03FSZBRZ
80	19x40	FS05M	LMG200MFS05M4S	SGEA01M03048	EGE 0	SGEA01FS05M	AKA04FS05MZ4S	AKG04FS05MZ
		FS05C	LMG200MFS05M4S			SGEA01FS05C	AKA04FS05CZ4S	AKG04FS05CZ
		FS100	LMG200MFS1004S/4E			SGEA01FS100	AKA04FS100Z4S/4E	AKG04FS100Z
		FS1C0	LMG200MFS1M04S/4E			SGEA01FS1C0	AKA04FS1C0Z4S/4E	AKG04FS1C0Z
		FS1M0	LMG200MFS1M04S/4E			SGEA01FS1M0	AKA04FS1M0Z4S/4E	AKG04FS1M0Z
		FSZBR	LMG200MFSZBR4S			SGEA01FSZBR	AKA04FSZBRZ4S	AKG04FSZBRZ
		FS200	LMG201MFS2004S/4E	SGEA21M03048	EGE 2	SGEA21FS200	AKA04FS200Z4S/4E	AKG04FS200Z
		FSZFR	LMG201MFSZFR4S			SGEA21FSZFR	AKA04FSZFRZ4S	AKG04FSZFRZ
90	24x50	FS05M	LMG200MFS05M4S	SGEA01M04048	EGE 0	SGEA01FS05M	AKA05FS05MZ4S	AKG05FS05MZ
		FS05C	LMG200MFS05M4S			SGEA01FS05C	AKA05FS05CZ4S	AKG05FS05CZ
		FS100	LMG200MFS1004S/4E			SGEA01FS100	AKA05FS100Z4S/4E	AKG05FS100Z
		FS1C0	LMG200MFS1M04S/4E			SGEA01FS1C0	AKA05FS1C0Z4S/4E	AKG05FS1C0Z
		FS1M0	LMG200MFS1M04S/4E			SGEA01FS1M0	AKA05FS1M0Z4S/4E	AKG05FS1M0Z
		FSZBR	LMG200MFSZBR4S			SGEA01FSZBR	AKA05FSZBRZ4S	AKG05FSZBRZ
		FS200	LMG201MFS2004S/4E	SGEA21M04048	EGE 2	SGEA21FS200	AKA05FS200Z4S/4E	AKG05FS200Z
		FSZFR	LMG201MFSZFR4S			SGEA21FSZFR	AKA05FSZFRZ4S	AKG05FSZFRZ
100 112	28x60	FS100	LMG250MFS1004S	SGEA21M05055	EGE 2	SGEA21FS100	AKA07FS100Z4S	AKG07FS100Z
		FS1C0	LMG250MFS1M04S			SGEA21FS1C0	AKA07FS1C0Z4S	AKG07FS1C0Z
		FS1M0	LMG250MFS1M04S			SGEA21FS1M0	AKA07FS1M0Z4S	AKG07FS1M0Z
		FSZBR	LMG250MFSZBR4S			SGEA21FSZBR	AKA07FSZBRZ4S	AKG07FSZBRZ
		FS200	LMG250MFS2004S/4E			SGEA21FS200	AKA07FS200Z4S/4E	AKG07FS200Z
		FSZFR	LMG250MFSZFR4S			SGEA21FSZFR	AKA07FSZFRZ4S	AKG07FSZFRZ
		FS25T	LMG251MFS25T4E			SGEA21FS300	AKA07FS25TZ4E	AKG07FS300Z
		FS300	LMG251MFS3004E			SGEA21FS300	AKA07FS300Z4E	AKG07FS300Z
		FS3M0	LMG251MFS3M04E			SGEA21FS300	AKA07FS3M0Z4E	AKG07FS300Z
FS3T0	LMG251MFS3T04E	SGEA21FS300	AKA07FS3T0Z4E	AKG07FS300Z				
132	38x80	FS100	LMG300MFS1004S	SGEA31M06077	EGE 3	SGEA31FS100	AKA11FS100Z4S	AKG11FS100Z
		FS1C0	LMG300MFS1M04S			SGEA31FS1C0	AKA11FS1C0Z4S	AKG11FS1C0Z
		FS1M0	LMG300MFS1M04S			SGEA31FS1M0	AKA11FS1M0Z4S	AKG11FS1M0Z
		FSZGR	LMG300MFSZGR4S			SGEA31FSZGR	AKA11FSZGRZ4S	AKG11FSZGRZ
		FS200	LMG300MFS2004S/4E			SGEA31FS200	AKA11FS200Z4S/4E	AKG11FS200Z
		FSZFR	LMG300MFSZFR4S			SGEA31FSZFR	AKA11FSZFRZ4S	AKG11FSZFRZ
		FS25T	LMG300MFS25T4S/4E			SGEA31FS300	AKA11FS25TZ4S/4E	AKG11FS300Z
		FS300	LMG300MFS3004S/4E			SGEA31FS300	AKA11FS300Z4S/4E	AKG11FS300Z
		FS3M0	LMG300MFS3M04S/4E			SGEA31FS300	AKA11FS3M0Z4S/4E	AKG11FS300Z
		FS3T0	LMG300MFS3T04S/4E			SGEA31FS300	AKA11FS3T0Z4S/4E	AKG11FS300Z
		FS35M	LMG300MFS35M4S/4E			SGEA31FS350	AKA11FS35MZ4S/4E	AKG11FS350Z
		FS350	LMG300MFS3504S/4E			SGEA31FS350	AKA11FS350Z4S/4E	AKG11FS350Z

Note:

- For bell-housing dimensions see pages 68-69.
- For coupling dimensions see "Half-couplings" section on pages 30-31.

IEC Motors B3/5 - standard gear pump

IEC - Electric motors		Pump identification code	Components					
Motor size	Shaft end [Ø x L]		Bell-Housing code	Motor half-coupling code	Spider code	Pump half-coupling code	Complete kit code	Complete coupling kit code
160	42x110	FSZGR	LMG351MFSZGR4S	SGEA51M07109	EGE 5	SGEA51FSZGR	AKA12FSZGRZ4S	AKG12FSZGRZ
		FS200	LMG351MFS2004S			SGEA51FS200	AKA12FS200Z4S	AKG12FS200Z
		FSZFR	LMG351MFSZFR4S			SGEA51FSZFR	AKA12FSZFRZ4S	AKG12FSZFRZ
		FS25T	LMG351MFS25T4S/4E			SGEA51FS300	AKA12FS25TZ4S/4E	AKG12FS300Z
		FS300	LMG351MFS3004S/4E			SGEA51FS300	AKA12FS300Z4S/4E	AKG12FS300Z
		FS3M0	LMG351MFS3M04S/4E			SGEA51FS300	AKA12FS3M0Z4S/4E	AKG12FS300Z
		FS3T0	LMG351MFS3T04S/4E			SGEA51FS300	AKA12FS3T0Z4S/4E	AKG12FS300Z
		FS35M	LMG351MFS35M4S/4E			SGEA51FS350	AKA12FS35MZ4S/4E	AKG12FS350Z
		FS350	LMG351MFS3504S/4E			SGEA51FS350	AKA12FS350Z4S/4E	AKG12FS350Z
180	48x110	FSZGR	LMG351MFSZGR4S	SGEA51M08109	EGE 5	SGEA51FSZGR	AKA13FSZGRZ4S	AKG13FSZGRZ
		FS200	LMG351MFS2004S			SGEA51FS200	AKA13FS200Z4S	AKG13FS200Z
		FSZFR	LMG351MFSZFR4S			SGEA51FSZFR	AKA13FSZFRZ4S	AKG13FSZFRZ
		FS25T	LMG351MFS25T4S/4E			SGEA51FS300	AKA13FS25TZ4S/4E	AKG13FS300Z
		FS300	LMG351MFS3004S/4E			SGEA51FS300	AKA13FS300Z4S/4E	AKG13FS300Z
		FS3M0	LMG351MFS3M04S/4E			SGEA51FS300	AKA13FS3M0Z4S/4E	AKG13FS300Z
		FS3T0	LMG351MFS3T04S/4E			SGEA51FS300	AKA13FS3T0Z4S/4E	AKG13FS300Z
		FS35M	LMG351MFS35M4S/4E			SGEA51FS350	AKA13FS35MZ4S/4E	AKG13FS350Z
		FS350	LMG351MFS3504S/4E			SGEA51FS350	AKA13FS350Z4S/4E	AKG13FS350Z
200	55x110	FS200	LMG400MFS2004E	SGEA51M09109	EGE 5	SGEA51FS200	AKA16FS200Z4S	AKG16FS200Z
		FS300	LMG400MFS3004E			SGEA51FS300	AKA16FS300Z4E	AKG16FS300Z
		FS3M0	LMG400MFS3M04E			SGEA51FS300	AKA16FS3M0Z4E	AKG16FS300Z
		FS35M	LMG400MFS35M4E			SGEA51FS350	AKA16FS35MZ4E	AKG16FS350Z
		FS350	LMG400MFS3504E			SGEA51FS350	AKA16FS350Z4E	AKG16FS350Z
		FSZFR	LMG400MFSZFR4S			SGEA51FSZFR	AKA16FSZFRZ4E	AKG16FSZFRZ
		FSZGR	LMG400MFSZGR4S			SGEA51FSZGR	AKA16FSZGRZ4E	AKG16FSZGRZ
225	60x140	FS300	LMG450MFS3004E	SGEG60M10110	EGE 6	SGEG60FS300	AKA18FS300Z4E	AKG18FS300Z
		FS3M0	LMG450MFS3M04E			SGEG60FS300	AKA18FS3M0Z4E	AKG18FS300Z
		FS35M	LMG450MFS35M4E			SGEG60FS350	AKA18FS35MZ4E	AKG18FS350Z
		FS350	LMG450MFS3504E			SGEG60FS350	AKA18FS350Z4E	AKG18FS350Z
		FSZGR	LMG450MFSZGR4S			SGEG60FSZGR	AKA18FSZGRZ4E	AKG18FSZGRZ
250	65x140	FS300	LMG550MFS3004E	SGEG60M11140	EGE 6	SGEG60FS300	AKA20FS300Z4E	AKG20FS300Z
		FS3M0	LMG550MFS3M04E			SGEG60FS300	AKA20FS3M0Z4E	AKG20FS300Z
		FS35M	LMG550MFS35M4E			SGEG60FS350	AKA20FS35MZ4E	AKG20FS350Z
		FS350	LMG550MFS3504E			SGEG60FS350	AKA20FS350Z4E	AKG20FS350Z
		FSZGR	LMG550MFSZGR4S			SGEG60FSZGR	AKA20FSZGRZ4E	AKG20FSZGRZ
280	75x140	FS300	LMG550MFS3004E	SGEG80M12140	EGE 8	SGEG80FS300	AKA22FS300Z4E	AKG22FS300Z
		FS3M0	LMG550MFS3M04E			SGEG80FS300	AKA22FS3M0Z4E	AKG22FS300Z
		FS35M	LMG550MFS35M4E			SGEG80FS350	AKA22FS35MZ4E	AKG22FS350Z
		FS350	LMG550MFS3504E			SGEG80FS350	AKA22FS350Z4E	AKG22FS350Z
		FSZGR	LMG550MFSZGR4S			SGEG80FSZGR	AKA22FSZGRZ4E	AKG22FSZGRZ
315	80x170	FS300	LMG660MFS3004E	SGEG80M13170	EGE 8	SGEG80FS300	AKA26FS300Z4E	AKG26FS300Z
		FS3M0	LMG660MFS3M04E			SGEG80FS300	AKA26FS3M0Z4E	AKG26FS300Z
		FS35M	LMG660MFS35M4E			SGEG80FS350	AKA26FS35MZ4E	AKG26FS350Z
		FS350	LMG660MFS3504E			SGEG80FS350	AKA26FS350Z4E	AKG26FS350Z
		FSZGR	LMG660MFSZGR4S			SGEG80FSZGR	AKA26FSZGRZ4E	AKG26FSZGRZ

Note:

- For bell-housing dimensions see pages 68-69.
- For coupling dimensions see "Half-couplings" section on pages 30-31.

IEC Electric motors B14 mounting

IEC - Electric motors		Pump identification code	Components							
Motor size	Shaft end [Ø x L]		Bell-Housing code	Motor half-coupling code	Spider code	Pump half-coupling code	Complete kit code	Complete coupling kit code		
63	11x23	FS05M	LMG090MFS05M4E	SGEA01M01019	EGE0	SGEA00FS05M	AKA43FS05MZ4E	AKG43FS05MZ		
		FS05C	LMG090MFS05M4E			SGEA01FS05C	AKA43FS05CZ4E	AKG43FS05CZ		
		FS100	LMG090MFS1004E			SGEA01FS100	AKA43FS100Z4E	AKG43FS100Z		
		FS1C0	LMG090MFS1M04E			SGEA01FS1C0	AKA43FS1C0Z4E	AKG43FS1C0Z		
		FS1M0	LMG090MFS1M04E			SGEA01FS1M0	AKA43FS1M0Z4E	AKG43FS1M0Z		
		FSZBR	LMG090MFSZBR4E			SGEA01FSZBR	AKA43FSZBRZ4E	AKG43FSZBRZ		
71	14x30	FS05M	LMG105MFS05M4E	SGEA01M02028	EGE 0	SGEA01FS05M	AKA44FS05MZ4E	AKG44FS05MZ		
		FS05C	LMG105MFS05M4E			SGEA01FS05C	AKA44FS05CZ4E	AKG44FS05CZ		
		FS100	LMG105MFS1004E			SGEA01FS100	AKA44FS100Z4E	AKG44FS100Z		
		FS1C0	LMG105MFS1C04E			SGEA01FS1C0	AKA44FS1C0Z4E	AKG44FS1C0Z		
		FS1M0	LMG105MFS1M04E			SGEA01FS1M0	AKA44FS1M0Z4E	AKG44FS1M0Z		
		FSZBR	LMG105MFSZBR4E			SGEA01FSZBR	AKA44FSZBRZ4E	AKG44FSZBRZ		
80	19x40	FS05M	LMG120MFS05M4E	SGEA01M03048	EGE 0	SGEA01FS05M	AKA45FS05MZ4E	AKG45FS05MZ		
		FS05C	LMG120MFS05M4E			SGEA01FS05C	AKA45FS05CZ4E	AKG45FS05CZ		
		FS100	LMG120MFS1004E			SGEA01FS100	AKA45FS100Z4E	AKG45FS100Z		
		FS1C0	LMG120MFS1M04E			SGEA01FS1C0	AKA45FS1C0Z4E	AKG45FS1C0Z		
		FS1M0	LMG120MFS1M04E			SGEA01FS1M0	AKA45FS1M0Z4E	AKG45FS1M0Z		
		FSZBR	LMG120MFSZBR4S			SGEA01FSZBR	AKA45FSZBRZ4E	AKG45FSZBRZ		
		FS200	LMG121MFS2004E	SGEA21M03048	EGE 2	SGEA21FS200	AKA45FS200Z4E	AKG45FS200Z		
		FSZFR	LMG121MFSZFR4S			SGEA21FSZFR	AKA45FSZFRZ4S	AKG45FSZFRZ		
90	24x50	FS05M	LMG141MFS05M4S	SGEA01M04048	EGE 0	SGEA01FS05M	AKA46FS05MZ4E	AKG46FS05MZ		
		FS05C	LMG141MFS05M4S			SGEA01FS05C	AKA46FS05CZ4E	AKG46FS05CZ		
		FS100	LMG141MFS1004S/4E			SGEA01FS100	AKA46FS100Z4E	AKG46FS100Z		
		FS1C0	LMG141MFS1M04S/4E			SGEA01FS1C0	AKA46FS1C0Z4E	AKG46FS1C0Z		
		FS1M0	LMG141MFS1M04S/4E			SGEA01FS1M0	AKA46FS1M0Z4E	AKG46FS1M0Z		
		FSZBR	LMG141MFSZBR4S			SGEA01FSZBR	AKA46FSZBRZ4E	AKG46FSZBRZ		
		FS200	LMG141MFS2004S/4E	SGEA21M04048	EGE 2	SGEA21FS200	AKA46FS200Z4E	AKG46FS200Z		
		FSZFR	LMG141MFSZFR4S			SGEA21FSZFR	AKA46FSZFRZ4S	AKG46FSZFRZ		
100 112	28x60	FS05M	LMG161MFS05M4S	SGEA21M05055	EGE 2	SGEA21FS05M	AKA48FS05MZ4E	AKG48FS05MZ		
		FS05C	LMG161MFS05M4S			SGEA21FS05C	AKA48FS05CZ4E	AKG48FS05CZ		
		FS100	LMG161MFS1004S			SGEA21FS100	AKA48FS100Z4E	AKG48FS100Z		
		FS1C0	LMG161MFS1M04S			SGEA21FS1C0	AKA48FS1C0Z4E	AKG48FS1C0Z		
		FS1M0	LMG161MFS1M04S			SGEA21FS1M0	AKA48FS1M0Z4E	AKG48FS1M0Z		
		FSZBR	LMG161MFSZBR4S			SGEA21FSZBR	AKA48FSZBRZ4E	AKG48FSZBRZ		
		FS200	LMG161MFS2004S/4E			SGEA21M05055	EGE 2	SGEA21FS200	AKA48FS200Z4E	AKG48FS200Z
		FSZFR	LMG161MFSZFR4S					SGEA21FSZFR	AKA48FSZFRZ4S	AKG48FSZFRZ

Note:

- For bell-housing dimensions see pages 68-69.
- For coupling dimensions see "Half-couplings" section on pages 30-31.

CENTER RING

Center ring code	Dimensions [mm]		
	Ø1	Ø2	Thk.
ANC01FS100	50	25.4	1.0
ANC01FS1M0	50	30.0	1.0
ANC02FS200	72	36.5	2.0
ANC03FS200	88	36.5	2.0
ANC03FS300	88	50.8	2.5
ANC03FS350	88	60.3	2.5
ANC04FS300	115	50.8	3.5
ANC04FS350	115	60.3	3.5
ANCA001	42	22.0	1.0
ANCD005	85	50.8	2.5

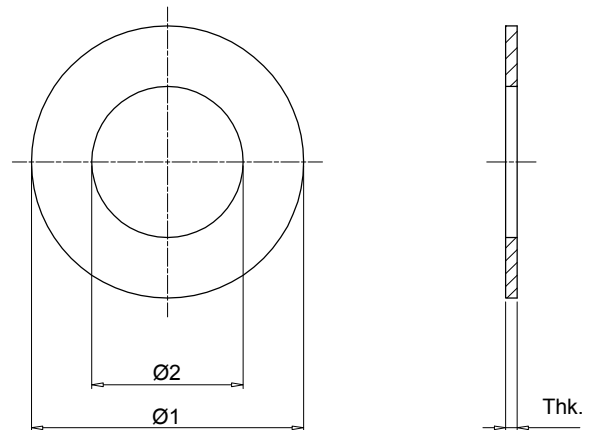

Center ring code	Bell-Housing size										
	LMG090	LMG105	LMG120	LMG140	LMG160	LMG200	LMG250	LMG300	LMG351	LMG400	LMG450
ANC01FS100	●	●	●	●	●						
ANC01FSM0	●	●	●	●	●						
ANC02FS200			●	●	●	●	●				
ANC03FS200								●	●		
ANC03FS300								●			
ANC03FS350								●			
ANC04FS200										●	●
ANC04FS300									●	●	●
ANC04FS350									●	●	●
ANCA001	●	●	●	●	●		●				
ANCD005						●	●	●	●		

GASKET

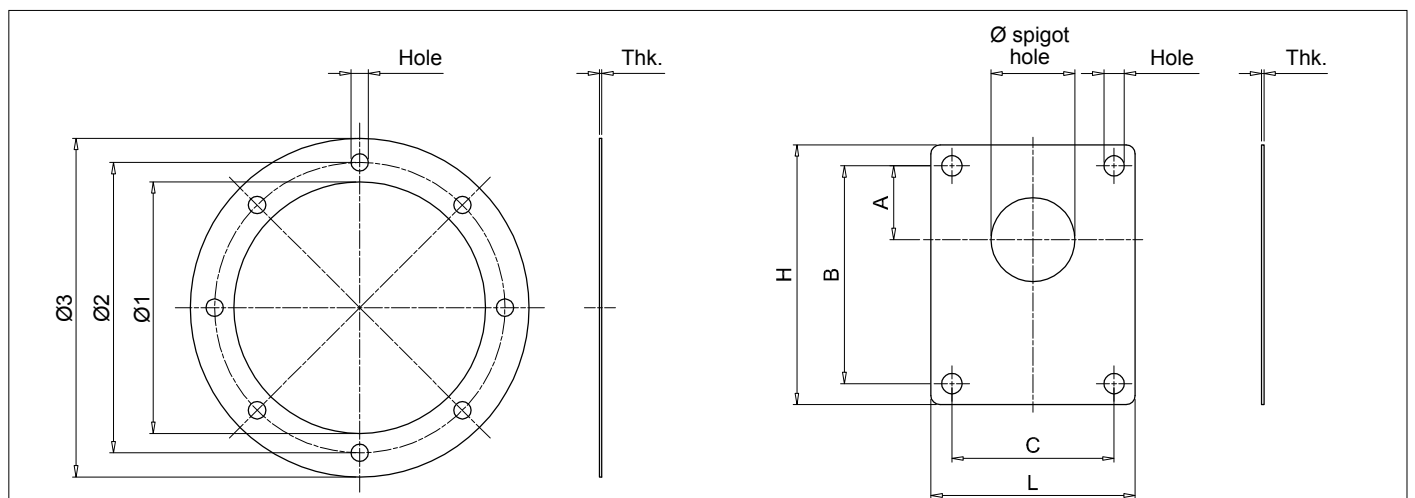

Motor side gasket

Bell-housing size	Seals code	Dimensions [mm]				
		Ø1	Ø2	Ø3	Thk.	Hole
LMG 120	GUM P 120	84	100	120	1	7
LMG 140	GUM P 140	96	115	140	1	9
LMG 160	GUM P 160	110	130	160	1	9
LMG 200	GUM P 200	145	165	200	1	11
LMG 250	GUM P 250	190	215	250	1	14
LMG 300	GUM P 300	234	265	300	1	14
LMG 350	GUM P 350	260	300	350	1	18

Pump side gasket

Pump identification code	Seals code	Dimensions [mm]							
		Ø	A	B	C	H	L	Thk.	Hole
FS05M	GUP P001	22.0	25.6	66	-	80	48	1	6.5
FS100	GUP P002	25.4	26.6	72	52.4	87	67	1	6.5
FS1M0	GUP P003	30.0	24.5	73	56.0	85	68	1	6.5
FS200	GUP P004	36.5	32.5	96	71.5	112	88	1	8.5
FS300	GUP P005	50.8	43.0	128	98.5	148	118	1	10.5
FSZBR	GUP P013	32.0	10.35	40	40.0	75	62	1	8.5
FSZFR	GUP P014	80.0	34.5	100	72.0	118	90	1	9.0

LMC/LDC series

IEC electric motor range from size 80 up to size 355



Technical data

Bell-Housing - IEC electric motor range from size 80 up to size 355

Materials

- Monobloc bell-housing: Pressure die-cast aluminium alloy
- Pump flange: Pressure die-cast aluminium alloy
- Screws kit: Steel
- Gaskets: Special paper (Guarnital)
- Plug for inspection: Polyamide

Compatibility with fluids

Modular bell-housing components compatible for use with:

- Mineral oils types HH-HL-HM-HR-HV, to ISO 6743/4 standard
- Water based emulsions types HFAE-HFAS, to ISO 6743/4 standard
- Water glycol type HFC, to ISO 6743/4 standard: ask for anodized version

Special Applications

Any applications not covered by the normal indications contained in this catalogue must be evaluated and approved by MP Filtri Technical and Sales Department

Temperature

From -30 °C to +80 °C

Note

For temperatures outside this range, contact MP Filtri Technical and Sales Department



Range

Bell-Housing size	Flange ISO 3019-2								IEC Motors size
	50 B2-B4	63 B2-B4	80 B2-B4	100 B2-B4	125 B2-B4	160 B2-B4	200 B2-B4		
LMC200	●	●	●	●					IEC 80 Ø200 - Ø19x40
LMC200	●	●	●	●					IEC 90 Ø200 - Ø24x50
LMC250	●	●	●	●	●				IEC 100 Ø250 - Ø28x60
LMC250	●	●	●	●	●				IEC 112 Ø250 - Ø28x60
LMC300			●	●	●	●			IEC 132 Ø300 - Ø38x80
LMC350			●	●	●	●			IEC 160 Ø350 - Ø42x110
LMC350			●	●	●	●	●		IEC 180 Ø350 - Ø48x110
LMC400			●	●	●	●	●		IEC 200 Ø400 - Ø55x110
LMC450			●	●	●	●	●		IEC 225 Ø450 - Ø60x140
LMC550					●	●	●		IEC 250 Ø550 - Ø65x140
LMC550					●	●	●		IEC 280 Ø550 - Ø75x140
LMC660					●	●	●		IEC 315 Ø660 - Ø80x170

Bell-Housing size	Flange SAE J 744										IEC Motors size	
	50-2 (A-A)	82-2 (A)	101-2 (B)	127-2 (C)	152-2 (D)	165-2 (E)	101-4 (B)	127-4 (D)	152-4 (D)	165-4 (E)		
LMC200	●	●										IEC 80 Ø200 - Ø19x40
LMC200	●	●										IEC 90 Ø200 - Ø24x50
LMC250	●	●	●				●					IEC 100 Ø250 - Ø28x60
LMC250	●	●	●	●			●					IEC 112 Ø250 - Ø28x60
LMC300		●	●	●			●	●				IEC 132 Ø300 - Ø38x80
LMC350		●	●	●			●	●				IEC 160 Ø350 - Ø42x110
LMC350		●	●	●	●		●	●	●			IEC 180 Ø350 - Ø48x110
LMC400		●	●	●	●	●	●	●	●	●		IEC 200 Ø400 - Ø55x110
LMC450			●	●	●	●		●	●	●		IEC 225 Ø450 - Ø60x140
LMC550				●	●	●		●	●	●		IEC 250 Ø550 - Ø65x140
LMC550				●	●	●		●	●	●		IEC 280 Ø550 - Ø75x140
LMC660				●	●	●		●	●	●		IEC 315 Ø660 - Ø80x170

Designation & Ordering code

LMC

Bell-Housing series and size

LMC200AFSJ	LMC350AFSU
LMC200AFSW	LMC400AFSV
LMC250AFSM	LMC450AFSZ
LMC250AFSQ	LMC550AFSN
LMC250AFSR	LMC550AFSO
LMC300AFST	LMC660AFSP
LMC300AFSX	LMC660AFSS
LMC350AFSY	

Configuration example: **LMC200AFSJ** **070** **DI**

Pump interface codes

070 See page 60

Options

DI	Drain hole + inspection hole
FR	Holes rotated through 45° in relation to standard position
DP	Double set of hole
AN	Black anodized finish
SA	Clearance holes at motor interface
Pxx	Customer specification

LDC

Bell-Housing series and size

LDC200AFRB	LDC350AF6B
LDC200AFRC	LDC400AF5A
LDC200AFRD	LDC400AF5B
LDC250AFRC	LDC400AF6A
LDC300AFRC	LDC400AF6B
LDC300AF5A	LDC450AF6A
LDC300AF5B	LDC450AF6B
LDC350AF6A	

Configuration example: **LDC200AFRB** **070** **DI**

Pump interface codes

070 See page 60

Options

DI	Drain hole + inspection hole
FR	Holes rotated through 45° in relation to standard position
DP	Double set of hole
AN	Black anodized finish
SA	Clearance holes at motor interface
Pxx	Customer specification

Note:

- Bell-housings with DI options are supplied complete with threaded closure plug.
- For customization features other than those indicated on this page, contact MP Filtri Technical and Sales Department.

Inspection Hole
Plastic threaded plug mounted
(protection according to DIN EN 292 part 2)
"Safety of machines"

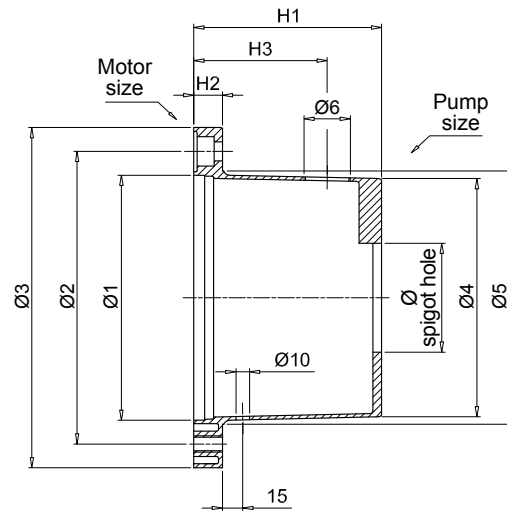
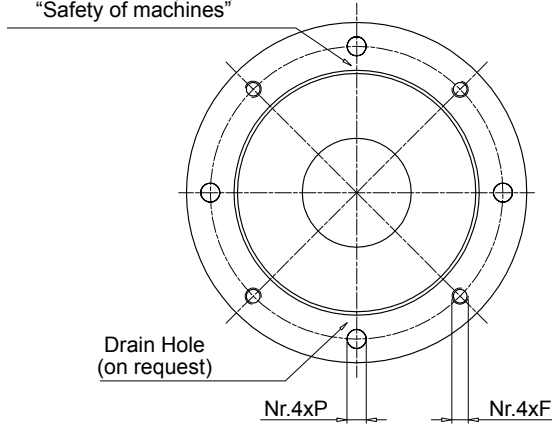

IEC - Electric motors		Bell-housing code	Dimensions [mm]									On request		Ø spigot hole Minimum [mm]	Weight [kg]
Motor size	Shaft end [Ø x L]		Ø1	Ø2	Ø3	Ø4	Ø5	H1	H2	F	P	H3	Ø6		
80	19x40	LMC200AFSJ***	130	165	200	125	135	100	18	M10	11	60	3/4"	50	0.75
90	24x50	LMC200AFSW***	130	165	200	125	135	125	18	M10	11	85	3/4"	50	0.95
110 - 112	28x60	LMC250AFSM***	180	215	250	175	186	114	19	M12	14	75	3/4"	50	1.50
		LMC250AFSQ***	180	215	250	175	186	138	19	M12	14	100	3/4"	50	1.60
		LMC250AFSR***	180	215	250	175	186	159	19	M12	14	120	3/4"	50	1.75
132	38x80	LMC300AFST***	230	265	300	230	235	155	23	M12	14	80	3/4"	80	3.20
		LMC300AFSX***	230	265	300	230	235	170	23	M12	14	95	3/4"	80	3.30
160	42x110	LMC350AFSY***	250	300	350	240	254	178	31	M16	18	95	1"	50	4.80
180	48x110	LMC350AFSU***	250	300	350	240	254	194	31	M16	18	115	1"	80	4.90
200	55x110	LMC400AFSV***	300	350	400	280	305	201	31	M16	18	125	1 1/2"	80	6.50

Inspection Hole
Plastic threaded plug mounted
(protection according to DIN EN 292 part 2)
"Safety of machines"

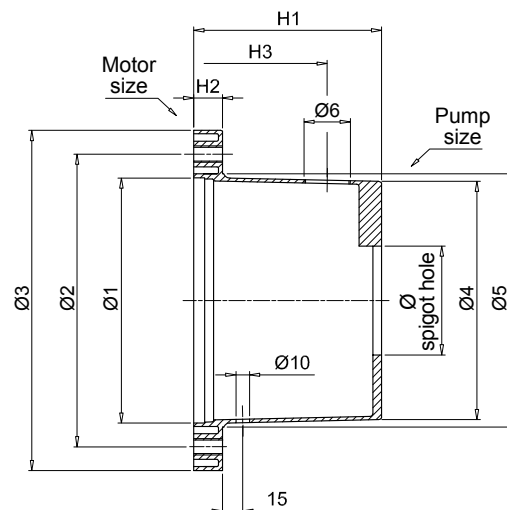
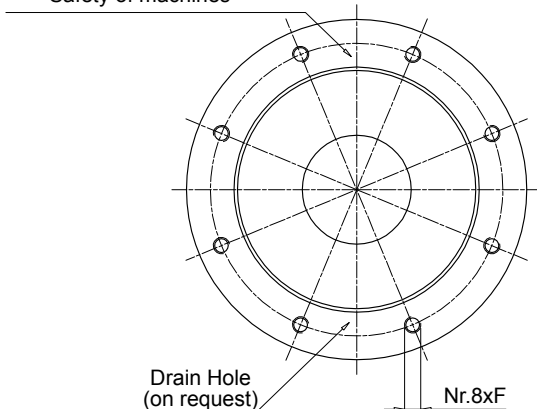

IEC - Electric motors		Bell-housing code	Dimensions [mm]									On request		Ø spigot hole Minimum [mm]	Weight [kg]
Motor size	Shaft end [Ø x L]		Ø1	Ø2	Ø3	Ø4	Ø5	H1	H2	F	P	H3	Ø6		
225	60x140	LMC450AFSZ***	350	400	450	320	350	250	31	M16	-	175	1 1/2"	80	9.00
250	65x140	LMC550AFSN***	450	500	550	-	-	265	31	M16	-	175	1 1/2"	100	15.00
280	75x140	LMC550AFSO***	450	500	550	-	-	310	35	M16	-	175	1 1/2"	100	17.00
315	80x170	LMC660AFSP***	550	600	660	-	-	295	45	M20	-	175	1 1/2"	100	27.00
		LMC660AFSS***	550	600	660	-	-	325	45	M20	-	175	1 1/2"	100	31.00

Dimensions

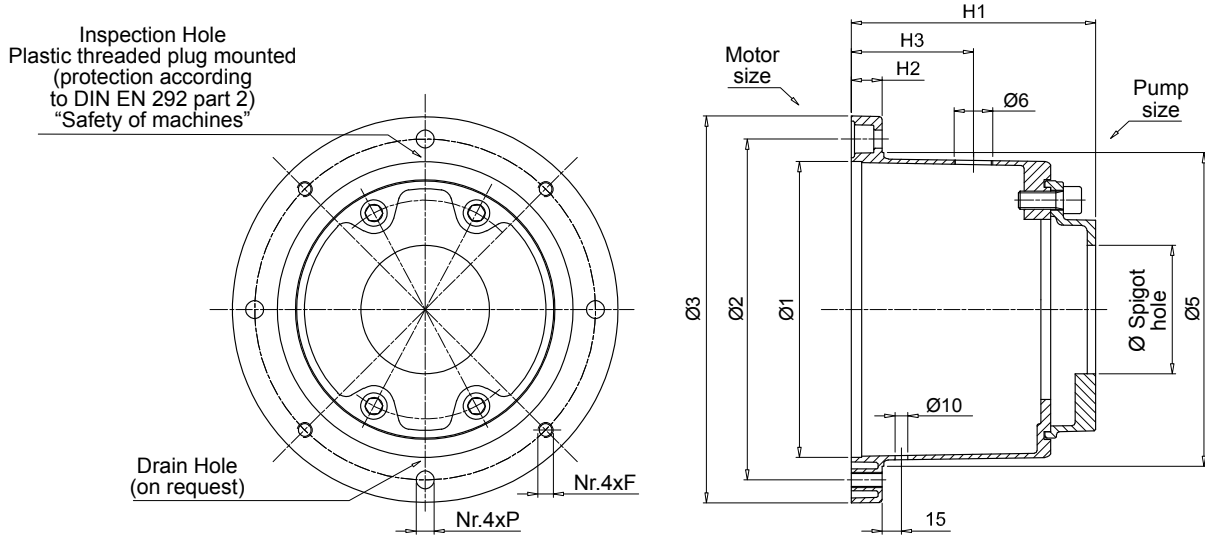

IEC - Electric motors		Bell-housing code	Dimensions [mm]								On request		Ø spigot hole Minimum [mm]	Weight [kg]
Motor size	Shaft end [Ø x L]		Ø1	Ø2	Ø3	Ø5	H1	H2	F	P	H3	Ø6		
80	19x40	LDC200AFRB***	130	165	200	135	125	18	M10	11	60	3/4"	50	1.85
90	24x50	LDC200AFRC***	130	165	200	135	133	18	M10	11	60	3/4"	50	1.95
		LDC200AFRD***	130	165	200	135	158	18	M10	11	75	3/4"	50	2.10
110 - 112	28x60	LDC250AFRC***	180	215	250	186	169	19	M12	14	100	3/4"	50	2.75
		LDC300AFRC***	230	265	300	235	185	23	M12	14	95	3/4"	50	4.60
132	38x80	LDC300AF5A***	230	265	300	235	190	23	M12	14	95	3/4"	80	4.50
		LDC300AF5B***	230	265	300	235	181	23	M12	14	95	3/4"	80	4.80
160	42x110	LDC350AF6A***	250	300	350	254	239	31	M16	18	115	1"	80	6.80
180	48x110	LDC350AF6B***	250	300	350	254	252	31	M16	18	115	1"	80	7.30
		LDC400AF5A***	300	350	400	305	246	31	M16	18	125	1 1/2"	80	7.50
200	55x110	LDC400AF5B***	300	350	400	305	234	31	M16	18	125	1 1/2"	80	7.90
		LDC400AF6A***	300	350	400	305	246	31	M16	18	125	1 1/2"	80	8.50
		LDC400AF6B***	300	350	400	305	260	31	M16	18	125	1 1/2"	80	9.00

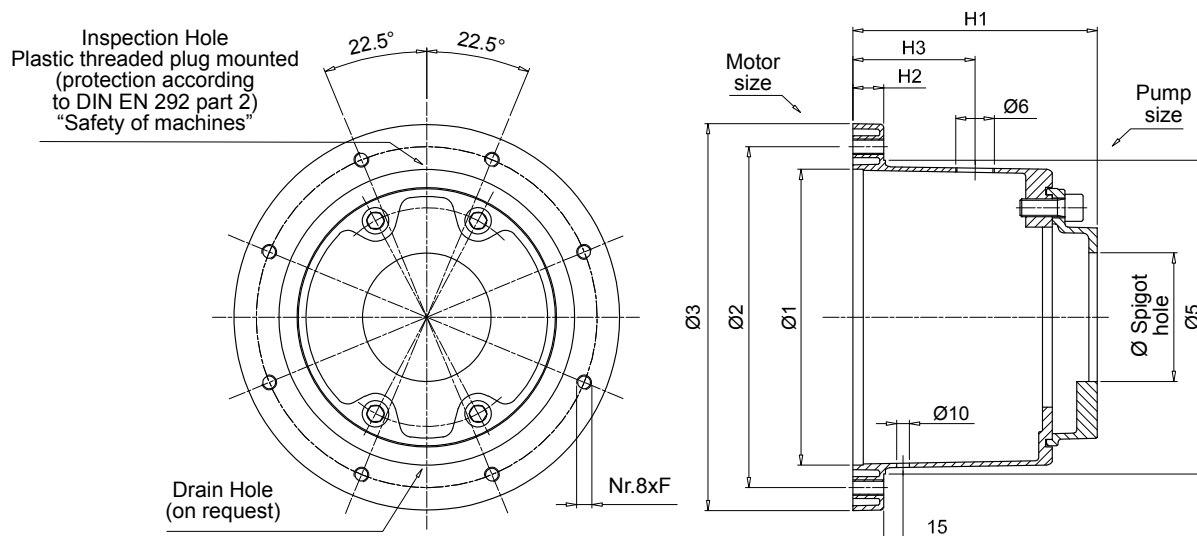

IEC - Electric motors		Bell-housing code	Dimensions [mm]							On request		Ø spigot hole Minimum [mm]	Weight [kg]	
Motor size	Shaft end [Ø x L]		Ø1	Ø2	Ø3	Ø5	H1	H2	F	P	H3			Ø6
225	60x140	LDC450AF6A***	350	400	450	350	295	31	M16	-	175	1 1/2"	80	11.20
		LDC450AF6B***	350	400	450	350	308	31	M16	-	175	1 1/2"	80	11.60

Comparative table

MP Filtri code	KTR code	OMT code	Raja code	Hydrapp code
LMC200A***	PK200/3/...	TH20A***	R200/99-115/...	-
LMC200A***	PL200/8/...	TH1***	R200/120-135/...	HLC1
LMC250A***	PL250/6/...	TH2***	R250/120-135/...	HLC3
LMC300A***	PL300/4/...	TH3***	R300/155-170/...	HLC5
LMC350A***	PK350/4/...	TH4***	R350/173-194/...	HLC8
LMC400A***	PK400/4/...	TH15***	R400/194-210/...	HLC12
LMC450A***	PK450/4/...	TH18***	R450/250-210/...	-
LMC550A***	PK550/4/...	TH19***	R550/250-210/...	-
LMC660A***	PK660/4/...	TH20***	R660/250-210/...	-

Note:

The above table is guideline only.
Not all bell-housings are fully interchangeable.

LMS/LDS series

IEC electric motor range from size 100 up to size 315



Technical data

Bell-Housing - IEC electric motor range from size 100 up to size 315

Materials

- Motor base bell-housing: Pressure die-cast aluminium alloy
- Pump flange: Pressure die-cast aluminium alloy
- Internal ring: Pressure die-cast aluminium alloy
- Damping ring: Vulcanized aluminium + NBR 75 Shore A

Compatibility with fluids

Modular bell-housing components compatible for use with:

- Mineral oils types HH-HL-HM-HR-HV, to ISO 6743/4 standard
- Water based emulsions types HFAE-HFAS, to ISO 6743/4 standard
- Water glycol type HFC, to ISO 6743/4 standard: ask for anodized version

Special Applications

Any applications not covered by the normal indications contained in this catalogue must be evaluated and approved by MP Filtri Technical and Sales Department

Temperature

From -30 °C to +80 °C

Note

For temperatures outside this range, contact MP Filtri Technical and Sales Department



Range

Bell-Housing size	Flange ISO 3019-2							IEC Motors size
	50 B2-B4	63 B2-B4	80 B2-B4	100 B2-B4	125 B2-B4	160 B2-B4	200 B2-B4	
LMS250	●	●	●	●	●			IEC 100 Ø250 - Ø28x60
LMS250	●	●	●	●	●			IEC 112 Ø250 - Ø28x60
LMS300			●	●	●	●		IEC 132 Ø300 - Ø38x80
LMS350			●	●	●	●		IEC 160 Ø350 - Ø42x110
LMS350			●	●	●	●	●	IEC 180 Ø350 - Ø48x110
LMS400			●	●	●	●	●	IEC 200 Ø400 - Ø55x110
LMS450			●	●	●	●	●	IEC 225 Ø450 - Ø60x140
LMS550					●	●	●	IEC 250 Ø550 - Ø65x140
LMS550					●	●	●	IEC 280 Ø550 - Ø75x140
LMS660					●	●	●	IEC 315 Ø660 - Ø80x170

Bell-Housing size	Flange SAE J 744									IEC Motors size	
	50-2 (A-A)	82-2 (A)	101-2 (B)	127-2 (C)	152-2 (D)	165-2 (E)	101-4 (B)	127-4 (D)	152-4 (D)		165-4 (E)
LMS250	●	●	●				●				IEC 100 Ø250 - Ø28x60
LMS250	●	●	●	●			●				IEC 112 Ø250 - Ø28x60
LMS300		●	●	●			●	●			IEC 132 Ø300 - Ø38x80
LMS350		●	●	●			●	●			IEC 160 Ø350 - Ø42x110
LMS350		●	●	●	●		●	●	●		IEC 180 Ø350 - Ø48x110
LMS400		●	●	●	●	●	●	●	●	●	IEC 200 Ø400 - Ø55x110
LMS450			●	●	●	●		●	●	●	IEC 225 Ø450 - Ø60x140
LMS550				●	●	●		●	●	●	IEC 250 Ø550 - Ø65x140
LMS550				●	●	●		●	●	●	IEC 280 Ø550 - Ø75x140
LMS660				●	●	●		●	●	●	IEC 315 Ø660 - Ø80x170

LMS/LDS

Designation & Ordering code

LMS

Bell-Housing series and size

Configuration example: **LMS250AFSA** **070** **DI**

LMS250AFSA	LMS400AFSL
LMS250AFSB	LMS400AFSM
LMS300AFSC	LMS400AFSN
LMS300AFSD	LMS450AFSO
LMS300AFSE	LMS550AFSP
LMS350AFSF	LMS550AFSR
LMS350AFSG	LMS660AFST
LMS350AFSH	

Pump interface codes

070 See page 60

Options

DI	Drain hole + inspection hole
FR	Holes rotated through 45° in relation to standard position
DP	Double set of hole
AN	Black anodized finish
SA	Clearance holes at motor interface
Pxx	Customer specification

LDS

Bell-Housing series and size

Configuration example: **LDS250AFRA** **070** **DI**

LDS250AFRA	LDS450AF6A
LDS250AFBB	LDS550AF6A
LDS250AFRE	LDS660AF6A
LDS300AFRB	
LDS300AFRC	
LDS300AF5G	
LDS350AF5A	
LDS400AF6A	

Pump interface codes

070 See page 60

Options

DI	Drain hole + inspection hole
FR	Holes rotated through 45° in relation to standard position
DP	Double set of hole
AN	Black anodized finish
SA	Clearance holes at motor interface
Pxx	Customer specification

Note:

- Bell-housings with DI options are supplied complete with threaded closure plug.
- For customization features other than those indicated on this page, contact MP Filtri Technical and Sales Department.

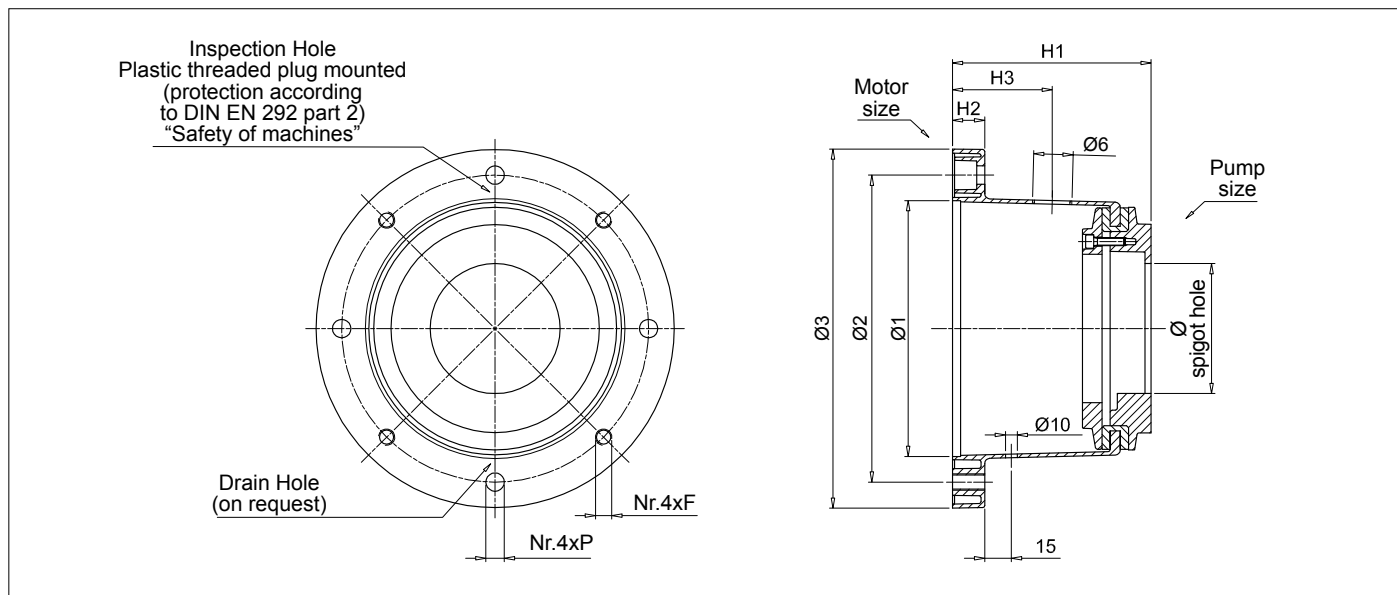

IEC - Electric motors		Bell-housing code	Dimensions [mm]							On request		Ø spigot hole Minimum [mm]	Weight [kg]
Motor size	Shaft end [Ø x L]		Ø1	Ø2	Ø3	H1	H2	F	P	H3	Ø6		
100 - 112	28x60	LMS250AFSA***	180	215	250	128	19	M12	14	75	3/4"	50	3.72
		LMS250AFSB***	180	215	250	148	19	M12	14	75	3/4"	50	4.10
132	38x80	LMS300AFSC***	230	265	300	155	23	M12	14	80	3/4"	50	4.20
		LMS300AFSD***	230	265	300	168	23	M12	14	80	3/4"	80	4.45
		LMS300AFSE***	230	265	300	194	23	M12	14	80	3/4"	80	6.51
160 180	42x110 48x110	LMS350AFSF***	250	300	350	204	31	M16	18	95	1"	80	6.80
		LMS350AFSG***	250	300	350	228	31	M16	18	95	1"	80	7.10
		LMS350AFSH***	250	300	350	204	31	M16	18	95	1"	80	8.51
200	55x110	LMS400AFSL***	300	350	400	228	31	M16	18	125	1 1/2"	80	8.80
		LMS400AFSM***	300	350	400	256	31	M16	18	125	1 1/2"	80	9.10
		LMS400AFSN***	300	350	400	240	31	M16	18	125	1 1/2"	80	11.61

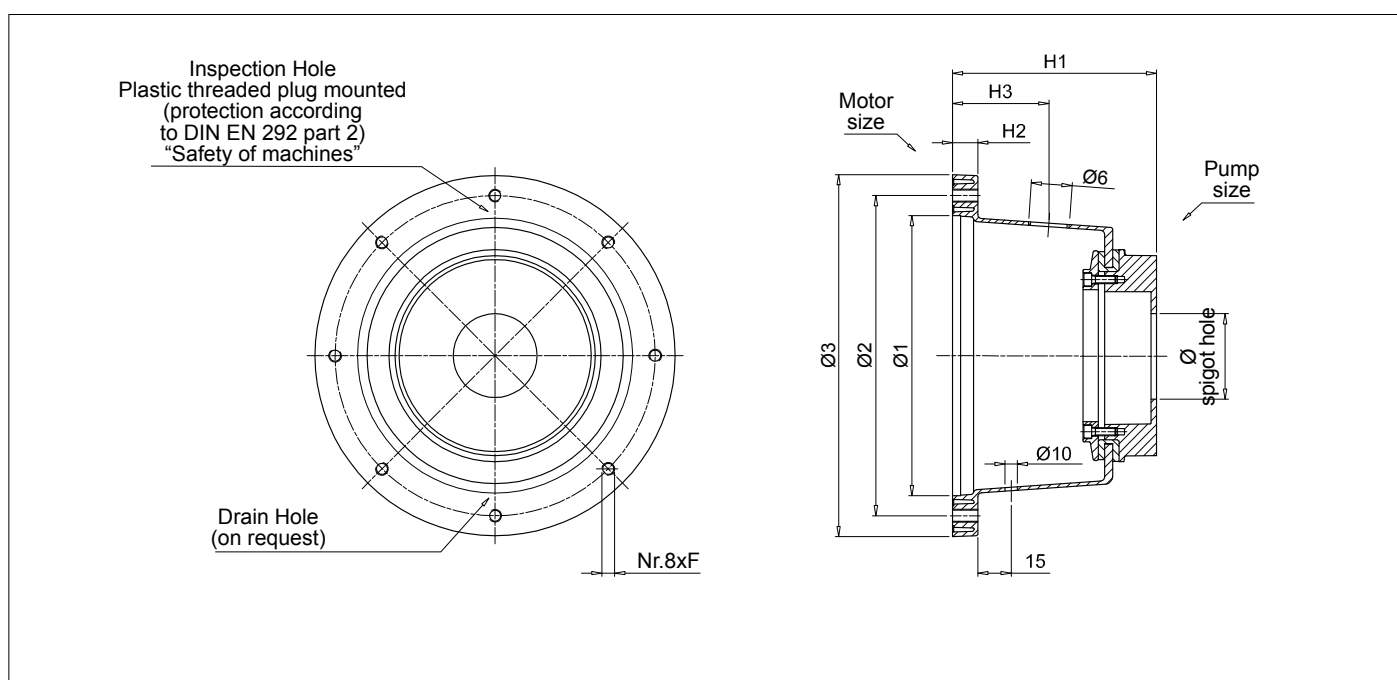

IEC - Electric motors		Bell-housing code	Dimensions [mm]							On request		Ø spigot hole Minimum [mm]	Weight [kg]
Motor size	Shaft end [Ø x L]		Ø1	Ø2	Ø3	H1	H2	F	P	H3	Ø6		
225	60x140	LMS450AFS0***	350	400	450	255	31	M16	-	175	1 1/2"	80	12.1
250	65x140	LMS550AFSP***	450	500	550	255	31	M16	-	176	1 1/2"	80	15.2
280	75x140	LMS550AFSR***	450	500	550	270	31	M16	-	177	1 1/2"	80	15.9
315	80x170	LMS660AFST***	550	600	660	305	42	M20	-	179	1 1/2"	80	20.2

Dimensions

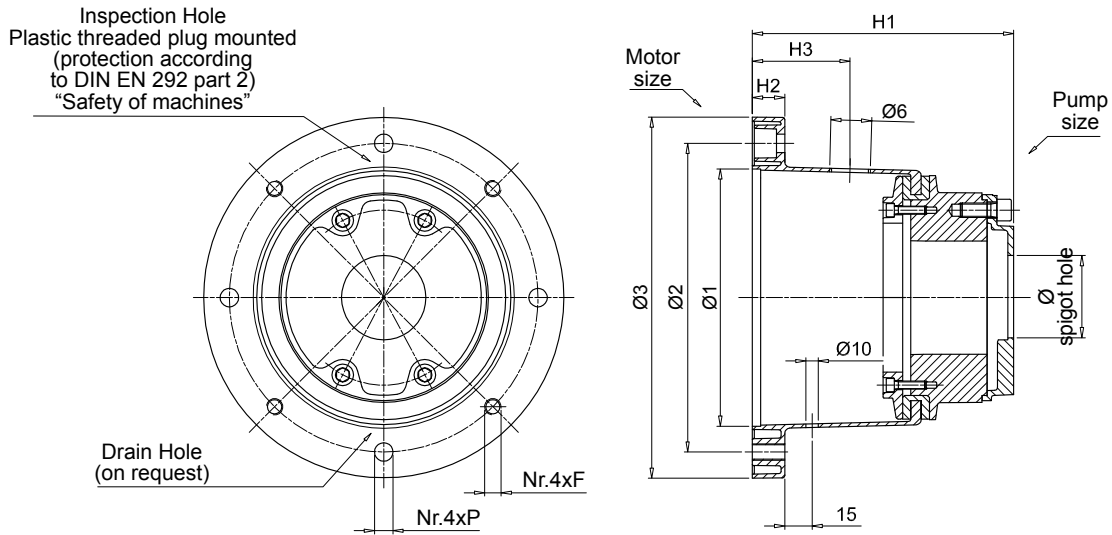

IEC - Electric motors		Bell-housing code	Dimensions [mm]							On request		Ø spigot hole Minimum [mm]	Weight [kg]
Motor size	Shaft end [Ø x L]		Ø1	Ø2	Ø3	H1	H2	F	P	H3	Ø6		
100 - 112	28x60	LDS250AFRA***	180	215	250	158	19	M12	14	75	3/4"	50	3.97
		LDS250AFRB***	180	215	250	165	19	M12	14	75	3/4"	50	4.10
		LDS250AFRE***	180	215	250	173	19	M12	14	75	3/4"	50	4.70
132	38x80	LDS300AFRB***	230	265	300	185	23	M12	14	80	3/4"	50	4.75
		LDS300AFRC***	230	265	300	188	23	M12	14	80	3/4"	80	4.85
		LDS300AF5G***	230	265	300	232	23	M12	14	80	3/4"	80	6.70
160 180	42x110 48x110	LDS350AF5A***	250	300	350	254	31	M16	18	95	1"	80	8.10
200	55x110	LDS400AF6A***	300	350	400	288	31	M16	18	125	1 1/2"	80	10.00

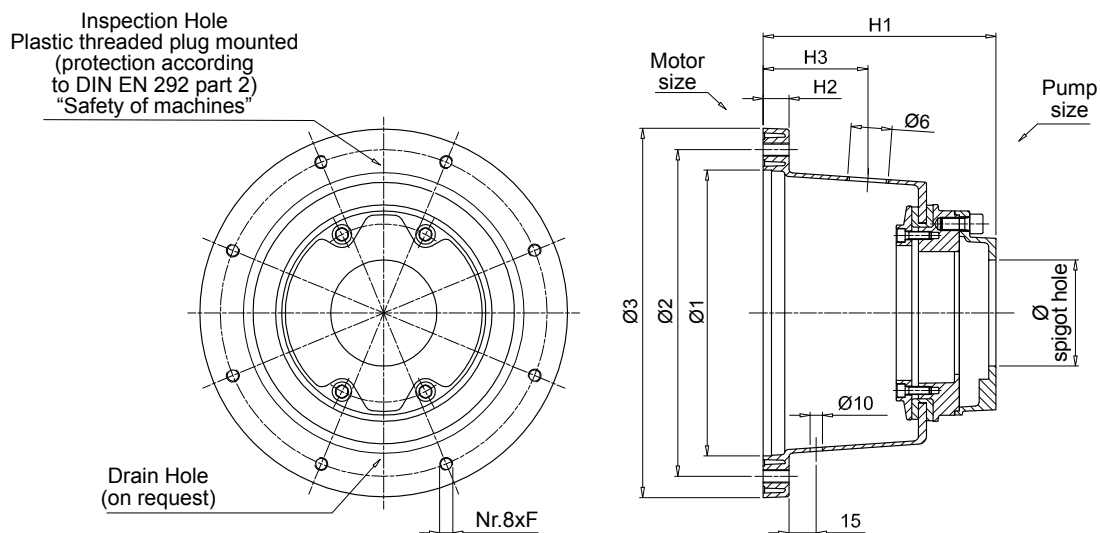

IEC - Electric motors		Bell-housing code	Dimensions							On request		Ø spigot hole Minimum [mm]	Weight [kg]
Motor size	Shaft end [Ø x L]		Ø1	Ø2	Ø3	H1	H2	F	P	H3	Ø6		
225	60x140	LDS450AF6A***	350	400	450	287	31	M16	-	175	1 1/2"	80	14.10
250	65x140	LDS550AF6A***	450	500	550	300	31	M16	-	176	1 1/2"	80	17.20
280	75x140												
315	80x170	LDS660AF6A***	550	600	660	335	42	M20	-	179	1 1/2"	80	23.00

Comparative table

MP Filtri code	KTR code	OMT code	Raja code
LMS250A***	PK+D150/190	BS251***	R250***DF
LMS300A***	PK+D150/190	BS300***	R300***DF
LMS350A***	PK+D150/D190/D230/260	BS350***	R350***DF
LMS400A***	PK+/D190/D230/260	BS400***	R400***DF
LMS450A***	PK+/D190/D230/260D/D330	BS451***	R450***DF
LMS550A***	PK+/D190/D230/260D/D330	BS551***	R550***DF
LMS660A***	PK+/D190/D230/260D/D330	BS661***	R660***DF

Note:

The above table is guideline only.

Not all bell-housings are fully interchangeable.

MULTI-COMPONENTS

IEC electric motor range from size 132 up to size 355



Technical data

Modular Bell-Housing Components - IEC electric motor range from size 132 up to size 355

Materials

- Base module: Pressure die-cast aluminium alloy
- Pump flange: Aluminium alloy
- Intermediate adapter: Aluminium alloy.
- Screw kit: Steel
- Gaskets: Special paper (Guarnital)

Compatibility with fluids

Modular bell-housing components compatible for use with:

- Mineral oils types HH-HL-HM-HR-HV, to ISO 6743/4 standard
- Water based emulsions types HFAE-HFAS, to ISO 6743/4 standard
- Water glycol type HFC, to ISO 6743/4 standard: ask for anodized version

Special Applications

Any applications not covered by the normal indications contained in this catalogue must be evaluated and approved by MP Filtri Technical and Sales Department

Temperature

From -30 °C to +80 °C

Note

For temperatures outside this range, contact MP Filtri Technical and Sales Department



BMC

Bell-Housing size	Flange ISO 3019-2							IEC Motors size	
	50 B2-B4	63 B2-B4	80 B2-B4	100 B2-B4	125 B2-B4	160 B2-B4	200 B2-B4		
BMC200	●	●	●	●					IEC 80 Ø200 - Ø19x40
BMC200	●	●	●	●					IEC 90 Ø200 - Ø24x50
BMC250	●	●	●	●	●				IEC 100 Ø250 - Ø28x60
BMC250	●	●	●	●	●				IEC 112 Ø250 - Ø28x60
BMC300			●	●	●	●			IEC 132 Ø300 - Ø38x80
BMC350			●	●	●	●			IEC 160 Ø350 - Ø42x110
BMC350			●	●	●	●	●		IEC 180 Ø350 - Ø48x110
BMC400			●	●	●	●	●	●	IEC 200 Ø400 - Ø55x110
BMC450			●	●	●	●	●	●	IEC 225 Ø450 - Ø60x140

Bell-Housing size	Flange SAE J 744										IEC Motors size		
	50-2 (A-A)	82-2 (A)	101-2 (B)	127-2 (C)	152-2 (D)	165-2 (E)	101-4 (B)	127-4 (D)	152-4 (D)	165-4 (E)			
BMC200	●	●											IEC 80 Ø200 - Ø19x40
BMC200	●	●											IEC 90 Ø200 - Ø24x50
BMC250	●	●	●				●						IEC 100 Ø250 - Ø28x60
BMC250	●	●	●	●			●						IEC 112 Ø250 - Ø28x60
BMC300		●	●	●			●	●					IEC 132 Ø300 - Ø38x80
BMC350		●	●	●			●	●					IEC 160 Ø350 - Ø42x110
BMC350		●	●	●	●		●	●	●				IEC 180 Ø350 - Ø48x110
BMC400		●	●	●	●	●	●	●	●	●			IEC 200 Ø400 - Ø55x110
BMC450			●	●	●	●	●	●	●	●			IEC 225 Ø450 - Ø60x140

BMT

Bell-Housing size	Flange ISO 3019-2							IEC Motors size	
	50 B2-B4	63 B2-B4	80 B2-B4	100 B2-B4	125 B2-B4	160 B2-B4	200 B2-B4		
BMT300			●	●	●	●			IEC 132 Ø300 - Ø38x80
BMT350			●	●	●	●			IEC 160 Ø350 - Ø42x110
BMT350			●	●	●	●	●		IEC 180 Ø350 - Ø48x110
BMT400			●	●	●	●	●	●	IEC 200 Ø400 - Ø55x110
BMT450			●	●	●	●	●	●	IEC 225 Ø450 - Ø60x140
BMT550						●	●	●	IEC 250 Ø550 - Ø65x140
BMT550						●	●	●	IEC 280 Ø550 - Ø75x140
BMT660						●	●	●	IEC 315 Ø660 - Ø80x170
BAD800						●	●	●	IEC 355 Ø800 - Ø95x210

Bell-Housing size	Flange SAE J 744										IEC Motors size		
	50-2 (A-A)	82-2 (A)	101-2 (B)	127-2 (C)	152-2 (D)	165-2 (E)	101-4 (B)	127-4 (D)	152-4 (D)	165-4 (E)			
BMT300		●	●	●			●	●					IEC 132 Ø300 - Ø38x80
BMT350		●	●	●			●	●					IEC 160 Ø350 - Ø42x110
BMT350		●	●	●		●	●	●	●				IEC 180 Ø350 - Ø48x110
BMT400		●	●	●	●	●	●	●	●	●			IEC 200 Ø400 - Ø55x110
BMT450			●	●	●	●	●	●	●	●			IEC 225 Ø450 - Ø60x140
BMT550				●	●	●		●	●	●			IEC 250 Ø550 - Ø65x140
BMT550				●	●	●		●	●	●			IEC 280 Ø550 - Ø75x140
BMT660				●	●	●		●	●	●			IEC 315 Ø660 - Ø80x170
BAD800				●	●	●		●	●	●			IEC 355 Ø800 - Ø95x210

MULTI-COMPONENTS

Designation & Ordering code

BMC

1 Motor base series and size			Configuration example: BMC200A1001	DI
BMC200A1001	BMC300A1551	BMC400A2016		
BMC200A1251	BMC300A1555	BMC450A2507		
BMC250A1141	BMC300A1705			
BMC250A1361	BMC350A1945			
	BMC350A1946			
BMT300A0805	BMT550A21567			
BMT350A1105	BMT660A25067			
BMT400A1106	BAD800A2707			
BMT450A1406				

Options	
DI	Drain hole + inspection hole
AN	Black anodized finish
SA	Clearance holes at motor interface
Pxx	Customer specification

2 Intermediate adapter series and size			Configuration example: AD60465	AN
AD60465				
AD50385				
AD60466				
AD50386				
AD50467				
AD60467				

Options	
AN	Black anodized finish
Pxx	Customer specification

3 Pump flange series and size				Configuration example: FP5026	070	AN
FR1023	FP5026	FP6032	FP7052			
FR1025	FP5032	FP6045	FP7066			
FR1033	FP5035	FP6058	FP7069			
FR1035	FP5045	FP6070	FP7086			
FR1040	FP5056	FP6082	FP70111			
FR1079	FP5063	FP6086				
	FP5091	FP60101				
		FP60110				

Pump interface codes	
070	See page 60

Options	
FR	Holes rotated through 45° in relation to standard position
DP	Double set of hole
AN	Black anodized finish
Pxx	Customer specification

Options	
Mounting kit code series and size	
KVG1	
KVG5	
KVG6	See page 111
KVG7	

1

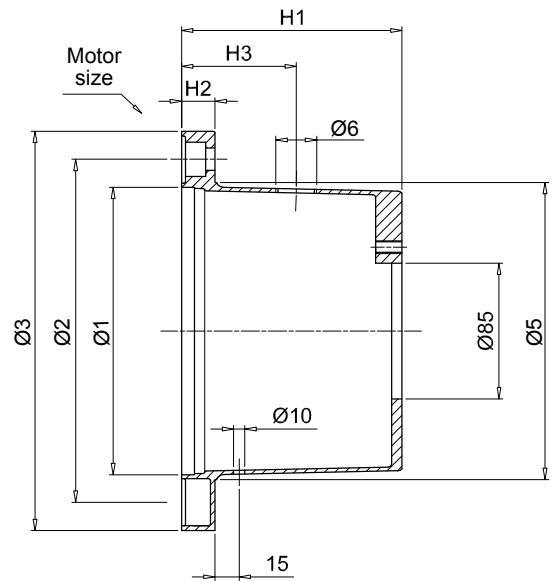
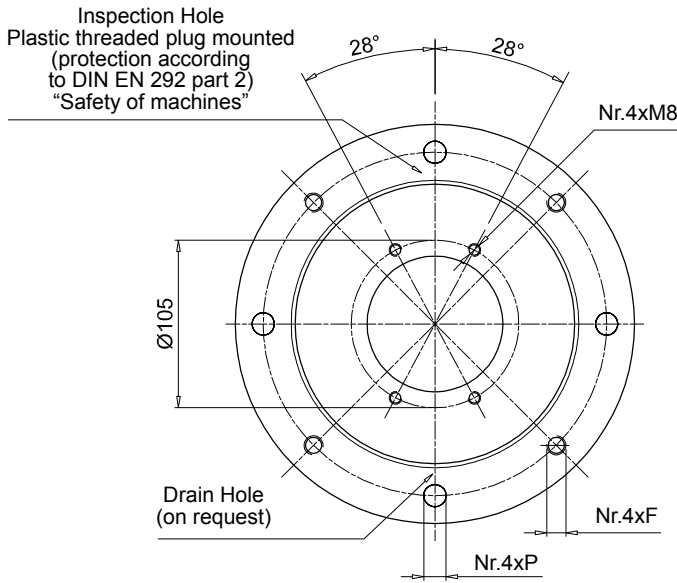

IEC - Electric motors		Motor base code	Dimensions [mm]								On request		Weight [kg]
Motor size	Shaft end [Ø x L]		Ø1	Ø2	Ø3	Ø5	H1	H2	F	P	H3	Ø6	
80	19x40	BMC200A1001	130	165	200	135	100	18	M10	11	60	3/4"	0.75
90	24x50	BMC200A1251	130	165	200	135	125	18	M10	11	75	3/4"	0.95
100-112	28x60	BMC250A1141	180	215	250	186	114	19	M12	14	80	3/4"	1.60
		BMC250A1361	180	215	250	186	138	19	M12	14	100	3/4"	1.60
132	38x80	BMC300A1551	230	265	300	235	155	23	M12	14	95	3/4"	3.30

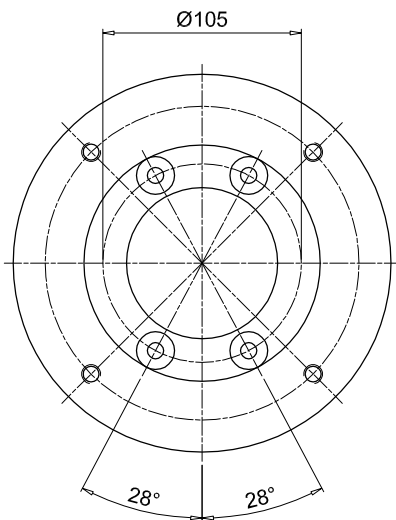

4 Bolt Version

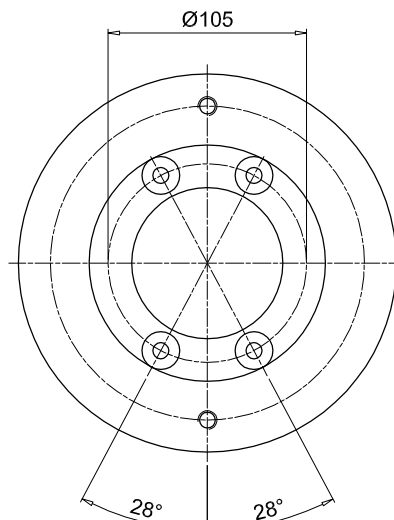

2 Bolt Version

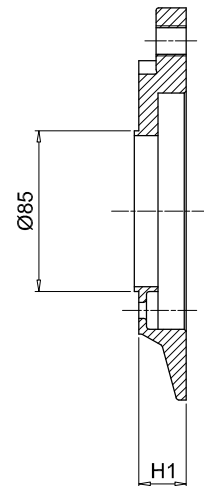

3

Pump flange code	H1	Mounting kit	Available pump interface		Weight [kg]
			2 Bolt	4 Bolt	
FR1023***	23	KVG1 See page 111	D042 - S061 - S063 - S083 - S023 - S070 - S071 - S082 - S075	S024 - S025 - S125 - S154	0.25
FR1025***	25		S080 - S082	S021 - S026 - S068 - S069	0.30
FR1033***	33		S023 - S070 - S071 - S072 - S074 S080 - S082	S021 - S026 - S027	0.80
FR1035***	35		S060 - S063 - S065	-	0.90
FR1040***	40		-	S098 - S227	1.10
FR1079***	79		-	S031	1.30

Pump flange code to be complete with available pump interface

Example: **FR1023S024**

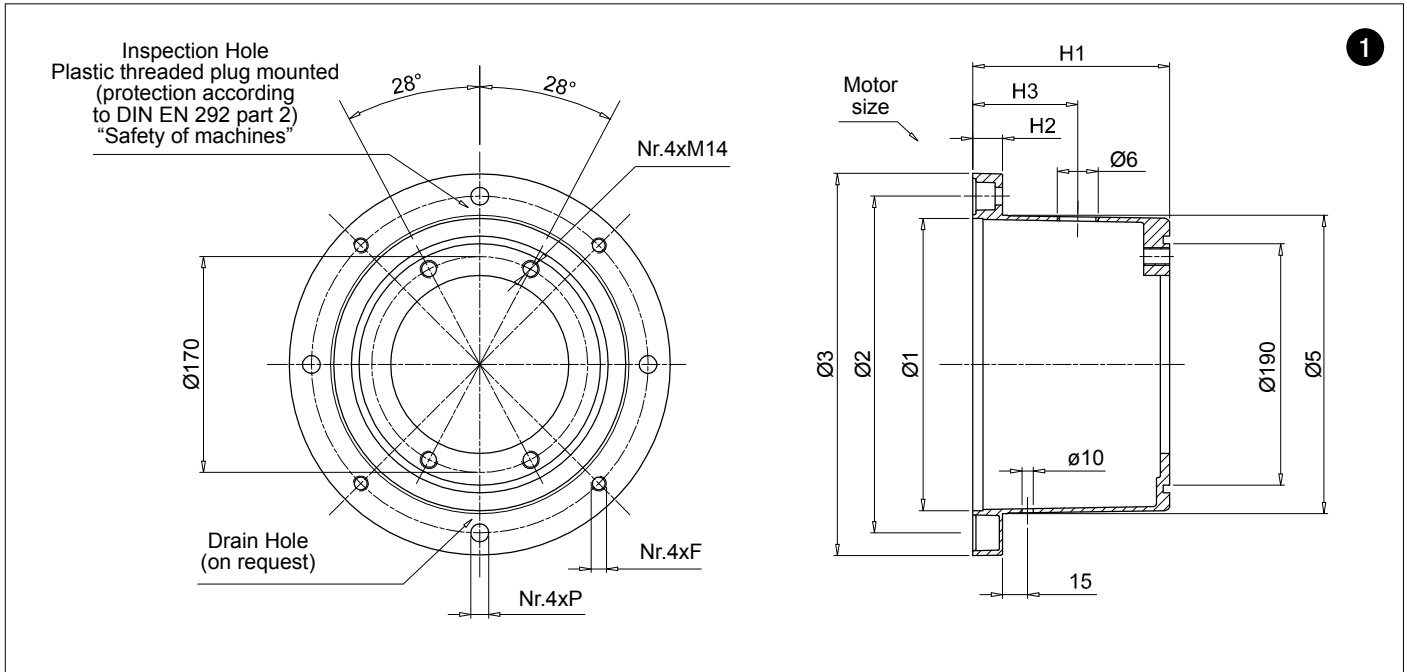

IEC - Electric motors		Motor base code	Dimensions [mm]								On request		Weight [kg]
Motor size	Shaft end [Ø x L]		Ø1	Ø2	Ø3	Ø5	H1	H2	F	P	H3	Ø6	
132	38x80	BMC300A1555	230	265	300	235	155	23	M12	14	95	3/4"	3.3
		BMC300A1705	230	265	300	235	170	23	M12	14	110	3/4"	3.6
160	42x110	BMC350A1785	250	300	350	254	178	31	M16	18	100	1"	4.4
180	48x110	BMC350A1945	250	300	350	254	194	31	M16	18	115	1"	4.9

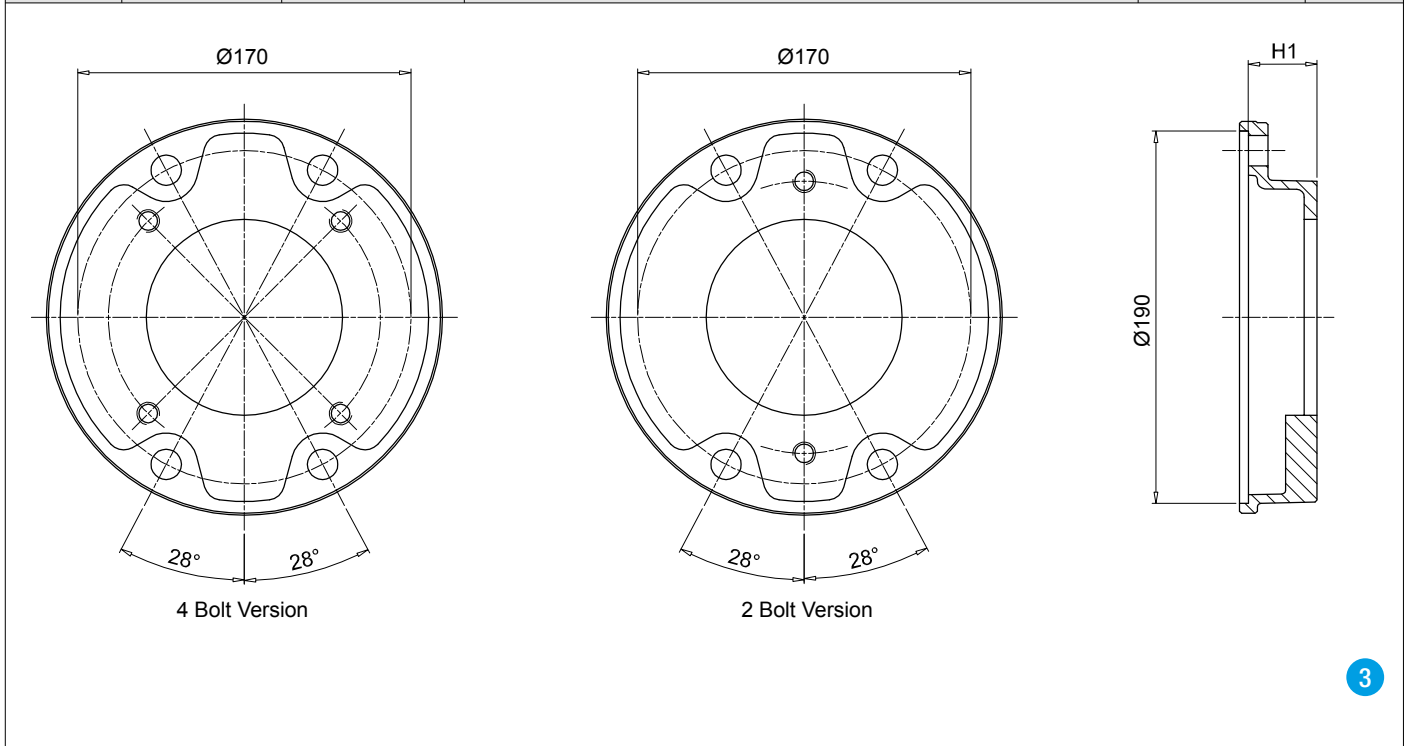

Pump flange code	H1	Mounting kit	Available pump interface		Weight [kg]
			2 Bolt	4 Bolt	
FP5026***	26	KVG5 See page 111	S023 - D042 - S063 - S070 - S072 S075	S024 - S024 - S033 - S125 - S154	1.0
FP5032***	32		-	S024 - S031 - S096 - S125	1.1
FP5035***	35		S023 - D042 - S063 - S070 - S072 - S075 - S060 - S072 - S074 - S075 - S106	S021 - S024 - S025 - S026 - S031 - S059 - S068 - S083 - S097 - S125 - S141	0.9
FP5045***	45		S060 - S070 - S071 - S072 - S074 - S075 - S106	S021 - S024 - S025 - S026 - S068 - S125 - S141	0.9
FP5056***	56		S072	S021 - S026	1.6
FP5063***	63		S070 - S079 - S138	S021 - S025 - S068 - S141	1.7
FP5091***	91		-	S025 - S031 - S033 - S113 - S267	2.2

Pump flange code to be complete with available pump interface

Example: **FP5026S023**

1

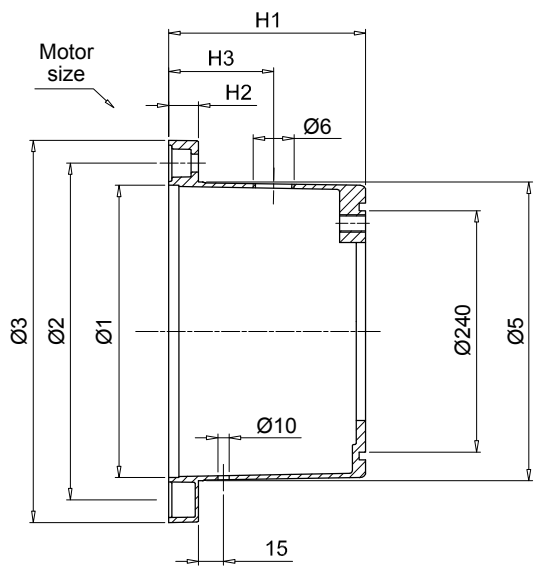
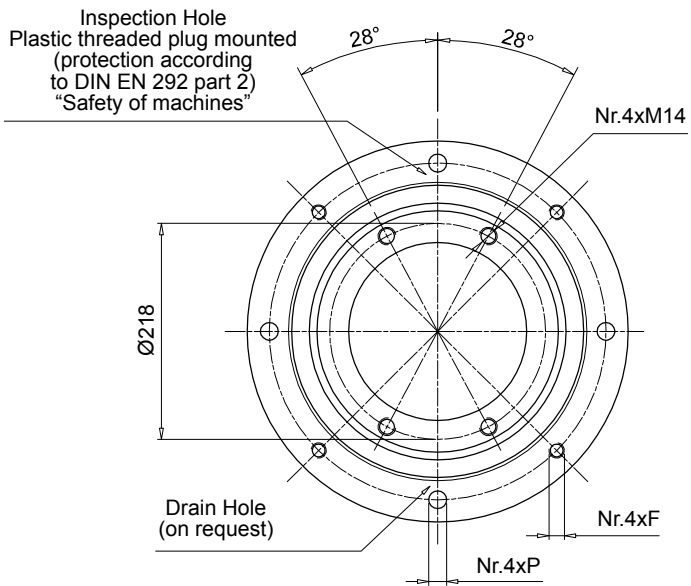

IEC - Electric motors		Motor base code	Dimensions [mm]								On request		Weight [kg]
Motor size	Shaft end [Ø x L]		Ø1	Ø2	Ø3	Ø5	H1	H2	F	P	H3	Ø6	
160	42x110	BMC350A1786	250	300	350	254	178	31	M16	18	100	1"	4.4
180	48x110	BMC350A1946	250	300	350	254	194	31	M16	18	115	1"	1.9
200	55x110	BMC400A2016	300	350	400	305	201	31	M16	18	125	1 1/2"	6.9

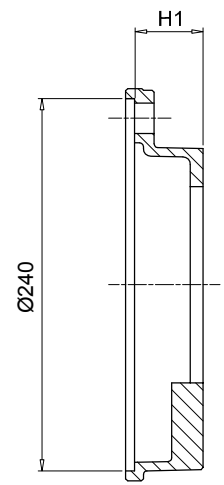
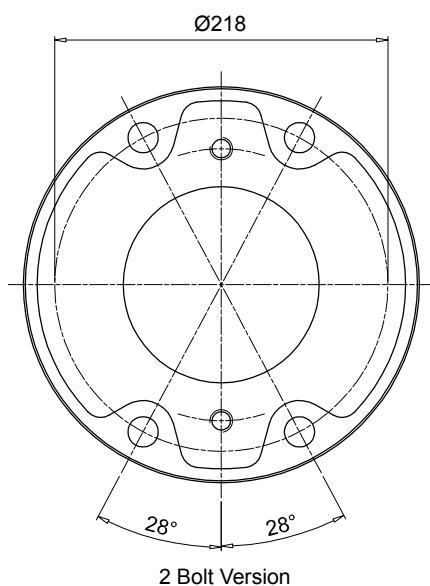
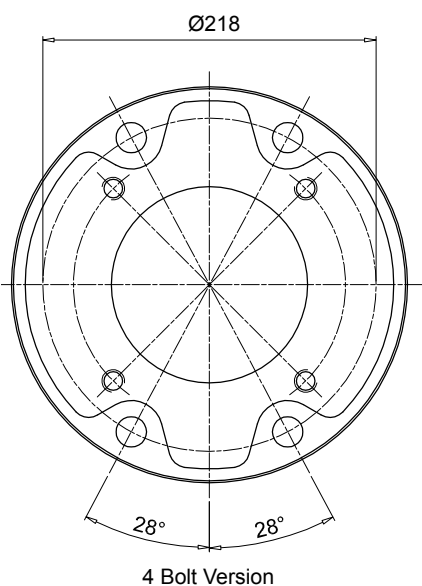

3

Pump flange code	H1	Mounting kit	Available pump interface		Weight [kg]
			2 Bolt	4 Bolt	
FP6032***	32	KVG6 See page 111	S081 - S082	S021 - S035	1.8
FP6045***	45		S070 - S075 - S080 - S081 - S082	S021 - S025 - S026 - S027 - S069 - S077 - S125 - S198 - S207 - S215 - S253	2.1
FP6058***	58		S079 - S080 - S081 - S082	S025 - S026 - S027 - S038 - S077 - S078 - S207 - S215 - S237	2.4
FP6070***	70		S080	-	3.0
FP6082***	82		S080 - S081	S038 - S141 - 198 - 215	3.3
FP6086***	86		S090 - S092 - S166 - S091	S021 - S026 - S027 - S077 - S078 - S114 - S132 - 198 - S200	3.4
FP6101***	101		-	S027 - S035 - S113 - S132 - S148 - S176 - S228	4.2
FP6110***	110		S080	S111	5.5

Pump flange code to be complete with available pump interface
 Example: **FP6032S021**

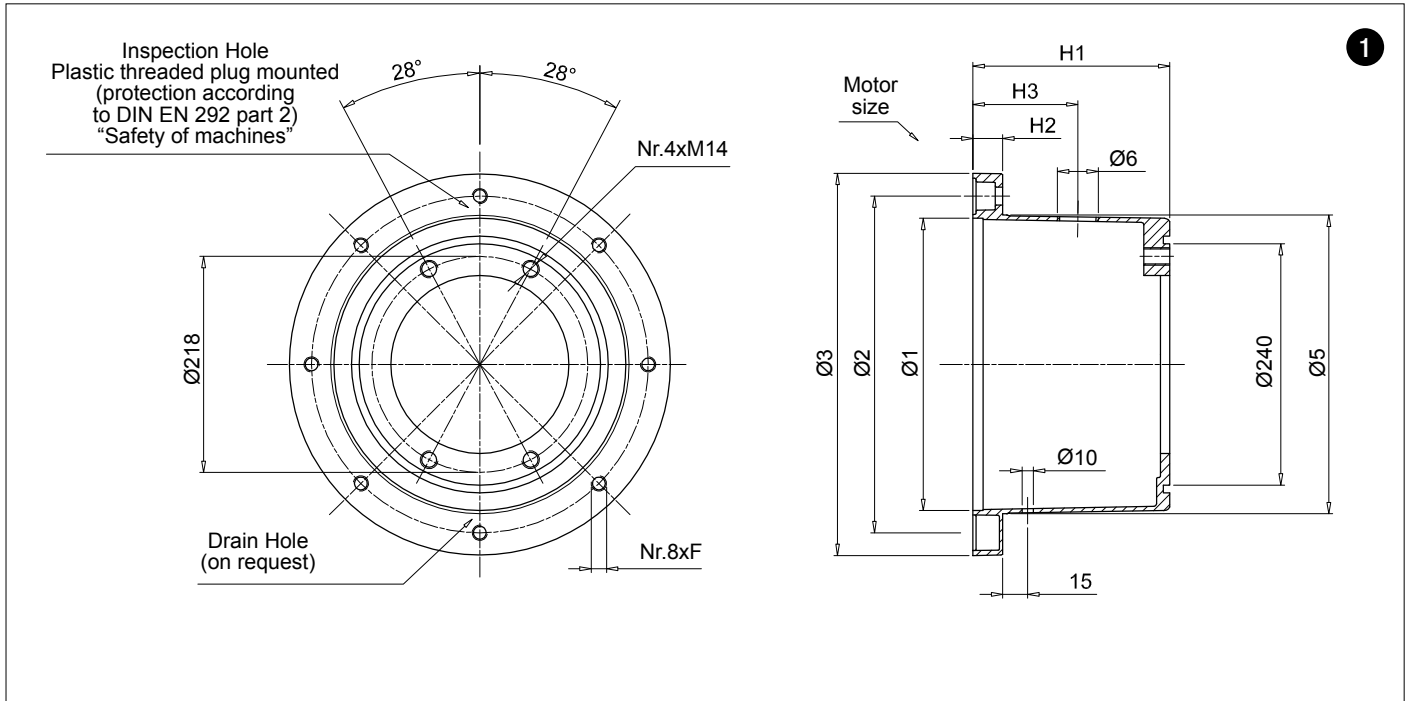

IEC - Electric motors		Motor base code	Dimensions [mm]								On request		Weight [kg]
Motor size	Shaft end [Ø x L]		Ø1	Ø2	Ø3	Ø5	H1	H2	F	P	H3	Ø6	
225	60x140	BMC450A2506	350	400	450	350	250	31	M16	-	175	1 1/2"	6.9

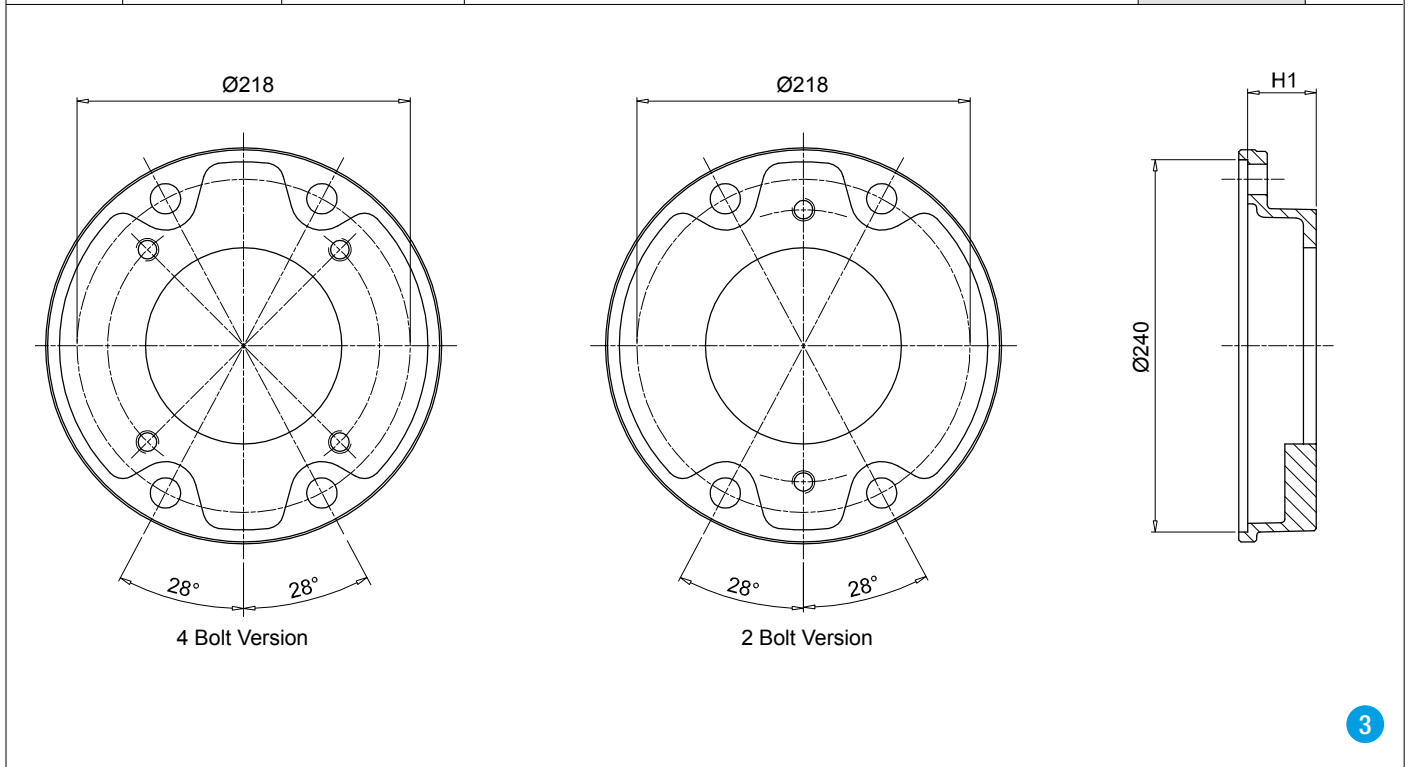

Pump flange code	H1	Mounting kit	Available pump interface		Weight [kg]
			2 Bolt	4 Bolt	
FP6032***	32	KVG6 See page 111	S081 - S082	S021 - S035	1.8
FP6045***	45		S070 - S075 - S080 - S081 - S082	S021 - S025 - S026 - S027 - S069 - S077 - S125 - S198 - S207 - S215 - S253	2.1
FP6058***	58		S079 - S080 - S081 - S082	S025 - S026 - S027 - S038 - S077 - S078 - S207 - S215 - S237	2.4
FP6070***	70		S080	-	3.0
FP6082***	82		S080 - S081	S038 - S141 - 198 - 215	3.3
FP6086***	86		S090 - S092 - S166 - S091	S021 - S026 - S027 - S077 - S078 - S114 - S132 - 198 - S200	3.4
FP6101***	101		-	S027 - S035 - S113 - S132 - S148 - S176 - S228	4.2
FP6110***	110		S080	S111	5.5

Pump flange code to be complete with available pump interface
 Example: **FP6032S021**

1

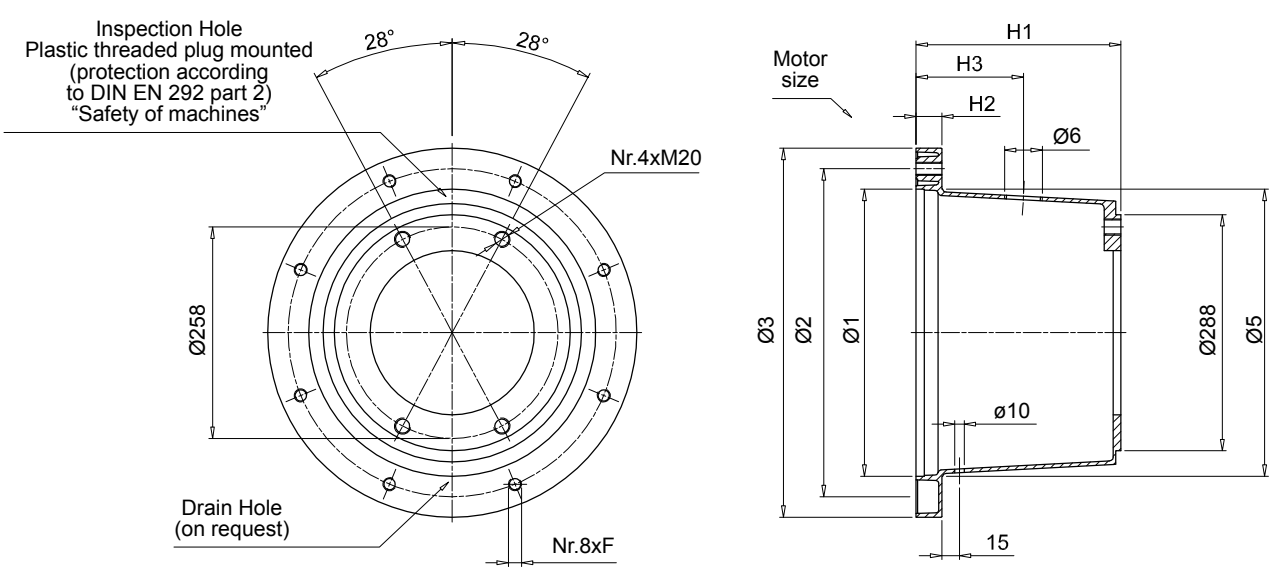

IEC - Electric motors		Motor base code	Dimensions [mm]								On request		Weight [kg]
Motor size	Shaft end [Ø x L]		Ø1	Ø2	Ø3	Ø5	H1	H2	F	P	H3	Ø6	
225	60x140	BMC450A2507	350	400	450	350	250	31	M16	-	175	1 1/2"	6.9

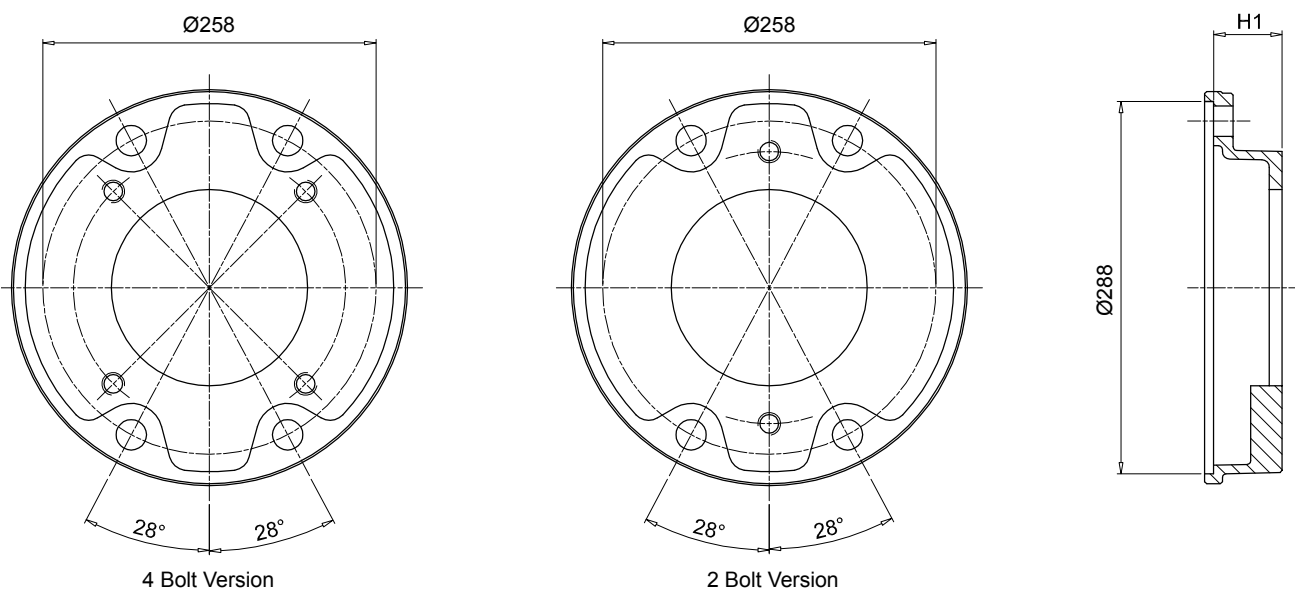

3

Pump flange code	H1	Mounting kit	Available pump interface		Weight [kg]
			2 Bolt	4 Bolt	
FP7052***	52	KVG7 See page 111	-	S028 - S108 - S112 - S133 - S192	4.4
FP7066***	66		S090 - S092 - S166	-	4.8
FP7069***	69		-	S108 - S143 - S148 - S192 - S201 - S204 - S281 - S282	4.9
FP7086***	86		S091 - S092 - S117 - S166	S022 - S027 - S028 - S108 - S112 - S184 - S192 - S201 - S228 - S300	5.2
FP7111***	111		S091 - S092 - S117 - S145	S028 - S108 - S112 - S133 - S184	6.3

Pump flange code to be complete with available pump interface
 Example: **FP7052S028**

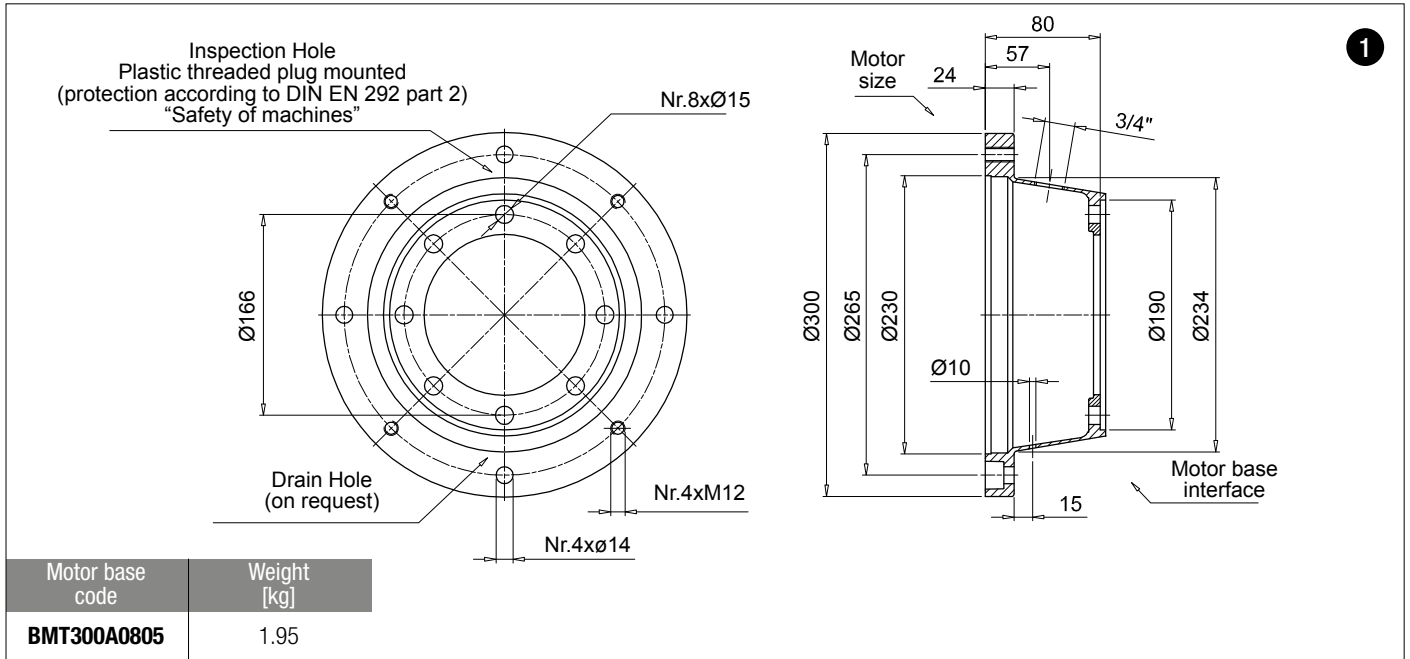

1

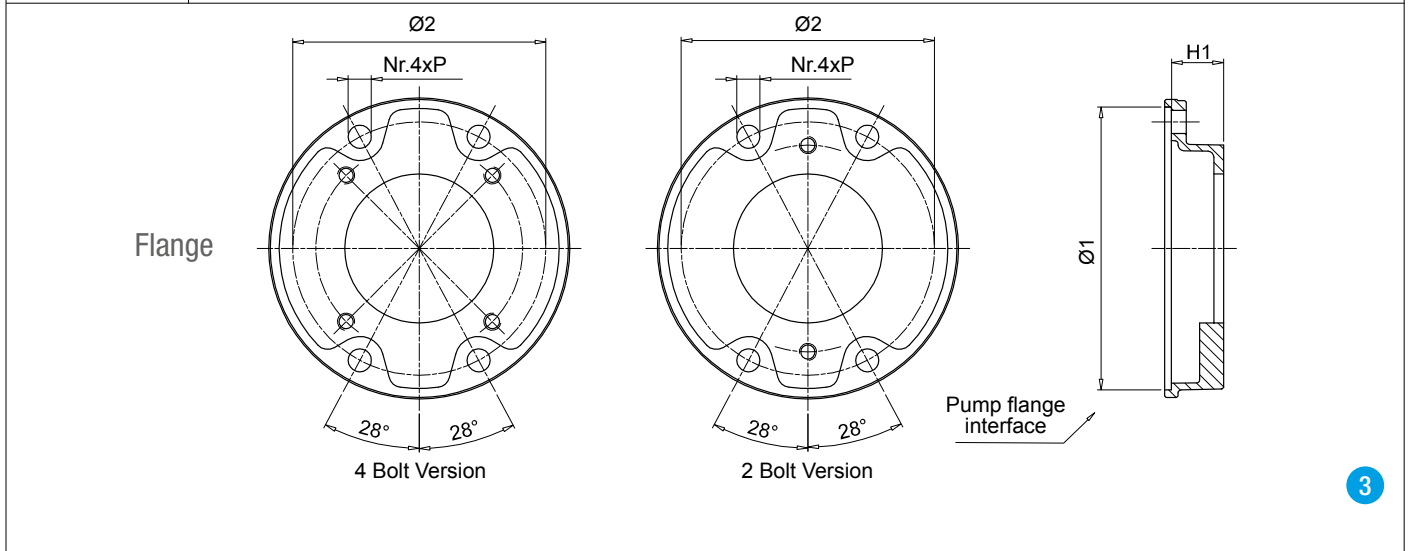

Pump flange code	H1	Ø1	Ø2	P	Mounting kit	Available pump interface		Weight [kg]
						2 Bolt	4 Bolt	
FP5026***	26	190	170	15	KVG5 See page 111	S023 - D042 - S063 - S070 - S072 S075	S024 - S024 - S033 - S125 - S154	1
FP5032***	32					-	S024 - S031 - S096 - S125	1.1
FP5035***	35					S023 - D042 - S063 - S070 - S072 - S075 - S060 - S072 - S074 - S075 - S106	S021 - S024 - S025 - S026 - S031 - S059 - S068 - S083 - S097 - S125 - S141	0.9
FP5045***	45					S060 - S070 - S071 - S072 - S074 - S075 - S106	S021 - S024 - S025 - S026 - S068 - S125 - S141	0.9
FP5056***	56					S072	S021 - S026	1.6
FP5063***	63					S070 - S079 - S138	S021 - S025 - S068 - S141	1.7
FP5091***	91					-	S025 - S031 - S033 - S113 - S267	2.2
FP6032***	32	240	218	17	KVG6 See page 111	S081 - S082	S021 - S035	1.8
FP6045***	45					S070 - S075 - S080 - S081 - S082	S021 - S025 - S026 - S027 - S069 - S077 - S125 - S198 - S207 - S215 - S253	2.1
FP6058***	58					S079 - S080 - S081 - S082	S025 - S026 - S027 - S038 - S077 - S078 - S207 - S215 - S237	2.4
FP6070***	70					S080	-	3.0
FP6082***	82					S080 - S081	S038 - S141 - 198 - 215	3.3
FP6086***	86					S090 - S092 - S166 - S091	S021 - S026 - S027 - S077 - S078 - S114 - S132 - 198 - S200	3.4
FP6101***	101					-	S027 - S035 - S113 - S132 - S148 - S176 - S228	4.2
FP6110***	110					S080	S111	5.5
FP7052***	52	288	258	22	KVG7 See page 111	-	S028 - S108 - S112 - S133 - S192	4.4
FP7066***	66					S090 - S092 - S166	-	4.8
FP7069***	69					-	S108 - S143 - S148 - S192 - S201 - S204 - S281 - S282	4.9
FP7086***	86					S091 - S092 - S117 - S166	S022 - S027 - S028 - S108 - S112 - S184 - S192 - S201 - S228 - S300	5.2
FP7111***	111					S091 - S092 - S117 - S145	S028 - S108 - S112 - S133 - S184	6.3

Pump flange code to be complete with available pump interface

Example: **FP6032S021**

Flange interface

Motor base interface

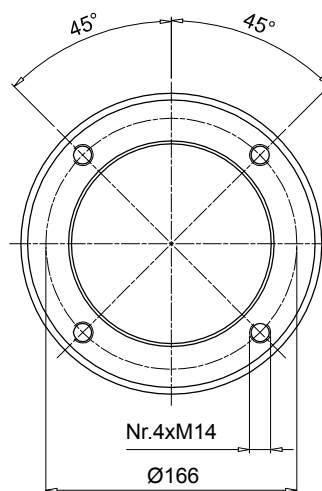
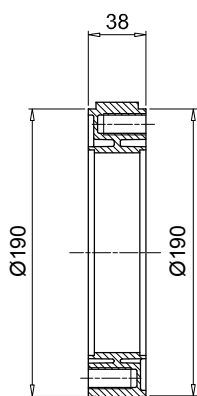
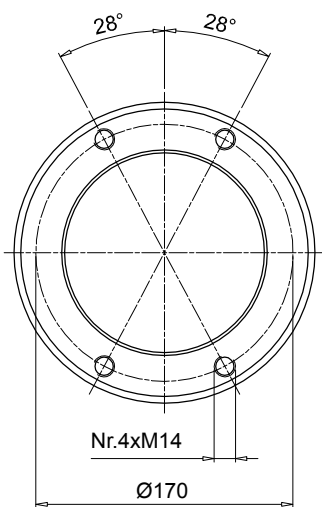

Code	Weight [kg]
AD50385	1.00

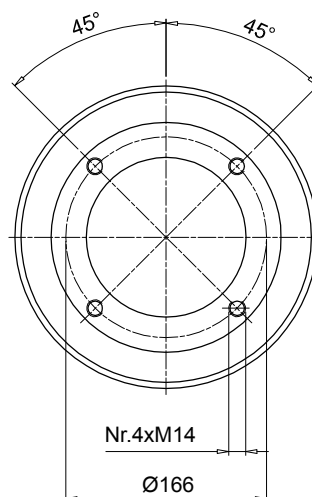
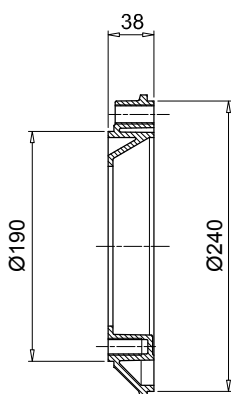
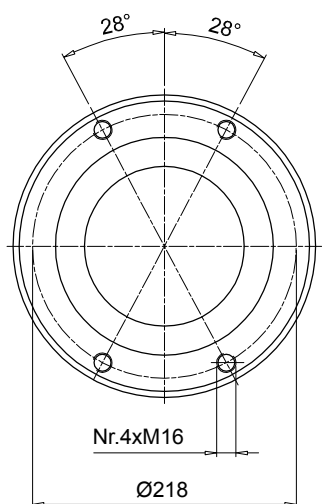

Code	Weight [kg]
AD50386	1.25

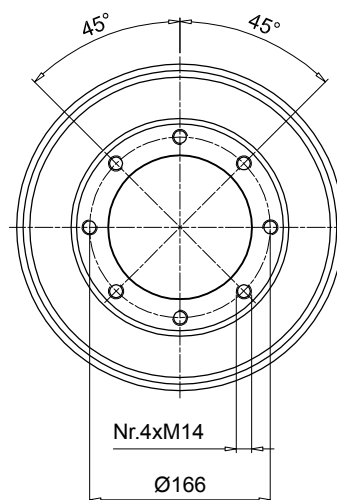
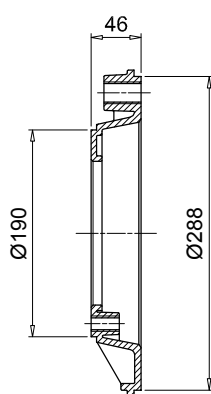
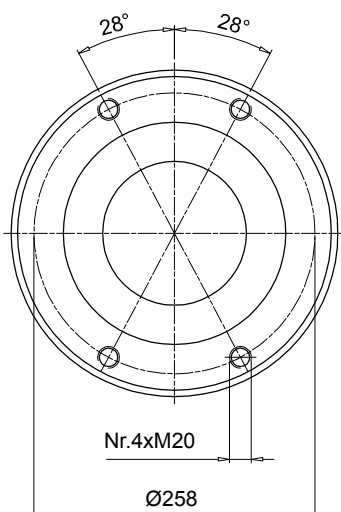

Code	Weight [kg]
AD50467	1.90

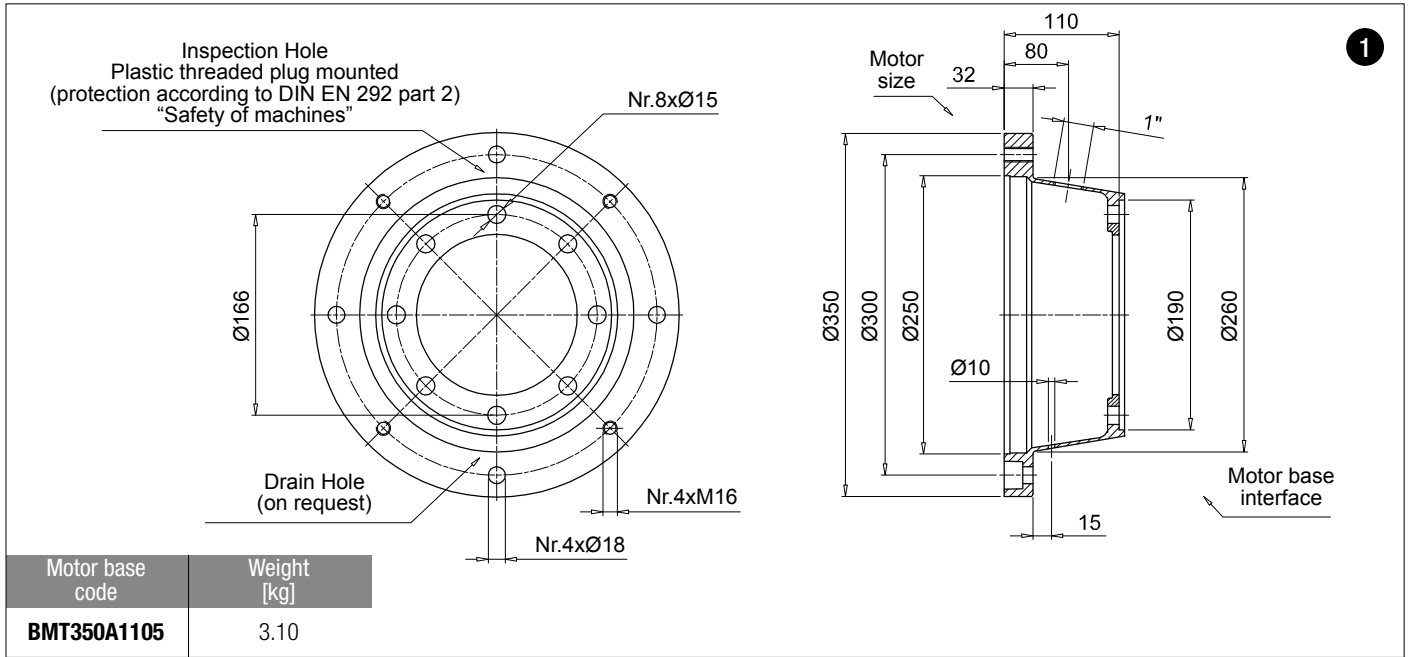

1

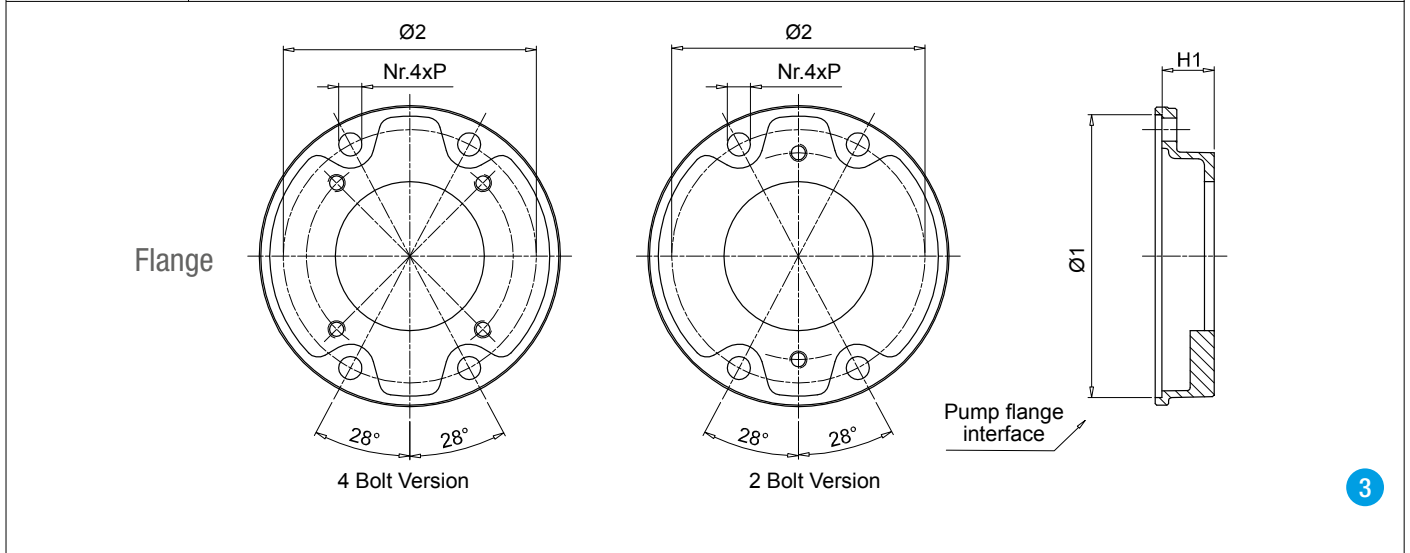

3

Pump flange code	H1	Ø1	Ø2	P	Mounting kit	Available pump interface		Weight [kg]
						2 Bolt	4 Bolt	
FP5026***	26				KVG5 See page 111	S023 - D042 - S063 - S070 - S072 S075	S024 - S024 - S033 - S125 - S154	1
FP5032***	32					-	S024 - S031 - S096 - S125	1.1
FP5035***	35					S023 - D042 - S063 - S070 - S072 - S075 - S060 - S072 - S074 - S075 - S106	S021 - S024 - S025 - S026 - S031 - S059 - S068 - S083 - S097 - S125 - S141	0.9
FP5045***	45					S060 - S070 - S071 - S072 - S074 - S075 - S106	S021 - S024 - S025 - S026 - S068 - S125 - S141	0.9
FP5056***	56	190	170	15		S072	S021 - S026	1.6
FP5063***	63					S070 - S079 - S138	S021 - S025 - S068 - S141	1.7
FP5091***	91					-	S025 - S031 - S033 - S113 - S267	2.2
FP6032***	32				KVG6 See page 111	S081 - S082	S021 - S035	1.8
FP6045***	45					S070 - S075 - S080 - S081 - S082	S021 - S025 - S026 - S027 - S069 - S077 - S125 - S198 - S207 - S215 - S253	2.1
FP6058***	58					S079 - S080 - S081 - S082	S025 - S026 - S027 - S038 - S077 - S078 - S207 - S215 - S237	2.4
FP6070***	70					S080	-	3.0
FP6082***	82	240	218	17		S080 - S081	S038 - S141 - 198 - 215	3.3
FP6086***	86					S090 - S092 - S166 - S091	S021 - S026 - S027 - S077 - S078 - S114 - S132 - 198 - S200	3.4
FP6101***	101					-	S027 - S035 - S113 - S132 - S148 - S176 - S228	4.2
FP6110***	110					S080	S111	5.5
FP7052***	52				KVG7 See page 111	-	S028 - S108 - S112 - S133 - S192	4.4
FP7066***	66					S090 - S092 - S166	-	4.8
FP7069***	69	288	258	22		-	S108 - S143 - S148 - S192 - S201 - S204 - S281 - S282	4.9
FP7086***	86					S091 - S092 - S117 - S166	S022 - S027 - S028 - S108 - S112 - S184 - S192 - S201 - S228 - S300	5.2
FP7111***	111					S091 - S092 - S117 - S145	S028 - S108 - S112 - S133 - S184	6.3

Pump flange code to be complete with available pump interface

Example: **FP6032S021**

Flange interface

Motor base interface

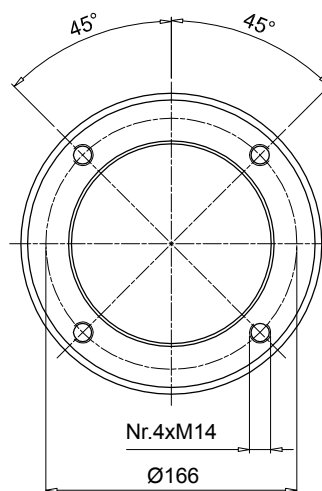
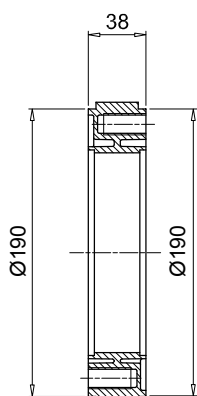
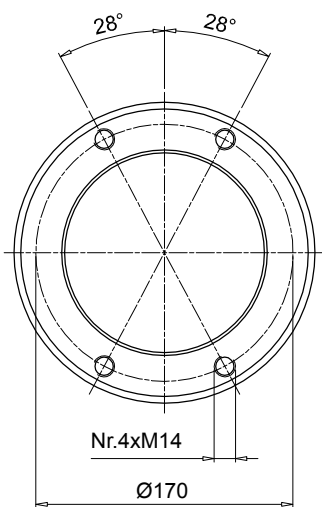

Code	Weight [kg]
AD50385	1.00

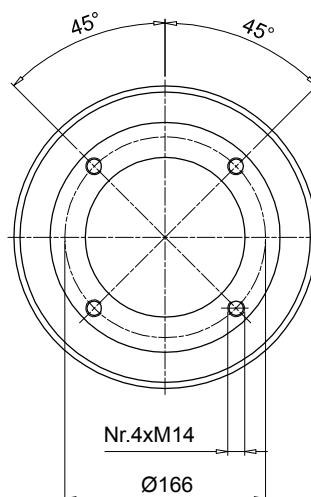
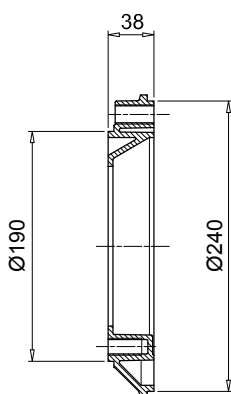
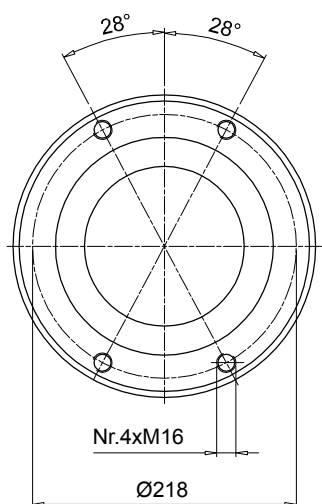

Code	Weight [kg]
AD50386	1.25

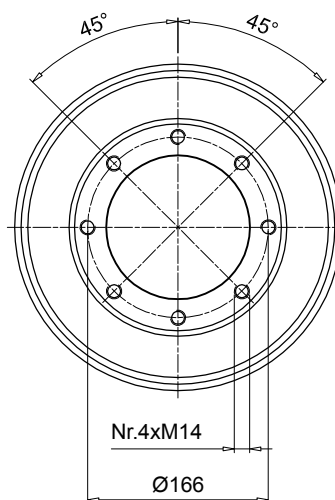
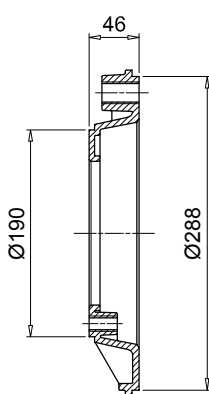
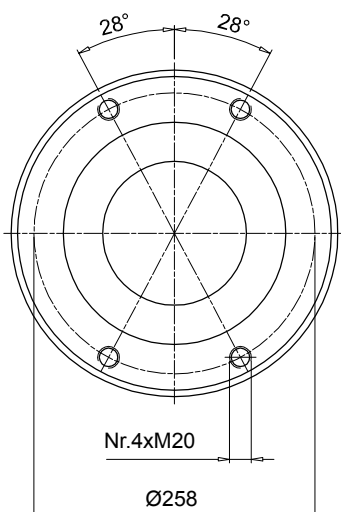

Code	Weight [kg]
AD50467	1.90

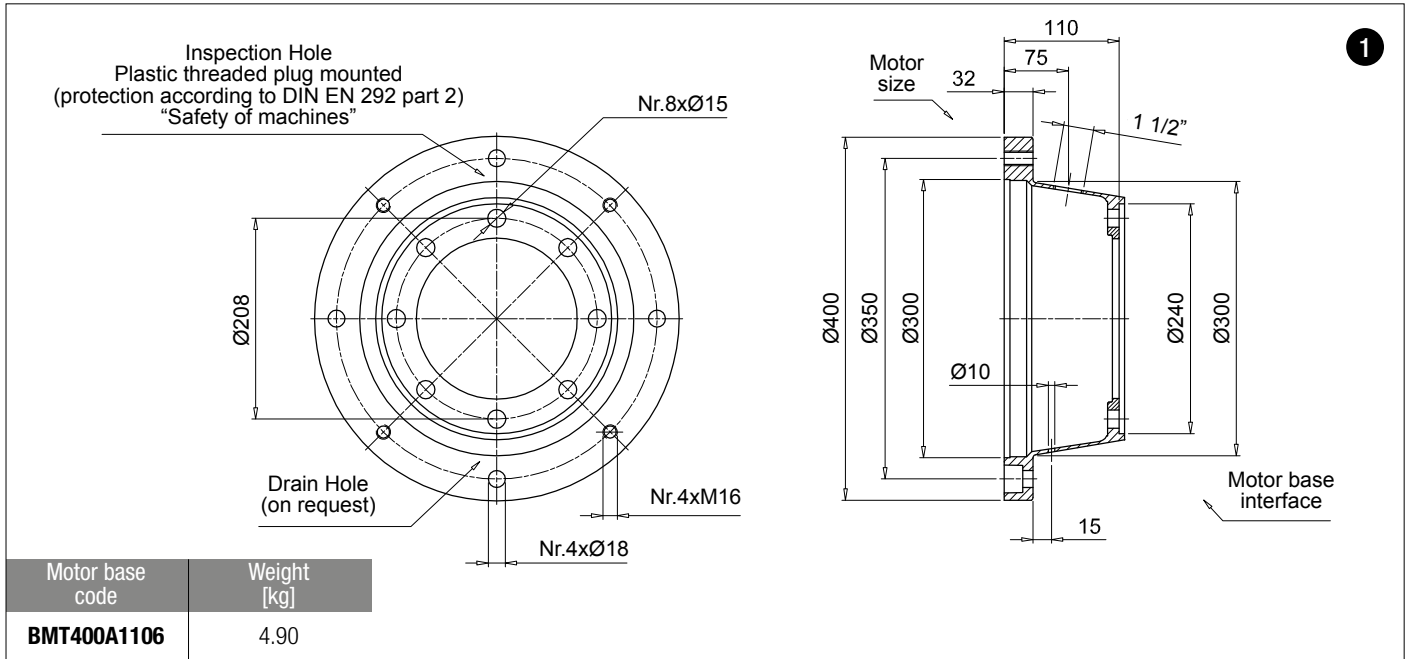

1

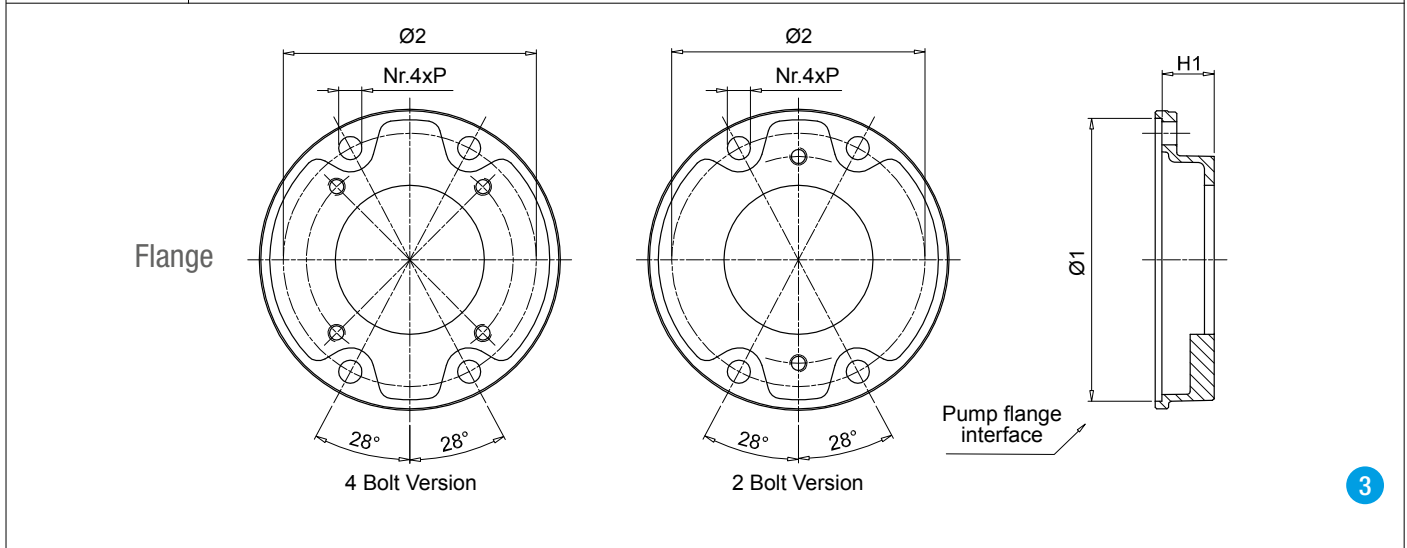

3

Pump flange code	H1	Ø1	Ø2	P	Mounting kit	Available pump interface		Weight [kg]
						2 Bolt	4 Bolt	
FP5026***	26				KVG5 See page 111	S023 - D042 - S063 - S070 - S072 S075	S024 - S024 - S033 - S125 - S154	1
FP5032***	32					-	S024 - S031 - S096 - S125	1.1
FP5035***	35					S023 - D042 - S063 - S070 - S072 - S075 - S060 - S072 - S074 - S075 - S106	S021 - S024 - S025 - S026 - S031 - S059 - S068 - S083 - S097 - S125 - S141	0.9
FP5045***	45					S060 - S070 - S071 - S072 - S074 - S075 - S106	S021 - S024 - S025 - S026 - S068 - S125 - S141	0.9
FP5056***	56	190	170	15		S072	S021 - S026	1.6
FP5063***	63					S070 - S079 - S138	S021 - S025 - S068 - S141	1.7
FP5091***	91				-	S025 - S031 - S033 - S113 - S267	2.2	
FP6032***	32				KVG6 See page 111	S081 - S082	S021 - S035	1.8
FP6045***	45					S070 - S075 - S080 - S081 - S082	S021 - S025 - S026 - S027 - S069 - S077 - S125 - S198 - S207 - S215 - S253	2.1
FP6058***	58					S079 - S080 - S081 - S082	S025 - S026 - S027 - S038 - S077 - S078 - S207 - S215 - S237	2.4
FP6070***	70					S080	-	3.0
FP6082***	82	240	218	17		S080 - S081	S038 - S141 - 198 - 215	3.3
FP6086***	86					S090 - S092 - S166 - S091	S021 - S026 - S027 - S077 - S078 - S114 - S132 - 198 - S200	3.4
FP6101***	101					-	S027 - S035 - S113 - S132 - S148 - S176 - S228	4.2
FP6110***	110					S080	S111	5.5
FP7052***	52				KVG7 See page 111	-	S028 - S108 - S112 - S133 - S192	4.4
FP7066***	66					S090 - S092 - S166	-	4.8
FP7069***	69	288	258	22		-	S108 - S143 - S148 - S192 - S201 - S204 - S281 - S282	4.9
FP7086***	86					S091 - S092 - S117 - S166	S022 - S027 - S028 - S108 - S112 - S184 - S192 - S201 - S228 - S300	5.2
FP7111***	111					S091 - S092 - S117 - S145	S028 - S108 - S112 - S133 - S184	6.3

Pump flange code to be complete with available pump interface

Example: **FP6032S021**

Flange interface

Motor base interface

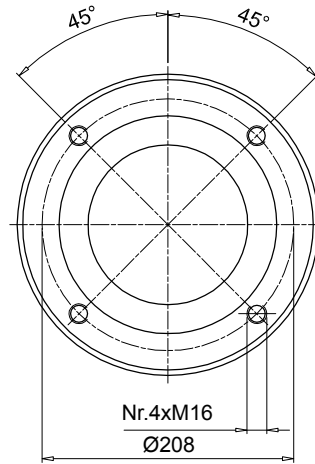
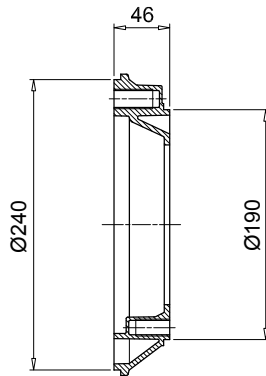
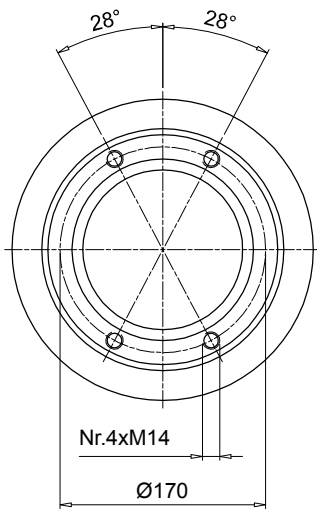

Code	Weight [kg]
AD60465	1.30

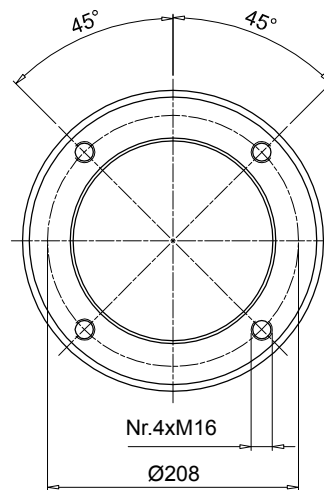
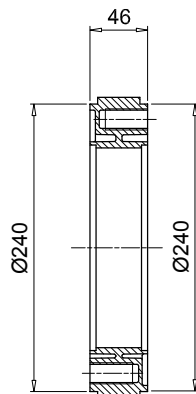
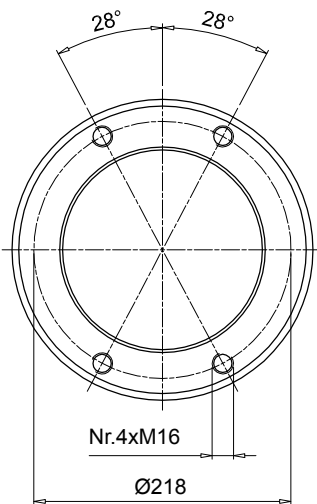

Code	Weight [kg]
AD60466	1.60

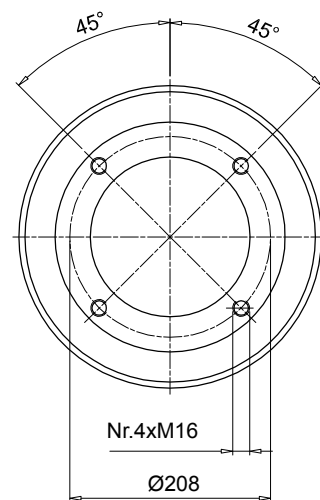
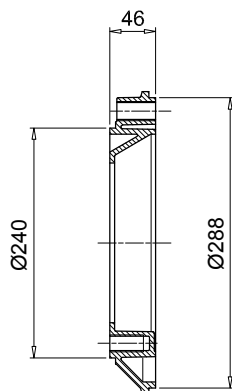
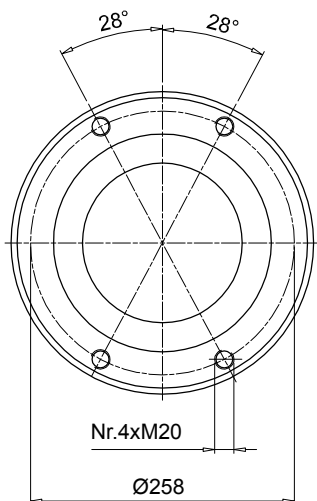

Code	Weight [kg]
AD60467	2.50

Inspection Hole
Plastic threaded plug mounted
(protection according to DIN EN 292 part 2)
"Safety of machines"

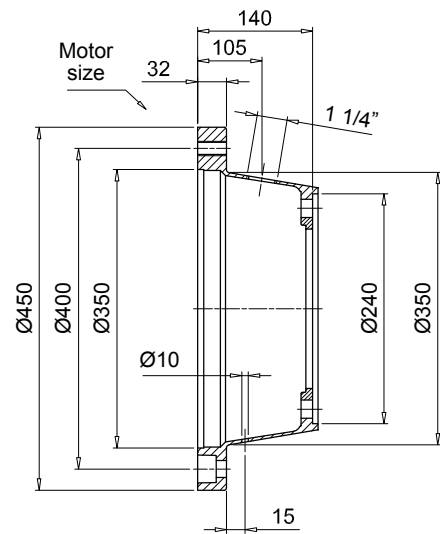
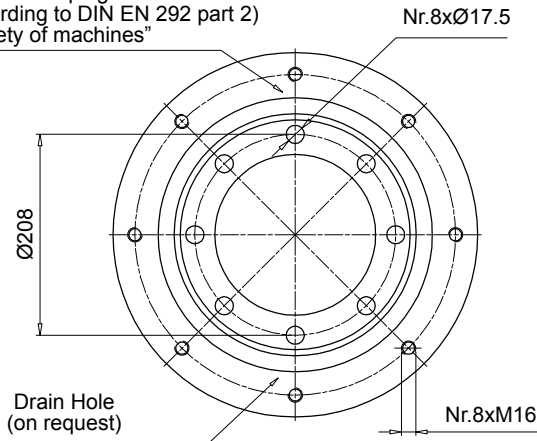

1

Motor base code	Weight [kg]
BMT450A1406	5.00

Flange

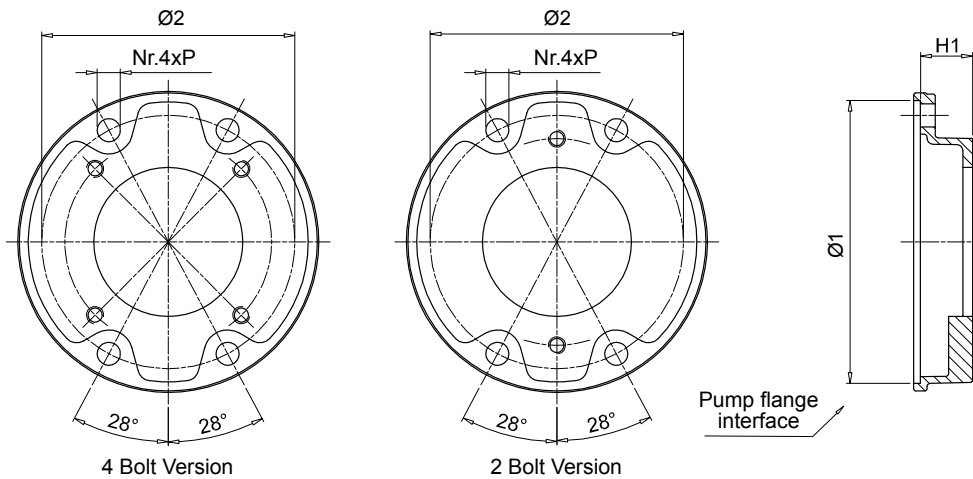

3

Pump flange code	H1	Ø1	Ø2	P	Mounting kit	Available pump interface		Weight [kg]
						2 Bolt	4 Bolt	
FP5026***	26				KVG5 See page 111	S023 - D042 - S063 - S070 - S072 S075	S024 - S024 - S033 - S125 - S154	1.0
FP5032***	32					-	S024 - S031 - S096 - S125	1.1
FP5035***	35					S023 - D042 - S063 - S070 - S072 - S075 - S060 - S072 - S074 - S075 - S106	S021 - S024 - S025 - S026 - S031 - S059 - S068 - S083 - S097 - S125 - S141	0.9
FP5045***	45					S060 - S070 - S071 - S072 - S074 - S075 - S106	S021 - S024 - S025 - S026 - S068 - S125 - S141	0.9
FP5056***	56	190	170	15		S072	S021 - S026	1.6
FP5063***	63					S070 - S079 - S138	S021 - S025 - S068 - S141	1.7
FP5091***	91					-	S025 - S031 - S033 - S113 - S267	2.2
FP6032***	32				KVG6 See page 111	S081 - S082	S021 - S035	1.8
FP6045***	45					S070 - S075 - S080 - S081 - S082	S021 - S025 - S026 - S027 - S069 - S077 - S125 - S198 - S207 - S215 - S253	2.1
FP6058***	58					S079 - S080 - S081 - S082	S025 - S026 - S027 - S038 - S077 - S078 - S207 - S215 - S237	2.4
FP6070***	70	240	218	17		S080	-	3.0
FP6082***	82					S080 - S081	S038 - S141 - 198 - 215	3.3
FP6086***	86					S090 - S092 - S166 - S091	S021 - S026 - S027 - S077 - S078 - S114 - S132 - 198 - S200	3.4
FP6101***	101					-	S027 - S035 - S113 - S132 - S148 - S176 - S228	4.2
FP6110***	110					S080	S111	5.5
FP7052***	52				KVG7 See page 111	-	S028 - S108 - S112 - S133 - S192	4.4
FP7066***	66					S090 - S092 - S166	-	4.8
FP7069***	69	288	258	22		-	S108 - S143 - S148 - S192 - S201 - S204 - S281 - S282	4.9
FP7086***	86					S091 - S092 - S117 - S166	S022 - S027 - S028 - S108 - S112 - S184 - S192 - S201 - S228 - S300	5.2
FP7111***	111					S091 - S092 - S117 - S145	S028 - S108 - S112 - S133 - S184	6.3

Pump flange code to be complete with available pump interface

Example: **FP6032S021**

Flange interface

Motor base interface

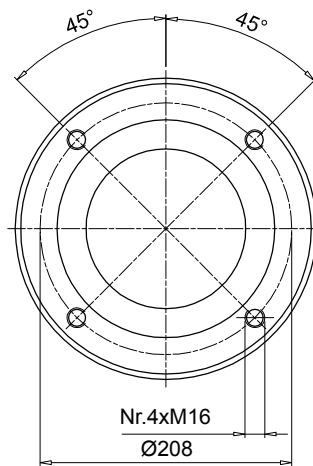
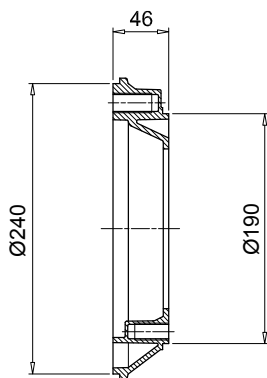
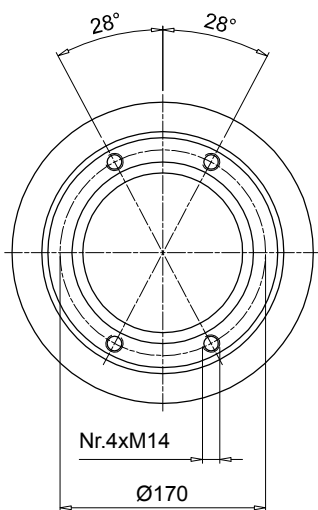

Code	Weight [kg]
AD60465	1.30

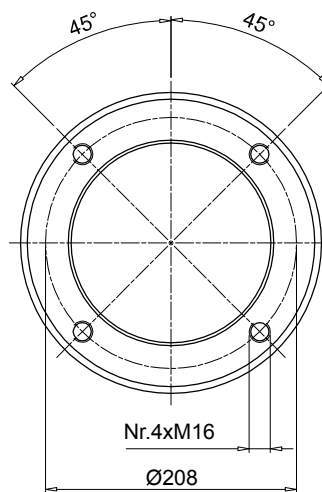
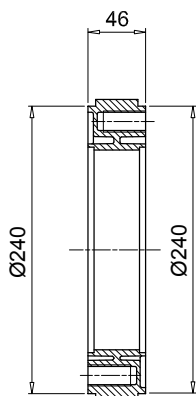
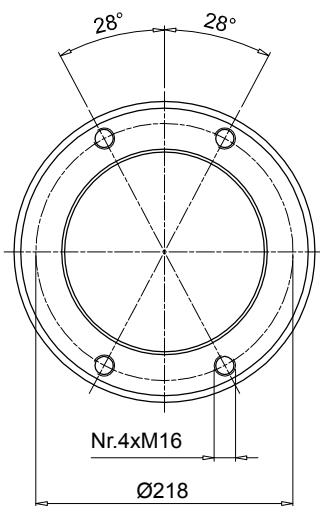

Code	Weight [kg]
AD60466	1.60

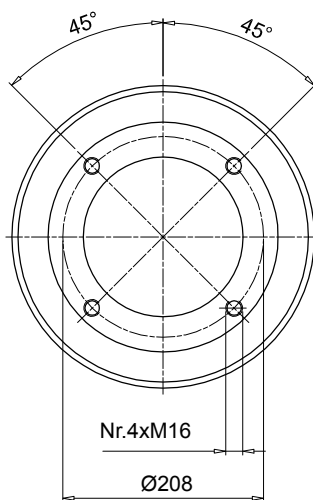
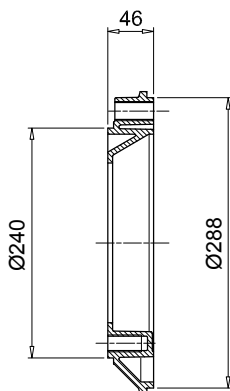
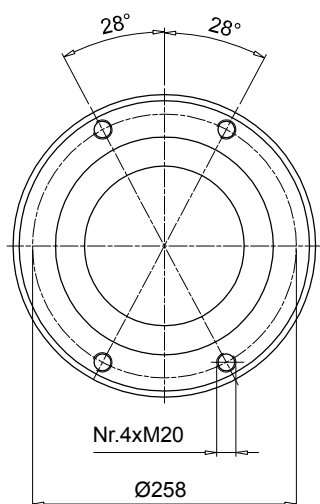

Code	Weight [kg]
AD60467	2.50

1

Inspection Hole
Plastic threaded plug mounted
(protection according
to DIN EN 292 part 2)
"Safety of machines"

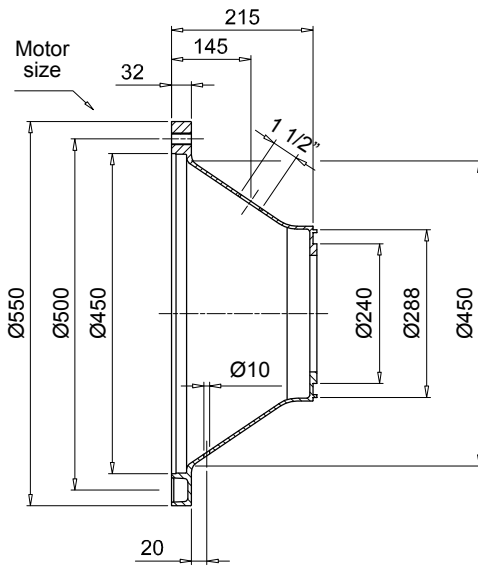
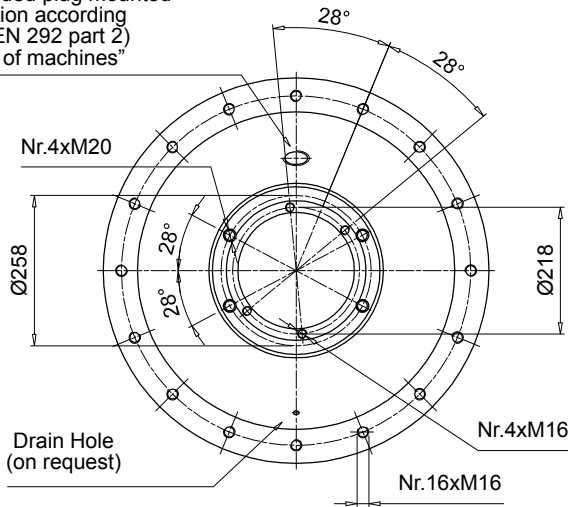

Motor base code	Weight [kg]
BMT550A21567	8.80

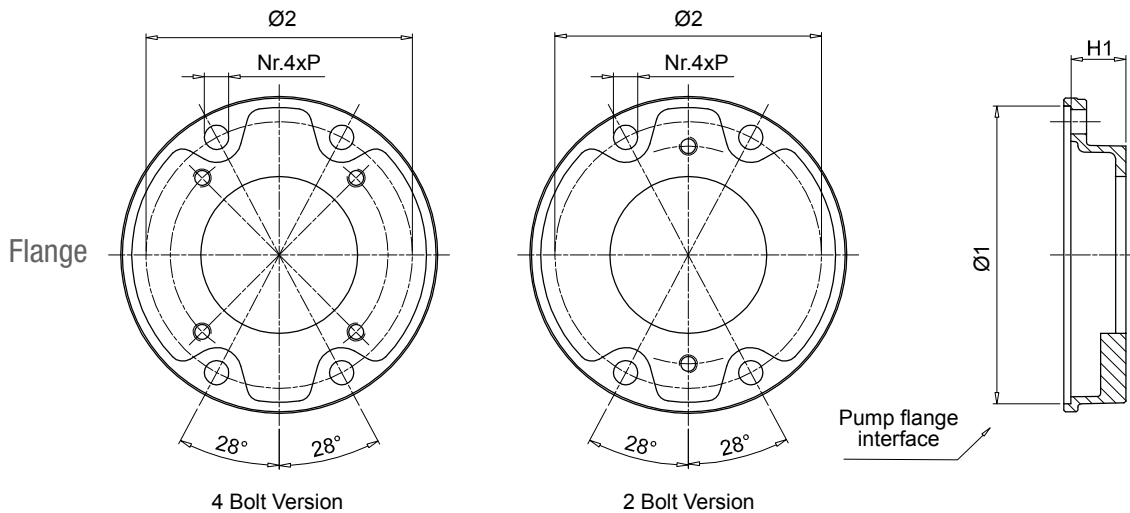

3

Pump flange code	H1	Ø1	Ø2	P	Mounting kit	Available pump interface		Weight [kg]	
						2 Bolt	4 Bolt		
FP6032***	32				KVG6 See page 111	S081 - S082	S021 - S035	1.8	
FP6045***	45					S070 - S075 - S080 - S081 - S082	S021 - S025 - S026 - S027 - S069 - S077 - S125 - S198 - S207 - S215 - S253	2.1	
FP6058***	58					S079 - S080 - S081 - S082	S025 - S026 - S027 - S038 - S077 - S078 - S207 - S215 - S237	2.4	
FP6070***	70	240	218	17		S080	-	-	3.0
FP6082***	82					S080 - S081	S038 - S141 - 198 - 215	-	3.3
FP6086***	86					S090 - S092 - S166 - S091	S021 - S026 - S027 - S077 - S078 - S114 - S132 - 198 - S200	-	3.4
FP6101***	101					-	S027 - S035 - S113 - S132 - S148 - S176 - S228	-	4.2
FP6110***	110				S080	S111	-	5.5	
FP7052***	52				KVG7 See page 111	-	S028 - S108 - S112 - S133 - S192	4.4	
FP7066***	66					S090 - S092 - S166	-	-	4.8
FP7069***	69	288	258	22		-	S108 - S143 - S148 - S192 - S201 - S204 - S281 - S282	-	4.9
FP7086***	86					S091 - S092 - S117 - S166	S022 - S027 - S028 - S108 - S112 - S184 - S192 - S201 - S228 - S300	-	5.2
FP7111***	111					S091 - S092 - S117 - S145	S028 - S108 - S112 - S133 - S184	-	6.3

Pump flange code to be complete with available pump interface

Example: **FP6032S021**

1

Inspection Hole
Plastic threaded plug mounted
(protection according
to DIN EN 292 part 2)
"Safety of machines"

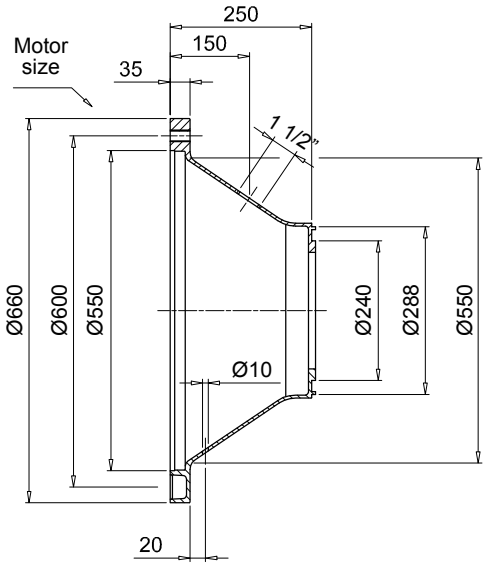
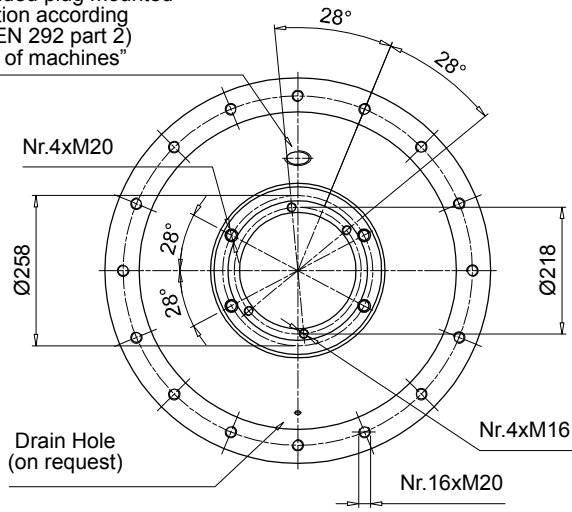

Motor base code	Weight [kg]
BMT660A25067	12.00

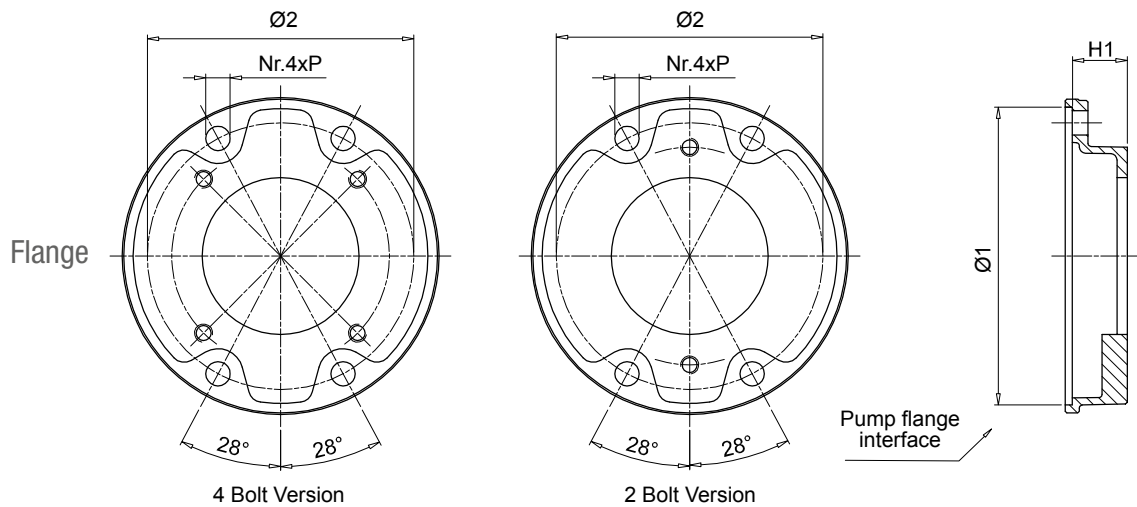

3

Pump flange code	H1	Ø1	Ø2	P	Mounting kit	Available pump interface		Weight [kg]
						2 Bolt	4 Bolt	
FP6032***	32	240	218	17	KVG6 See page 111	S081 - S082	S021 - S035	1.8
FP6045***	45					S070 - S075 - S080 - S081 - S082	S021 - S025 - S026 - S027 - S069 - S077 - S125 - S198 - S207 - S215 - S253	2.1
FP6058***	58					S079 - S080 - S081 - S082	S025 - S026 - S027 - S038 - S077 - S078 - S207 - S215 - S237	2.4
FP6070***	70					S080	-	3.0
FP6082***	82					S080 - S081	S038 - S141 - 198 - 215	3.3
FP6086***	86					S090 - S092 - S166 - S091	S021 - S026 - S027 - S077 - S078 - S114 - S132 - 198 - S200	3.4
FP6101***	101					-	S027 - S035 - S113 - S132 - S148 - S176 - S228	4.2
FP6110***	110	S080	S111	5.5				
FP7052***	52	288	258	22	KVG7 See page 111	-	S028 - S108 - S112 - S133 - S192	4.4
FP7066***	66					S090 - S092 - S166	-	4.8
FP7069***	69					-	S108 - S143 - S148 - S192 - S201 - S204 - S281 - S282	4.9
FP7086***	86					S091 - S092 - S117 - S166	S022 - S027 - S028 - S108 - S112 - S184 - S192 - S201 - S228 - S300	5.2
FP7111***	111					S091 - S092 - S117 - S145	S028 - S108 - S112 - S133 - S184	6.3

Pump flange code to be complete with available pump interface
Example: **FP6032S021**

1

Inspection Hole
Plastic threaded plug mounted
(protection according to
DIN EN 292 part 2)
"Safety of machines"

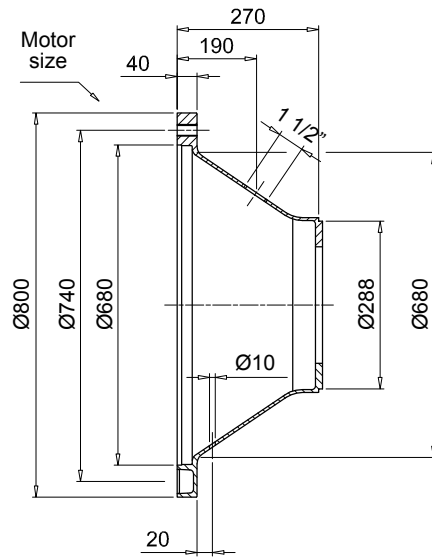
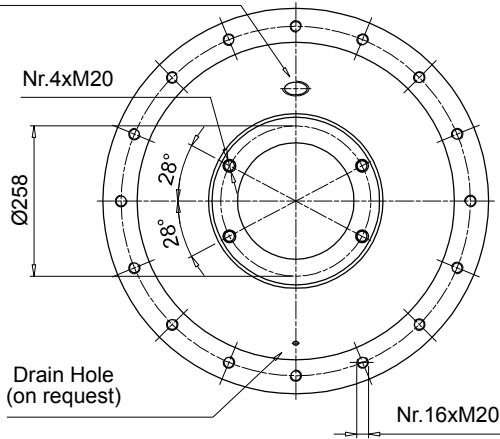

Motor base code	Weight [kg]
BAD800A2707	31.00

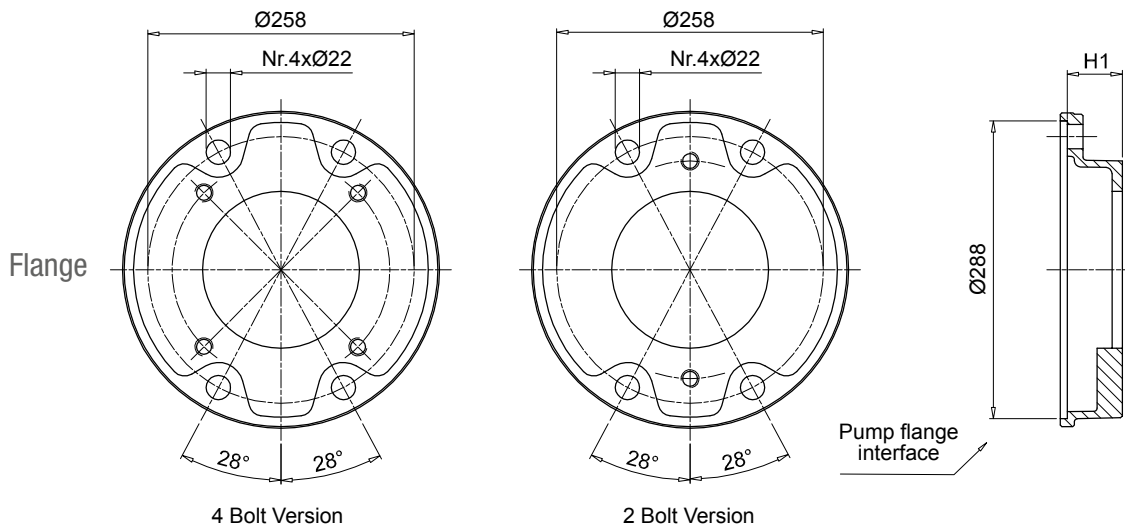

3

Pump flange code	H1	Ø1	Ø2	P	Mounting kit	Available pump interface		Weight [kg]
						2 Bolt	4 Bolt	
FP7052***	52				-	S028 - S108 - S112 - S133 - S192		4.4
FP7066***	66				KVG7	S090 - S092 - S166	-	4.8
FP7069***	69	288	258	22	See page 111	-	S108 - S143 - S148 - S192 - S201 - S204 - S281 - S282	4.9
FP7086***	86					S091 - S092 - S117 - S166 -	S022 - S027 - S028 - S108 - S112 - S184 - S192 - S201 - S228 - S300	5.2
FP7111***	111					S091 - S092 - S117 - S145	S028 - S108 - S112 - S133 - S184	6.3

Pump flange code to be complete with available pump interface
Example: **FP7052S028**

KVG1

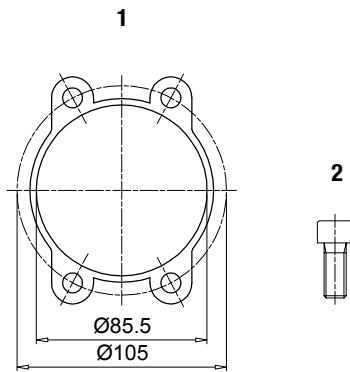

Components				
Item	Description	Q.ty	Material	Torque
1	Gasket for auxiliary flange FR1	1	Paper	-
2	Screw T.C.E.I. M8x20 UNI-5931 8.8	4	Steel	15 Nm

KVG5

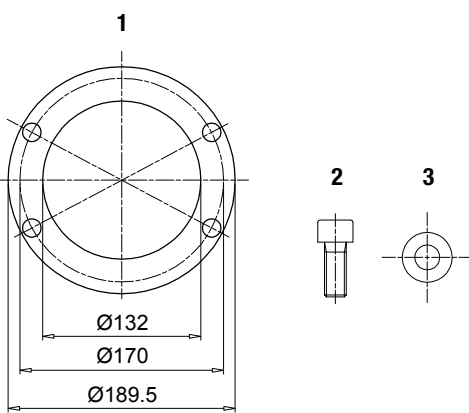

Components				
Item	Description	Q.ty	Material	Torque
1	Gasket for auxiliary flange FP5 / AD5	1	Paper	-
2	Screw T.C.E.I. M14x35 UNI-5931 8.8	4	Steel	90 Nm
3	Washer Schnorr 14	4	Steel	-

KVG6

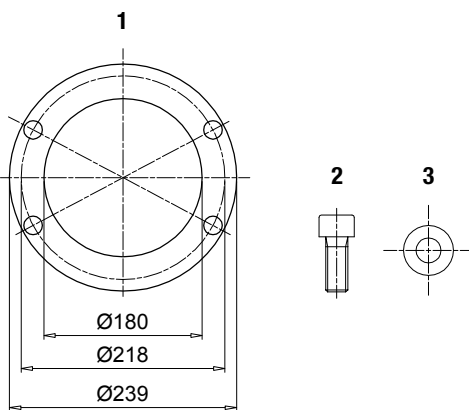

Components				
Item	Description	Q.ty	Material	Torque
1	Gasket for auxiliary flange FP6 / AD6	1	Paper	-
2	Screw T.C.E.I. M16x35 UNI-5931 8.8	4	Steel	130 Nm
3	Washer Schnorr 16	4	Steel	-

KVG7

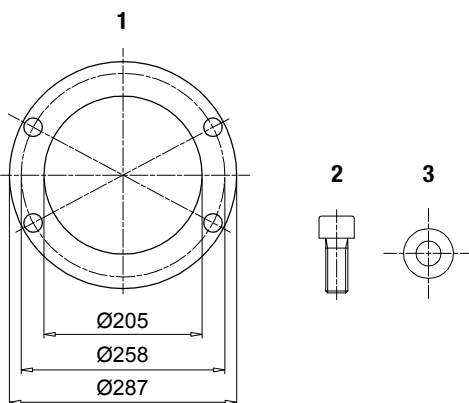

Components				
Item	Description	Q.ty	Material	Torque
1	Gasket for auxiliary flange FP7 / AD7	1	Paper	-
2	Screw T.C.E.I. M20x50 UNI-5931 8.8	4	Steel	200 Nm
3	Washer Schnorr 20	4	Steel	-

LME series

Engine power range from 3 to 13.5 HP



Technical data

Bell-housing - Engine power range from 3 to 13.5 HP

Materials

- Bell-housing: Pressure die casting Aluminium
- Gasket: Special paper - Guarnital

Versions:

- Single-drilled bell-housing for pump group 1 or 2, with pump centering ring included (see pages 116 - 117).
- Bell-housing with Multi -Drilling machined for group 1 and 2 pump, with pump centering ring to be ordered separately (see page 118).

Compatibility with fluids

Bell-housing components compatible for use with:

- Mineral oils types HH-HL-HM-HR-HV, to ISO 6743/4 standard
- Water based emulsions types HFAE-HFAS, to ISO 6743/4 standard
- Water glycol type HFC, to ISO 6743/4 standard: ask for anodized version

Special Applications

Any applications not covered by the normal indications contained in this catalogue must be evaluated and approved by MP Filtri Technical and Sales Department.

In order to ensure maximum reliability of the application, endothermic motor combinations include the exclusive use of elastic Spider made of Polyurethane 95 Shore A (see page 120).

Temperature

From -30 °C to +80 °C

Note

For temperatures outside this range, contact MP Filtri Technical and Sales Department

Our bell-housings are available for flanges standard according to the SAE standard.

Designation of pump flange and shaft

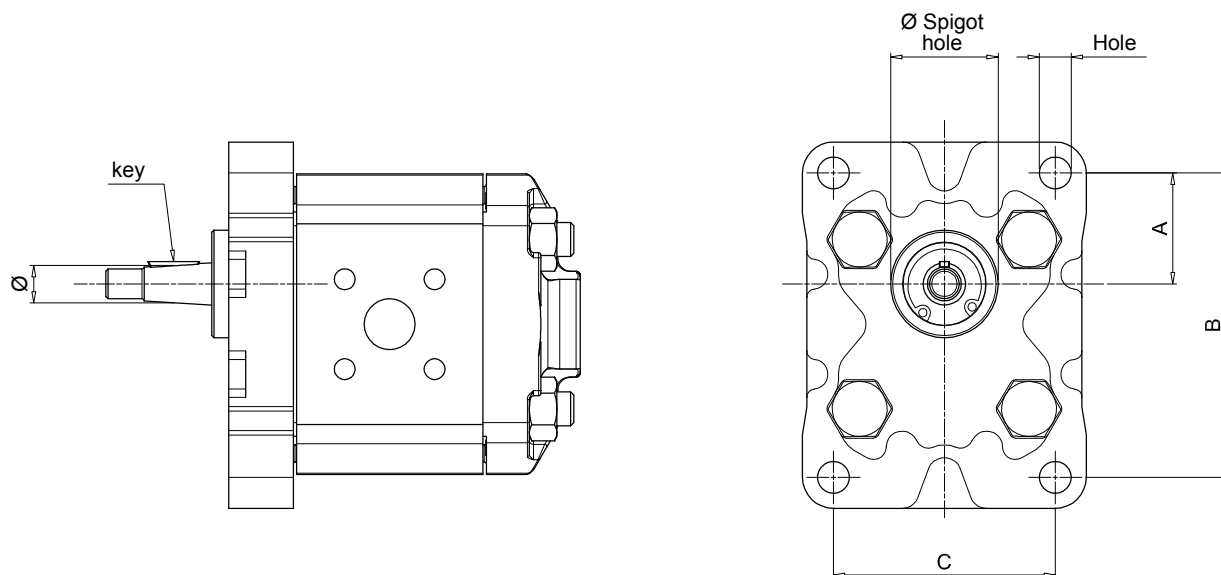

Pump group	Ø Spigot hole	Dimensions				Pump flange code	Ø	Key	Shaft type	Pump half-coupling code
		A	B	C	Hole					
05	22.0	25.5	66.0	-	M6	FS05M	6.0	2.0	parallel	FS05M
	22.0	25.5	66.0	-	M6	FS05C	7.0	2.0	parallel	FS05C
1	25.4	26.2	72.0	52.0	M6	FS100	9.7	2.4	tapered 1:8	FS100
	30.0	24.5	73.0	56.0	M6	FS1M0	12.0	3.0	parallel	FS1C0
	30.0	24.5	73.0	56.0	M6	FS1M0	13.9	3.0	tapered 1:8	FS1M0
2	36.5	32.5	96.0	71.5	M8	FS200	17.2	3.2 - 4	tapered 1:8	FS200

Dimensions

Combinations for Endothermic engine 3 - 5.5 Hp

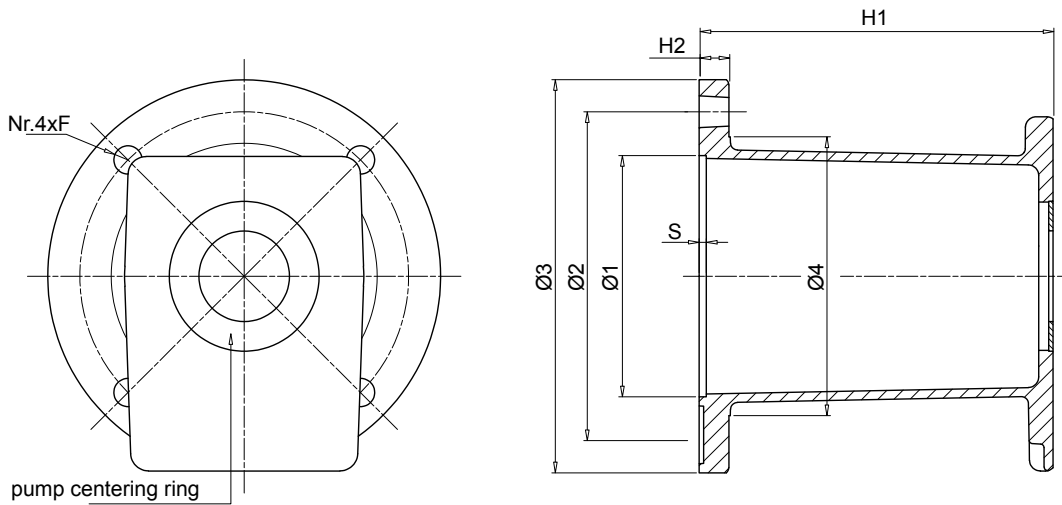

Dimensions [mm]								Weight [kg]
Ø1	Ø2	Ø3	Ø4	H1	H2	S	F	
67.5	92	110	78	99	8	3	8	0.5

Female centering Ø 67.5 - Gear pumps

Power Kw Hp		Shaft end	Pump code	Bell-Housing code	SG code motor side	Spider code	SG code pump side	Spigot hole
2.2-4	3-5.5	Ø 18 - Key 5 ISO 3019-2-E	FS100	LME110T099FS100	SGEA01C05056P10	EGE0RR	SGEA01FS100P10	ANCA002
			FS1M0	LME110T099FS1M0	SGEA01C05056P10	EGE0RR	SGEA01FS1M0P10	ANCA003
2.2-4	3-5.5	Ø 19.05 - Key 4.76 SAE straight shaft	FS100	LME110T099FS100	SGEA01G01056P10	EGE0RR	SGEA01FS100P10	ANCA002
			FS1M0	LME110T099FS1M0	SGEA01G01056P10	EGE0RR	SGEA01FS1M0P10	ANCA003

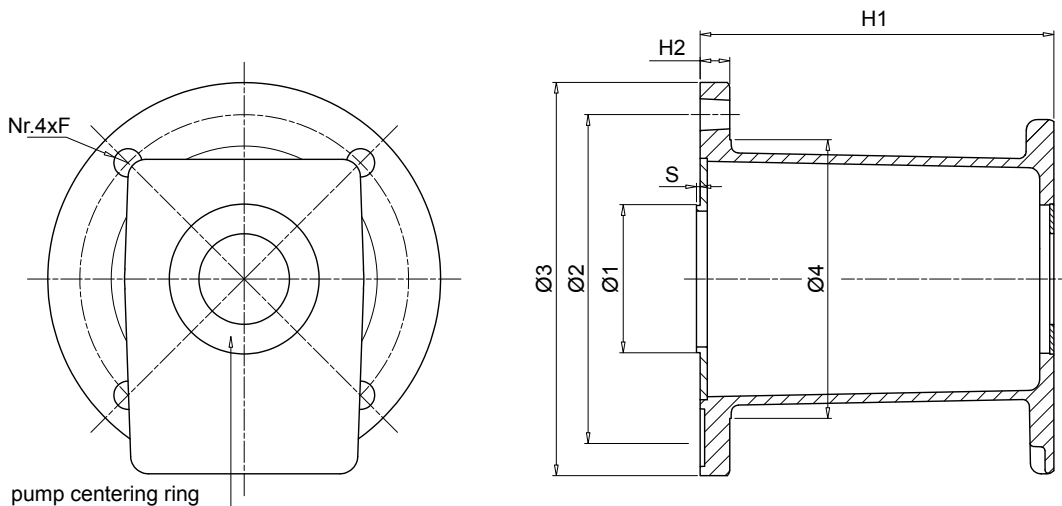

Dimensions [mm]								Weight [kg]
Ø1	Ø2	Ø3	Ø4	H1	H2	S	F	
41.2	92	110	78	99	8	3	8	0.5

Male centering ring Ø 41.2 - Gear pumps

Power Kw Hp		Shaft end	Pump code	Bell-Housing code	SG code motor side	Spider code	SG code pump side	Spigot hole
2.2-4	3-5.5	Ø 18 - Key 5 ISO 3019-2-E	FS100	LME110T099FS100MM	SGEA01C05056P10	EGE0RR	SGEA01FS100P10	ANCA002
			FS1M0	LME110T099FS1M0MM	SGEA01C05056P10	EGE0RR	SGEA01FS1M0P10	ANCA003
2.2-4	3-5.5	Ø 19.05 - Key 4.76 SAE straight shaft	FS100	LME110T099FS100MM	SGEA01G01056P10	EGE0RR	SGEA01FS100P10	ANCA002
			FS1M0	LME110T099FS1M0MM	SGEA01G01056P10	EGE0RR	SGEA01FS1M0P10	ANCA003

NOTE: Pump side centering rings are included in the bellhousing

Combinations for Endothermic engine 7 - 18 Hp

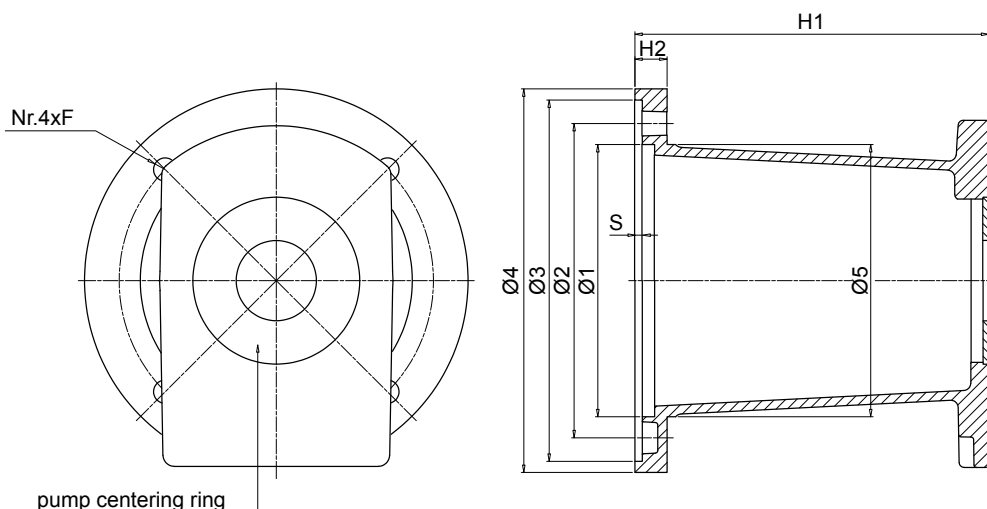

Dimensions [mm]									Weight [kg]
Ø1	Ø2	Ø3	Ø4	Ø5	H1	H2	S	F	
110	127	146	155	110	143	13	3	10	1.0

Gear pumps

Power Kw Hp		Shaft end	Pump code	Bell-Housing code	SG code motor side	Spider code	SG code pump side	Spigot hole
5-13.5	7-18	Ø 25 - Key 7 ISO 3019-2-E	FS100	LME155T140FS100	SGEA21E06076P10	EGE2RR	SGEA21FS100P10	ANCC002
			FS1C0	LME155T140FS1M0	SGEA21E06076P10	EGE2RR	SGEA21FS1C0P10	ANCC003
			FS1M0	LME155T140FS1M0	SGEA21E06076P10	EGE2RR	SGEA21FS1M0P10	ANCC003
			FS200	LME155T140FS200	SGEA21E06076P10	EGE2RR	SGEA21FS200P10	ANCC004
		Ø 25.4 - Key 6.35 SAE straight shaft	FS100	LME155T140FS100	SGEA21G040762FP10	EGE2RR	SGEA21FS100P10	ANCC002
			FS1C0	LME155T140FS1M0	SGEA21G040762FP10	EGE2RR	SGEA21FS1C0P10	ANCC003
			FS1M0	LME155T140FS1M0	SGEA21G040762FP10	EGE2RR	SGEA21FS1M0P10	ANCC003
			FS200	LME155T140FS200	SGEA21G040762FP10	EGE2RR	SGEA21FS200P10	ANCC004

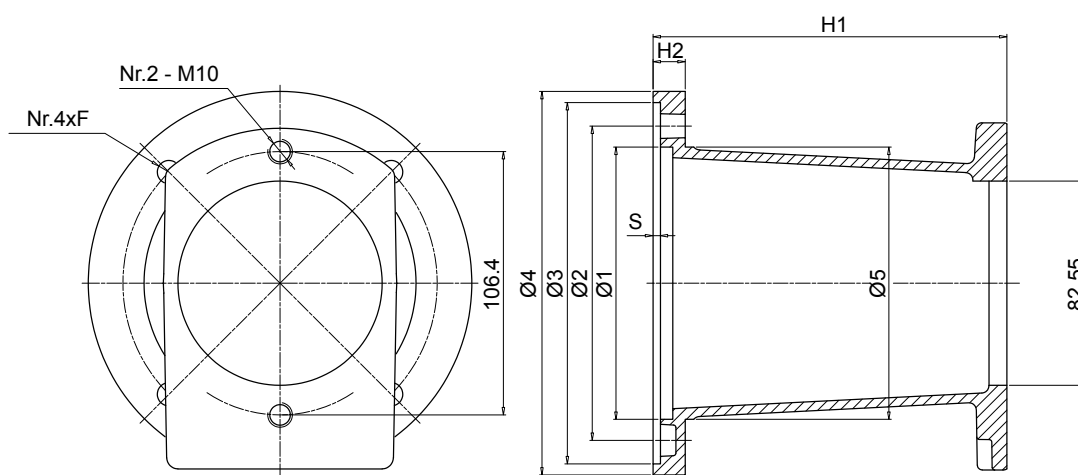

Dimensions[mm]									Weight [kg]
Ø1	Ø2	Ø3	Ø4	Ø5	H1	H2	S	F	
110	127	146	155	110	143	13	3	10	1.0

Pump SAE A 2 BOLT

Power Kw Hp		Shaft end	Pump code	Bell-Housing code	SG code motor side	Spider code	SG code pump side	Spigot hole
5-13.5	7-18	Ø 25 - Key 7 ISO 3019-2-E	SAE A 2 BOLT	LME155T140S060	SGEA21E06076P10	EGE2RR	SGEA21G01030P10	-
		Ø 25.4 - Key 6.35 SAE straight shaft	SAE A 2 BOLT	LME155T140S060	SGEA21G040762FP10	EGE2RR	SGEA21G01030P10	-

NOTE: Pump side centering rings are included in the bellhousing

Dimensions

Combinations for Endothermic engine 7 - 18 Hp

BELL-HOUSING MULTI-DRILLING FOR GROUP 1 AND 2

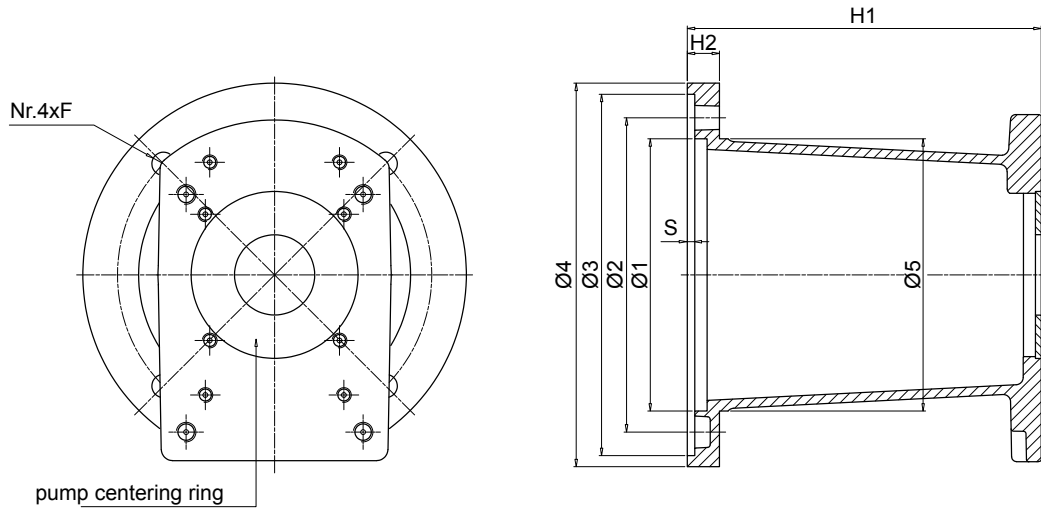

Dimensions [mm]										Weight [kg]
Ø1	Ø2	Ø3	Ø4	Ø5	H1	H2	S	F		
110	127	146	155	110	143	13	3	10		1.0

Gear pumps

Power Kw	Power Hp	Shaft end	Pump code	Bell-Housing code	SG code motor side	Spider code	SG code pump side	Spigot hole
5-13.5	7-18	Ø 25 - Key 7 ISO 3019-2-E	FS100 +	LME155T140FS100M3	SGEA21E06076P10	EGE2RR	SGEA21FS100P10	ANCC002
			FS1C0 +	LME155T140FS100M3	SGEA21E06076P10	EGE2RR	SGEA21FS1C0P10	ANCC003
			FS1M0 +	LME155T140FS100M3	SGEA21E06076P10	EGE2RR	SGEA21FS1M0P10	ANCC003
			FS200	LME155T140FS100M3	SGEA21E06076P10	EGE2RR	SGEA21FS200P10	ANCC004
		Ø 25.4 - Key 6.35 SAE straight shaft	FS100 +	LME155T140FS100M3	SGEA21G040762FP10	EGE2RR	SGEA21FS100P10	ANCC002
			FS1C0 +	LME155T140FS100M3	SGEA21G040762FP10	EGE2RR	SGEA21FS1C0P10	ANCC003
			FS1M0 +	LME155T140FS100M3	SGEA21G040762FP10	EGE2RR	SGEA21FS1M0P10	ANCC003
			FS200	LME155T140FS100M3	SGEA21G040762FP10	EGE2RR	SGEA21FS200P10	ANCC004

NOTE: Pump side centering rings are not included in the bellhousing

Motor half-coupling

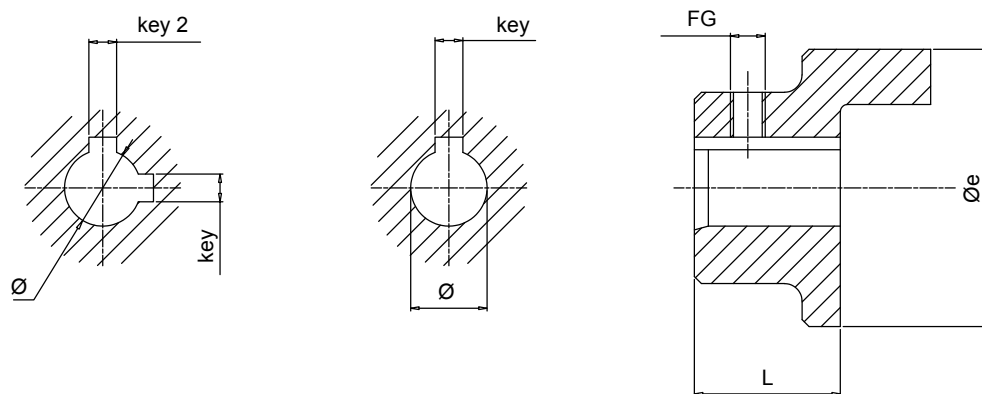

Half-coupling code	Dimensions [mm]						Weight [kg]
	Øe	L	Ø	Key	Key 2	FG	
SGEA01C05056P10	40	56	18.00	5.00	6.00	M5	0.13
SGEA01G01056P10	40	56	19.05	4.76	-	M5	0.13
SGEA21E06076P10	65	76	25.00	7.00	-	M6	0.35
SGEA21G040762FP10	65	76	25.40	4.76	6.35	M6	0.35

NOTE: Double key version pump side only

Half-coupling for gear pumps

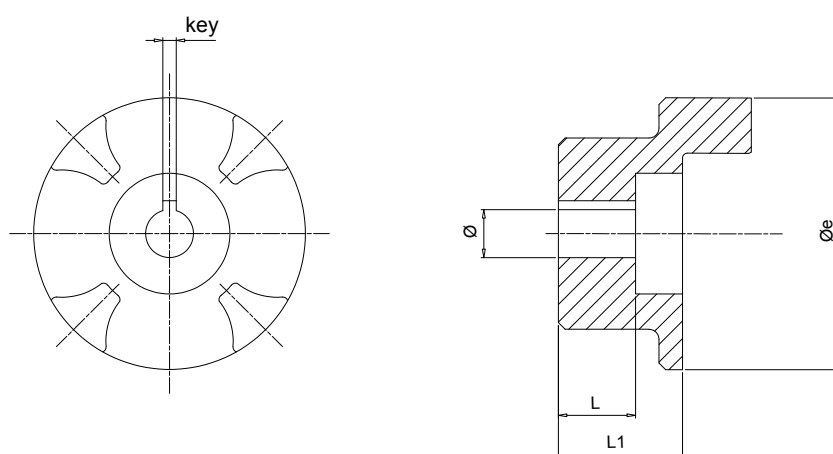

Half-coupling code	Dimensions [mm]						Weight [kg]
	Øe	L	L1	Ø	Key		
SGEA01FS05CP10	40	10.0	17.0	7	2	0.08	
SGEA01FS1COP10	40	-	17.0	12	3	0.13	
SGEA21FS1COP10	65	14.5	21.5	12	3	0.48	

Dimensions

Half-coupling for gear pumps

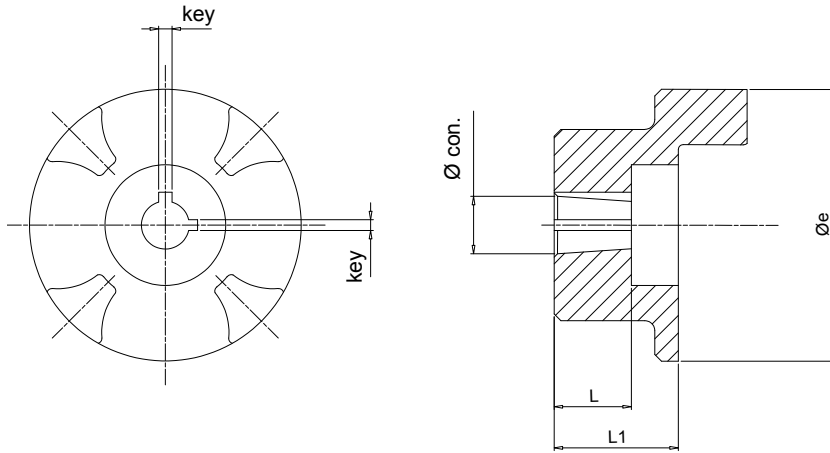

Half-coupling code	Øe	L	Dimensions [mm]			Key	Weight [kg]	Tapered
			L1	Ø				
SGEA01FS100P10	40	14.5	16.0	9.7	2.4	0.12	1:8	
SGEA01FS1MOP10	40	16.0	16.0	13.9	3.0	0.30	1:8	
SGEA21FS100P10	65	14.5	21.5	9.7	2.4	0.33	1:8	
SGEA21FS1MOP10	65	18.5	21.5	13.9	3.0	0.78	1:8	
SGEA21FS200P10	65	21.5	21.5	17.2	3.2 - 4	1.60	1:8	

Spider EGE**RR series

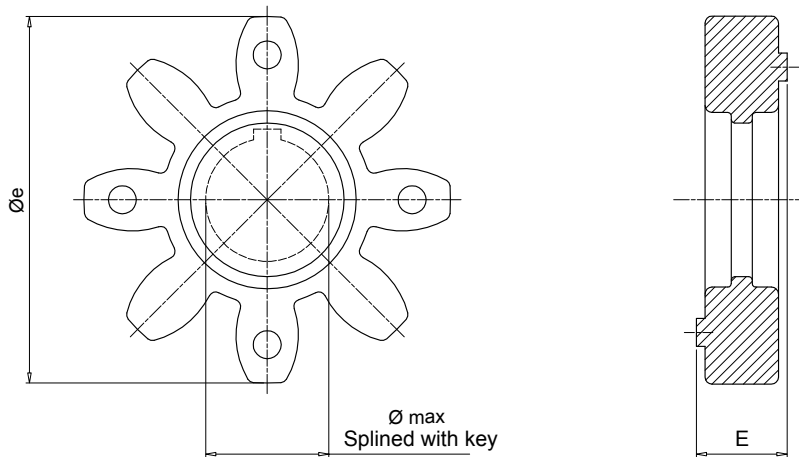

Notes:

Made in polyurethane Laripur LPR202-95A, red colour, are suitable for applications where high levels of torque are transmitted.

Code	Half-coupling code	E	Dimensions [mm]			Nominal torque Nm	Max torque Nm	Weight [kg]
			Øe	Ø max				
EGE0RR	SGEA01	15	40	16	15	30	0.006	
EGE2RR	SGEA21	18	65	25	115	230	0.02	

Version for extreme temperatures available on request.
For further information, contact MP Filtri Technical and Sales Department.

Pump centering ring

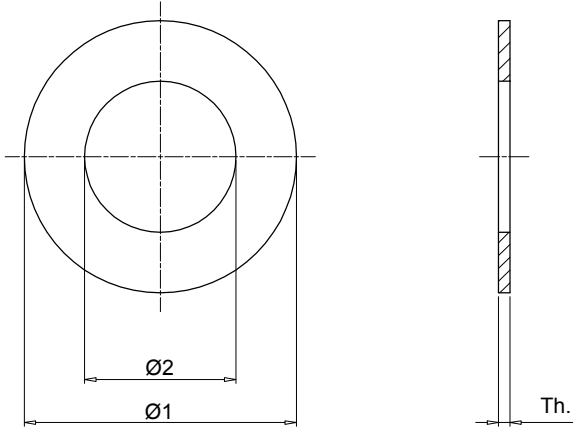

Pump centering ring code	Dimensions [mm]		
	Ø1	Ø2	Sp.
ANCA002	50	25.4	1.0
ANCA003	50	30.0	1.0
ANCC002	67.5	25.4	2.0
ANCC003	67.5	30.0	2.0
ANCC004	67.5	36.5	2.0

Designation & Ordering code

COMPLETE KIT (BELL-HOUSING & COUPLINGS)

Configuration example: **AKA155** **G04** **FS200** **P10**

Endothermic engine identification code	
110	3 - 5.5 Hp
155	5.5 - 13.5 Hp

Shaft end codes	
C05	Ø18-Ch.5
G01	Ø19.05-Ch.4.76
E06	Ø25-Ch.7
G04	Ø25.4-Ch.4.76/6.35

Pump interface codes	
FS100	Gr. 1
FS1M0	Gr. 1M
FS200	Gr. 2
SAE A	2 BOLT

The range of products is completed by a number of accessories, including:

DAMPING RINGS, intended mainly for use with motor-pump units positioned vertically and with the pump submerged in the oil tank.

FOOT BRACKETS, which serve to support the motor pump unit in the event that the selected electric motor does not have mounting feet.

DAMPING RODS, to be mounted under the electric motor feet or under the foot brackets.

CLEANING COVERS, facilitating the maintenance of oil tanks in hydraulic power units, without necessarily having to dismantle the unit.

ALUMINIUM TANKS of 10 litres capacity, allowing the assembly of a compact hydraulic power unit.

Accessories



ANM A	Damping rings	page 124
PDM A	Foot brackets	126
MPDR PDMA - MPDR	Damping rods	127
OB	Cleaning covers	128
SE10	Aluminium tanks	133

Technical data

Positioned between the bell-housing motor flange and lid of the tank, they help to reduce the transmission of the vibrations and emission of noise generated by the system.

Damping rings provide a perfect hydraulic sealing actions by virtue of their special profile; damping rings are available for IEC electric motors from size 80 to size 315.

Compatibility with fluids

- Mineral oils types HH-HL-HM-HR-HV, to ISO 6743/4 standard
- Water based emulsions types HFAE-HFAS, to ISO 6743/4 standard

Materials

Internal ring: pressure die-cast aluminium alloy
External body: NBR 75 Shore A

Temperature

From -30 °C to +80 °C

Special Applications

Any applications not covered by the normal indications contained in this catalogue must be evaluated and approved by MP Filtri Technical and Sales Department

Example of assembly

In order to warranty the application, to proceed with the calculation of the max weight and moment with the following formulas.

Values higher than those in the table could damage the product and couldn't warranty the conformity of the application!

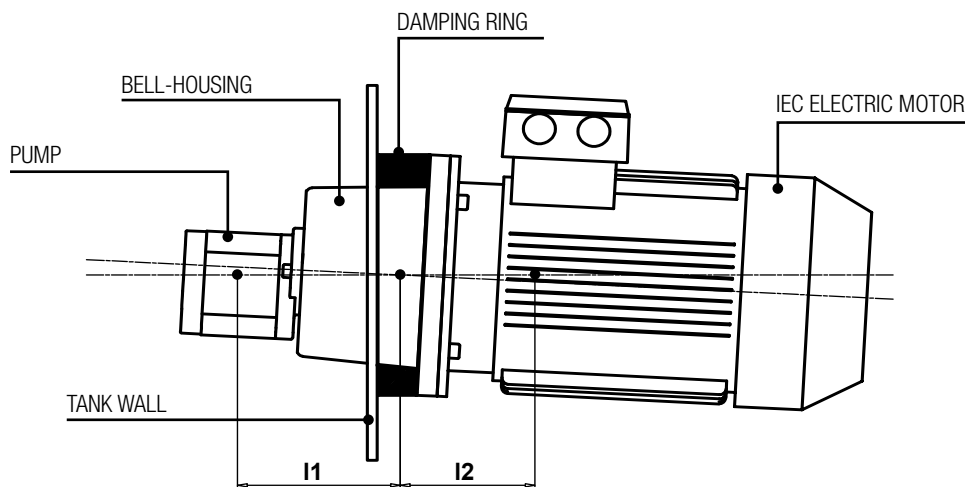

$$F_{perm} \geq F_p + F_m$$

$$M_b perm \geq F_m \times l_1 - F_p \times l_2$$

Permissible radial weight and bending load for damping rings

Code	F perm [N]	Mb perm [N·m]
ANM A 200	370	30
ANM A 250	720	65
ANM A 300	1450	175
ANM A 350	3600	740
ANM A 400	4800	1100
ANM A 450	6600	1600
ANM A 550	13000	4400
ANM A 660	24000	9000

Legend of symbol

- F perm** = ammissible load (N)
- Fp** = pumps weight (N)
- Fm** = motor weight (N)
- Mb perm** = bending load (N·m)

ANM A 200 ÷ 400

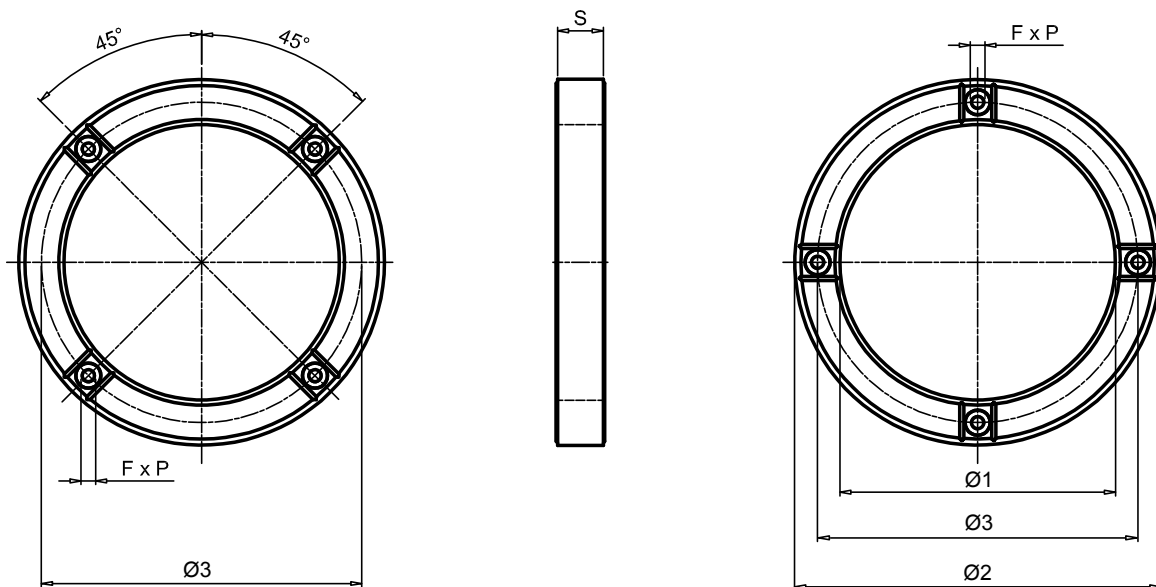

Code	IEC - Electric motors	Dimensions [mm]					Nr. F	Screw tightening torque [N·m]	Weight [kg]
		Ø1	Ø2	Ø3	S	F x P			
ANM A 200	80, 90S / 90L	144	200	165	40	M10x16	4+4	23	1.70
ANM A 250	100L / 112M	191	250	215	45	M12x16		40	2.53
ANM A 300	132S / 132M	238	300	265	50	M12x16		40	2.15
ANM A 350	160L/160M, 180L/180M	260	350	300	58	M16x20		100	3.95
ANM A 400	200L	301	400	350	50	M16x25		100	4.60

ANM A 450 ÷ 660

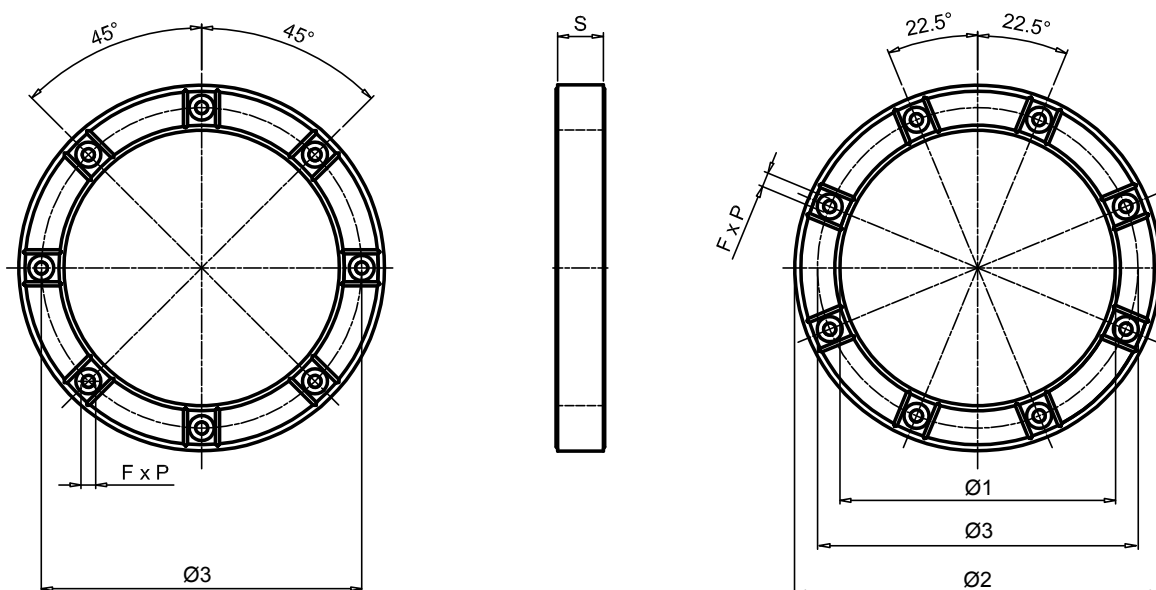

Code	IEC - Electric motors	Dimensions [mm]					Nr. F	Screw tightening torque [N·m]	Weight [kg]
		Ø1	Ø2	Ø3	S	F x P			
ANM A 450	225S / 225M	352	450	400	60	M16x25	8+8	100	6.20
ANM A 550	250M, 280M / 280S	452	550	500	60	M16x25		210	7.76
ANM A 660	315M / 315S	552	660	600	67	M20x25		410	11.25

Technical data

The foot brackets are proportioned to support IEC Electric motors with B5 flange without feet.

The range is available from size 71 to size 180.

Compatibility with fluids

- Mineral oils types HH-HL-HM-HR-HV, to ISO 6743/4 standard
- Water based emulsions types HFAE-HFAS, to ISO 6743/4 standard
- Water glycol type HFC, to ISO 6743/4 standard: ask for anodized version

Materials

Foot bracket: pressure die-cast aluminium alloy

Temperature

From -30 °C to +80 °C

Dimensions

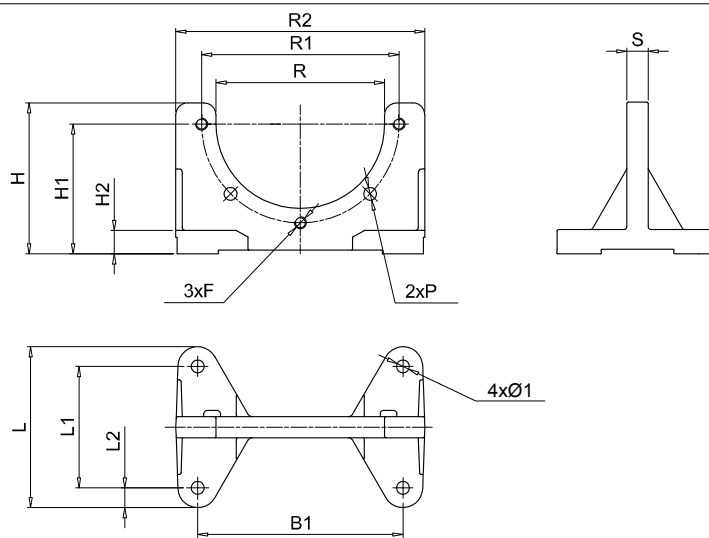

Foot bracket	Dimensions [mm]															Weight [kg]
	B	B1	R2	L	L1	L2	H	H1	H2	R	R1	S	P	Ø1	F	
PDM A 160	160	135	180	106	80	13	100	86	16	111	130	14	8.5	8.5	M8	0.45
PDM A 200	200	175	207	128	98	21	128	115	14	146	165	14	11.0	11.5	M10	0.60
PDM A 250	250	220	262	172	130	21	157	145	18	191	215	16	13.0	13.5	M12	1.20
PDM A 300	300	270	320	210	160	25	188	170	18	235	265	20	13.0	13.5	M12	1.80

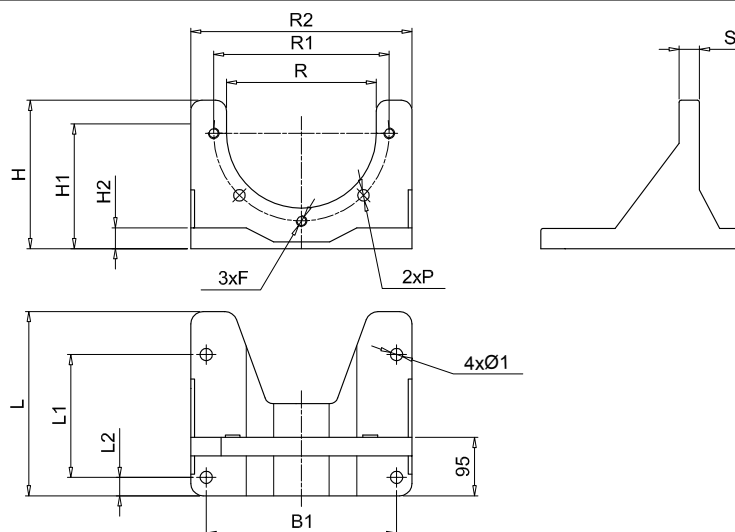

Foot bracket	Dimensions [mm]															Weight [kg]
	B	B1	R2	L	L1	L2	H	H1	H2	R	R1	S	P	Ø1	F	
PDM A 350	350	310	360	300	200	30	220	200	30	261	300	30	18	13	M16	4.80

Damping rods are element to reduce the transmission of the vibrations and emission of noise generated of the system.

Damping rods are available for IEC Electric motors from size 71 to size 315L and for MP FILTRI foot bracket

Compatibility with fluids

- Mineral oils types HH-HL-HM-HR-HV, to ISO 6743/4 standard
- Water based emulsions types HFAE-HFAS, to ISO 6743/4 standard

Materials

Plate: steel black colour
Damping element: NBR 60 Shore A

Temperature

From -20 °C to +80 °C

Special Applications

Any applications not covered by the normal indications contained in this catalogue must be evaluated and approved by the MP Filtri Technical and Sales Department

Dimensions

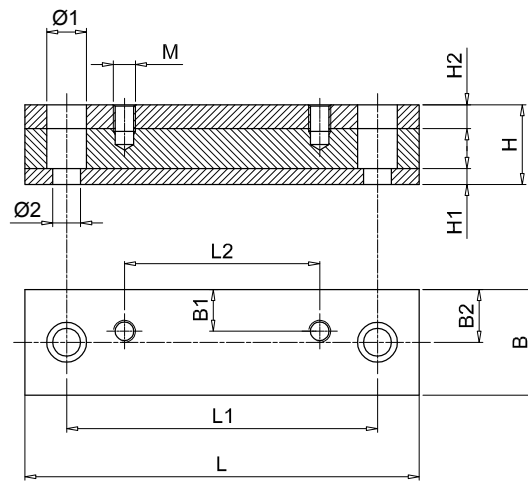

Damping rods for foot brackets PDMA series.

For foot brackets see page 116

Code	Dimensions [mm]											Weight [kg]	
	L	L1	L2	B	B1	B2	H	H1	H2	Ø1	Ø2		M
MPDR PDMA160P	196	156	80	50	21	25	40	8	12	20	14	M8	1.5
MPDR PDMA200P	196	156	98	50	21	25	40	8	12	20	14	M10	1.5
MPDR PDMA250P	240	205	130	50	24	25	40	8	12	20	14	M12	2.0
MPDR PDMA300P	280	245	160	50	20	25	45	8	12	20	14	M12	2.5
MPDR PDMA350P	446	400	200	70	35	35	60	15	15	26	18	M12	8.0

Damping rods for electrical motors UNEL-MEC

Code	Dimensions [mm]											Weight [kg]	
	L	L1	L2	B	B1	B2	H	H1	H2	Ø1	Ø2		M
MPDR 71P	196	156	90	50	21	25	40	8	12	20	14	M6	1.5
MPDR 80P	176	146	100	50	22	25	40	8	12	20	14	M8	1.7
MPDR 90SP	196	156	100	50	24.5	25	40	8	12	20	14	M8	1.7
MPDR 90LP	240	205	125	50	24	25	40	8	12	20	14	M8	2.0
MPDR 100LP	240	205	140	50	22	25	40	8	12	20	14	M10	2.0
MPDR 132SP	280	245	140	50	20	25	45	8	12	20	14	M10	2.5
MPDR 132MP	280	245	178	50	20	25	45	8	12	20	14	M10	2.5
MPDR 160MP	340	300	210	70	28	35	60	15	15	26	18	M12	6.0
MPDR 160LP	416	370	254	70	28	35	60	15	15	26	18	M12	7.5
MPDR 180MP	416	370	241	70	35	35	60	15	15	26	18	M12	7.5
MPDR 180LP	446	400	279	70	35	35	60	15	15	26	18	M12	8.0
MPDR 200LP	492	430	305	70	35	35	60	15	15	33	22	M16	8.9
MPDR 225SP	492	430	286	70	35	35	60	15	15	33	22	M16	8.9
MPDR 225MP	492	445	311	70	35	35	60	15	15	33	22	M16	8.9
MPDR 250MP	492	445	349	100	50	50	60	15	15	33	22	M20	12.5
MPDR 280SP	614	570	368	100	50	50	60	15	15	33	22	M20	15.1
MPDR 280MP	614	570	419	100	50	50	60	15	15	33	22	M20	15.1
MPDR 315SP	614	570	406	120	60	60	60	15	15	33	22	M24	26.5
MPDR 315MP	614	570	457	120	60	60	60	15	15	33	22	M24	26.5
MPDR 315LP	704	660	508	120	60	60	60	15	15	33	22	M24	29.2

Technical data

These pressure die-cast aluminium alloy doors offer superior mechanical strength and are manufactured to DIN 24339 standard. They provide easy access to the inside of the oil tank for inspection and cleaning purposes.

On request and for small quantities, to be agreed with MP Filtri Technical and Sales Department, inspection doors can be supplied with:

- Customer logo.
- Hole cut for visual level indicator.
- Hole cut for visual and electrical level indicator.
- Oil sample plug

Compatibility with fluids

- Mineral oils types HH-HL-HM-HR-HV, to ISO 6743/4 standard
- Water based emulsions types HFAE-HFAS, to ISO 6743/4 standard
- Water glycol type HFC, to ISO 6743/4 standard: ask for anodized version

Materials

Cleaning covers: pressure die-cast aluminium alloy

Seal: NBR 70 Shore A

Temperature

From -30 °C to +80 °C

Special Applications

Any applications not covered by the normal indications contained in this catalogue must be evaluated and approved by MP Filtri Technical and Sales Department

Dimensions

Cleaning cover according to DIN 24339

OB275

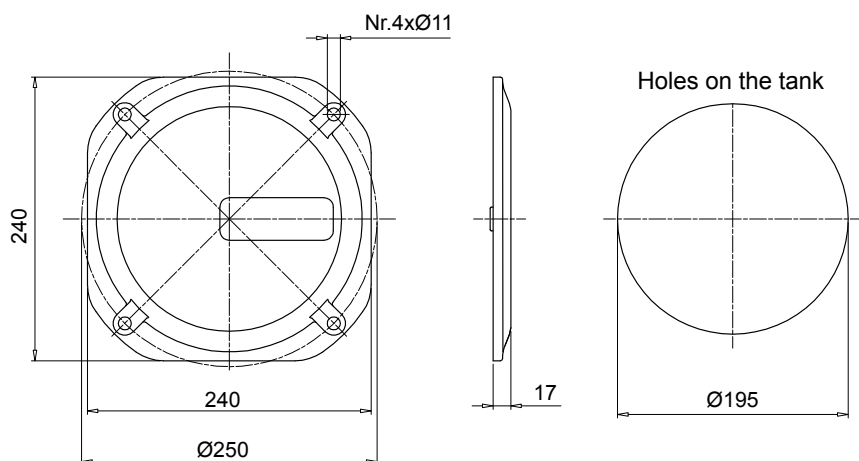

Code	Description	Seal	Weight [kg]
OB275P01GN	Door with MP Logo	NBR	2.06
OB275P02GN	Blank cover	NBR	2.06
OB275P01GV	Door with MP Logo	FPM	2.06
OB275P02GV	Blank cover	FPM	2.06

Code	Description	Weight [kg]
OB275P01	Door with MP Logo	1.76
OB275P02	Blank cover	1.76
GU0275NBR	Seal	1.76
GU0275VTN	Seal	1.76

OB400

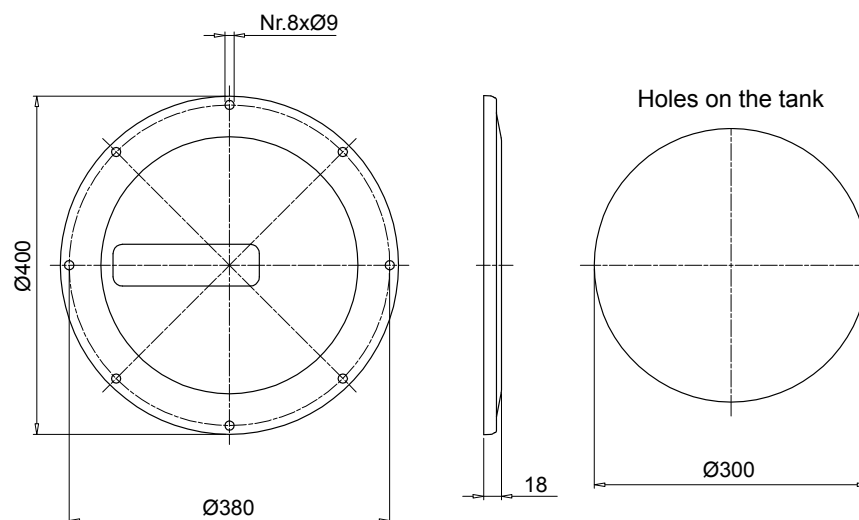

Code	Description	Seal	Weight [kg]
OB400P01GN	Door with MP Logo	NBR	3.20
OB400P02GN	Blank cover	NBR	3.20
OB400P01GV	Door with MP Logo	FPM	3.20
OB400P02GV	Blank cover	FPM	3.20

Code	Description	Weight [kg]
OB400P01	Door with MP Logo	2.90
OB400P02	Blank cover	2.90
GU0400NBR	Seal	2.90
GU0400VTN	Seal	2.90

OB350

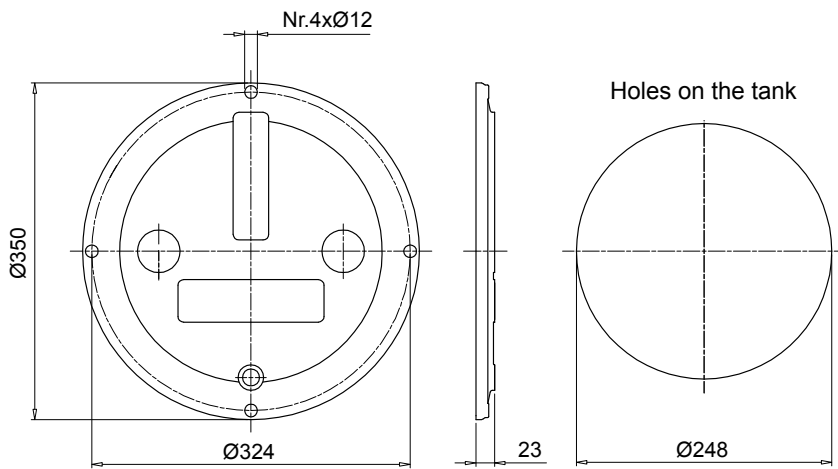

Code	Description	Seal	Weight [kg]
OB350P01GN	Door with MP Logo	NBR	2.10
OB350P02GN	Blank cover	NBR	2.10
OB350P01GV	Door with MP Logo	FPM	2.10
OB350P02GV	Blank cover	FPM	2.10

Code	Description	Weight [kg]
OB350DIN000	Door	1.80
GU0350DINNBR	Seal	1.80
GU0350DINVTN	Seal	1.80

OB356

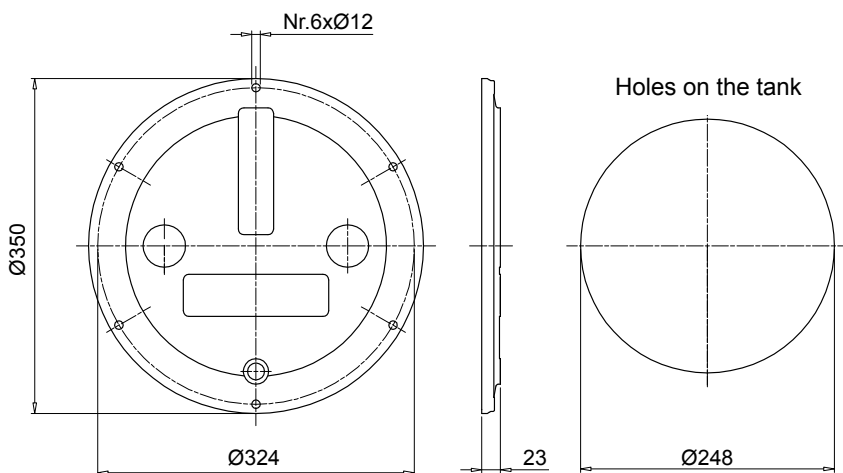

Code	Description	Seal	Weight [kg]
OB356P01GN	Door with MP Logo	NBR	2.10
OB356P02GN	Blank cover	NBR	2.10
OB356P01GV	Door with MP Logo	FPM	2.10
OB356P02GV	Blank cover	FPM	2.10

Code	Description	Weight [kg]
OB356DIN000	Door	1.80
GU0350DINNBR	Seal	1.80
GU0350DINVTN	Seal	1.80

OB475

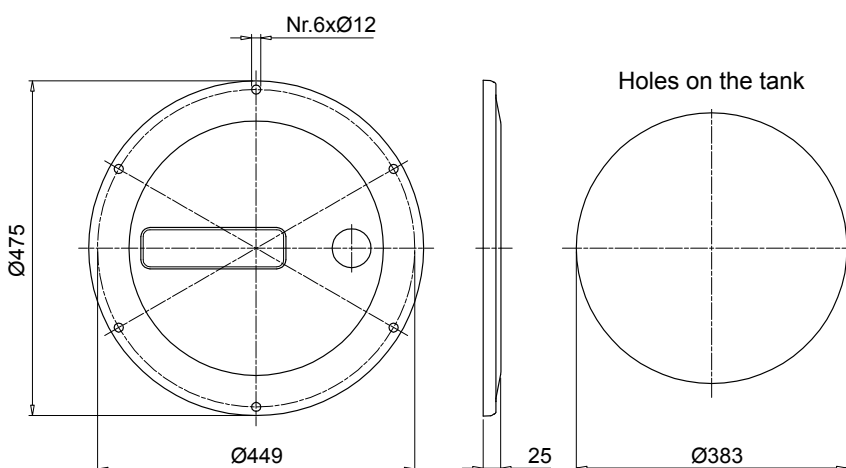

Code	Description	Seal	Weight [kg]
OB475P01GN	Door with MP Logo	NBR	3.70
OB475P02GN	Blank cover	NBR	3.70
OB475P01GV	Door with MP Logo	FPM	3.70
OB475P02GV	Blank cover	FPM	3.70

Code	Description	Weight [kg]
OB475P01	Door with MP Logo	3.40
OB475P02	Blank cover	3.40
GU0475DINNBR	Seal	3.40
GU0475DINVTN	Seal	3.40

Oil level indicator **LVA** series - vertical shape

Technical data

Materials

Transparent amorphous polyamide lens
Polyamide guard
Seals: NBR - FPM

Operating pressure

Max 1 bar at +80°C

Operating temperature

From -25 °C to +80 °C

Tightening torque

10 N·m max.

Mineral oils
Synthetic oils
Water base emulsions
Phosphoric esters

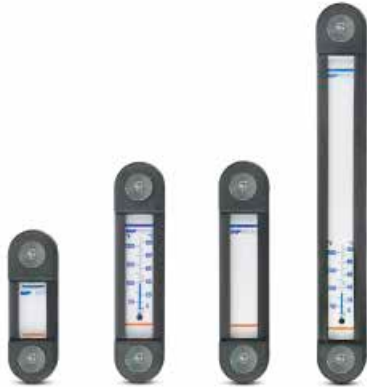

Installation

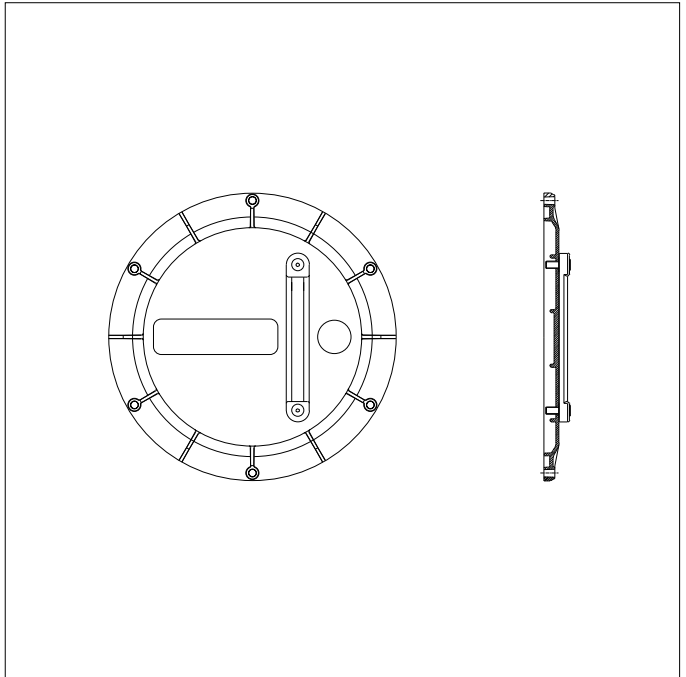

Dimensions

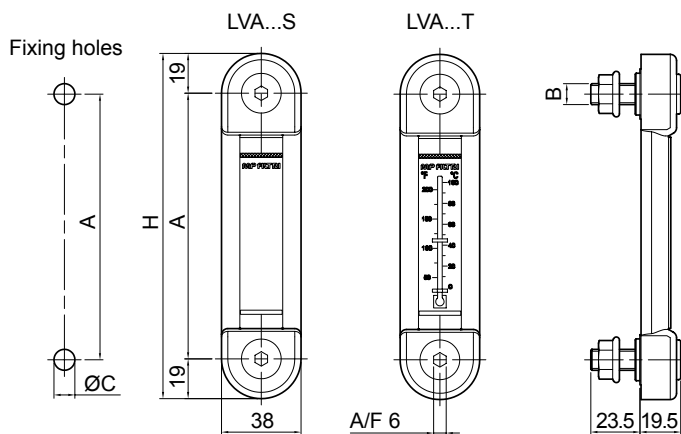

Size	A [mm]	H [mm]
LVA 10	76	114
LVA 20	127	165
LVA 30	254	292

Type	B [mm]	ØC [mm]
LVA...M10	M10	10.5
LVA...M12	M12	12.5
LVA...U38	3/8" UNC	10.0
LVA...U12	1/2" UNC	13.5

Packaging

Type	Nr. pieces per pack
LVA	10

Preparing for to fit the level on request

Indicator code	OB275**	OB350**	OB356**	OB400**	OB475**
LVA 10**	•	•	•	•	•
LVA 20**		•	•	•	•
LVA 30**				•	•

Electrical oil level indicators **LEG** series

Technical data

LEG series electrical oil level indicators are supplied with a 3-hole fixing flange and a reed switch having NC-NO contacts.

Designed typically for installation on the vertical walls of oil tanks, these instruments can also be mounted to inspection doors of the OB475 series as indicators of minimum and maximum oil levels in the tank.

Warning

To operate correctly, the float must be positioned vertically and at a minimum distance of 35 mm from walls made of ferrous metal.

To change the contact from NC to NO, simply turn the float upside down.

The electrical properties indicated are referred to resistive loads; for capacitive and inductive loads and incandescent lamps, use protection circuits.

Electrical symbol:

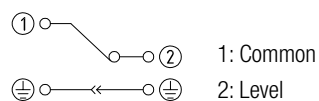

Note: to invert the contact status from NC to NO and vice versa, simply invert the float.

Installation

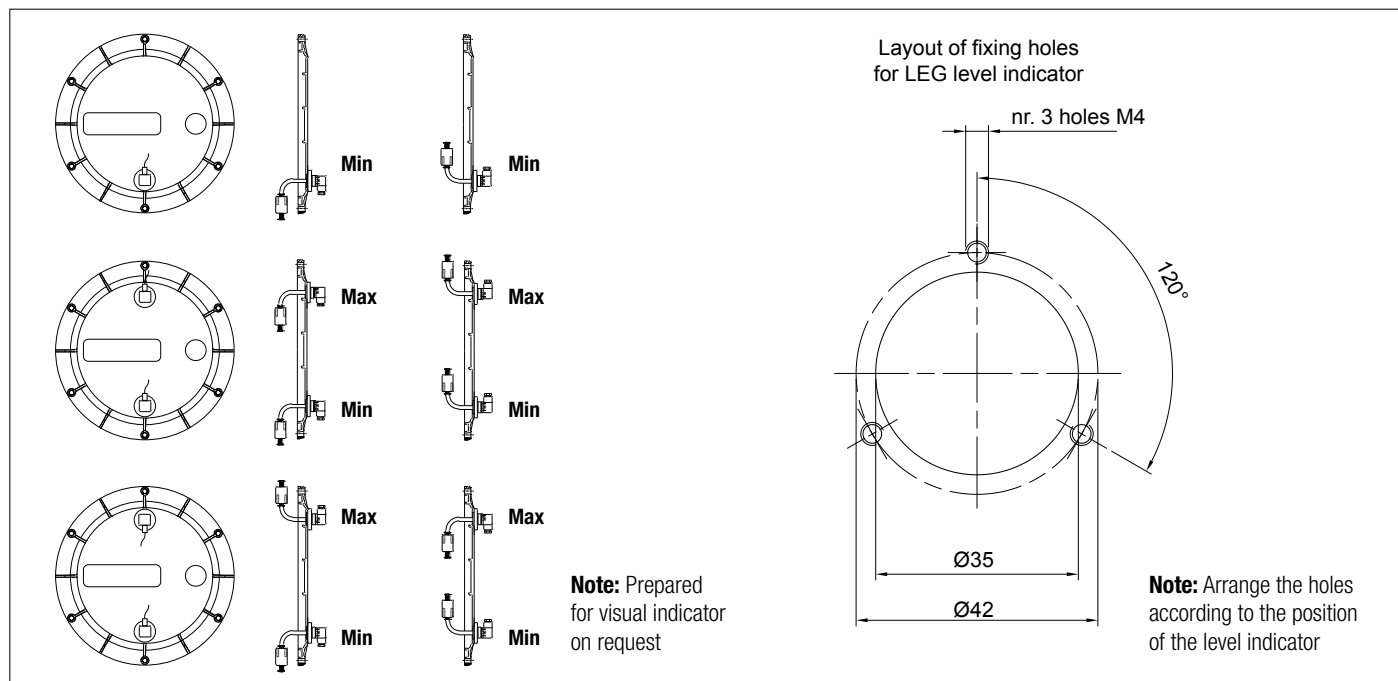

Dimensions

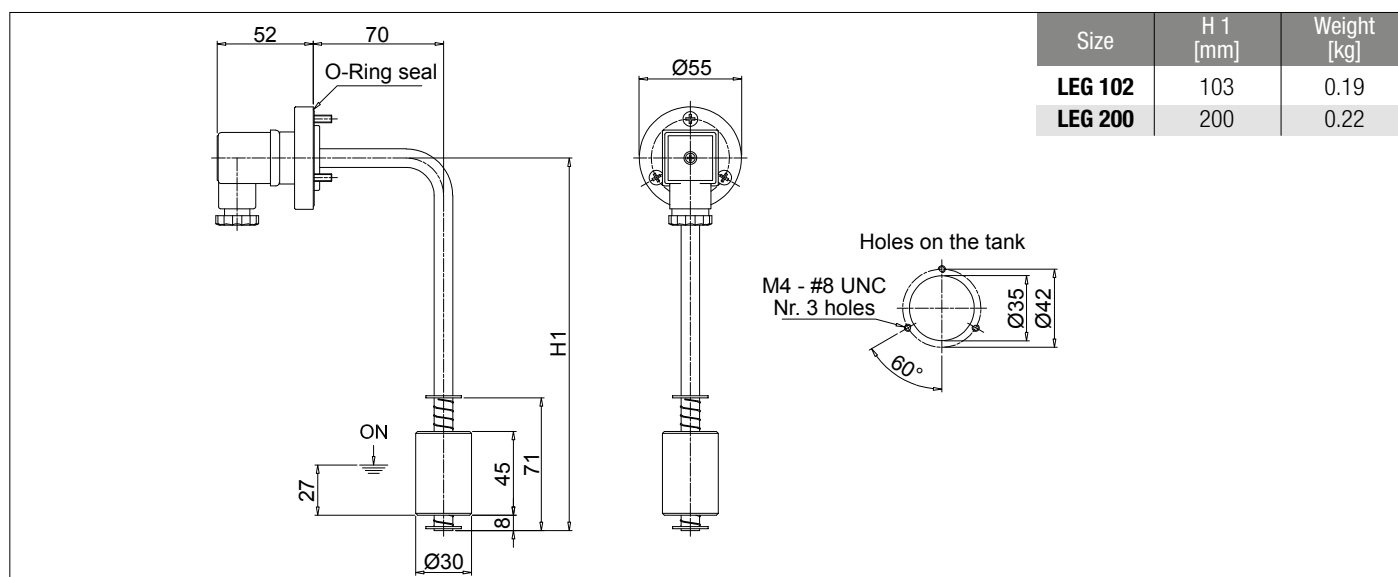

Visual level indicators code **LCPG42N...S**

Installation

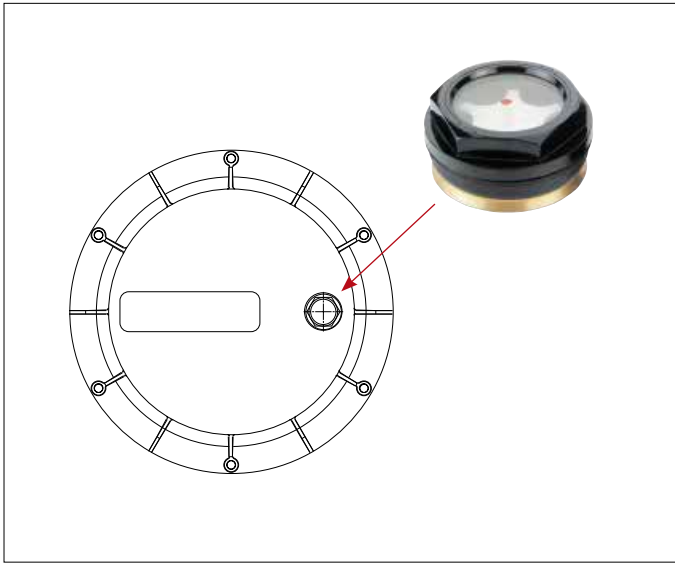

Dimensions

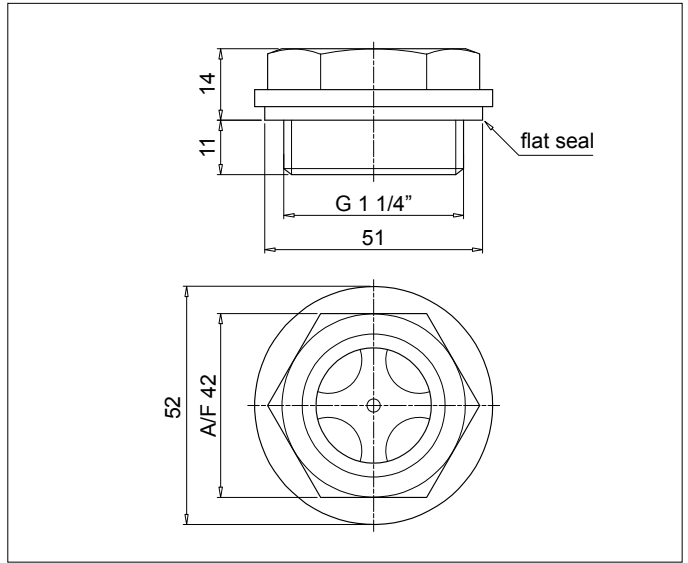

Available customization

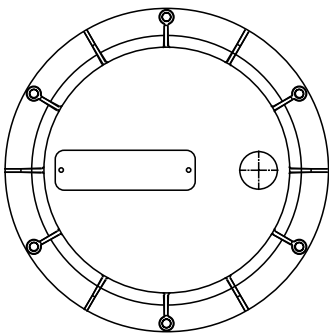

Nameplate with customer logo
Ordering information: **OB475LOGOP05**

The nameplates applied to the new inspection door are identical to those applied to the old door. The difference with the new door is that nameplates are fixed with rivets.

For ordering information codes, minimum order quantities, fixing hole positions and other details not indicated in this publication, contact MP Filtri Technical and Sales Department.

Technical data

Made of pressure die-cast aluminium alloy, these tanks feature superior strength and optimum design and are ideal for compact hydraulic power units.

Generously proportioned fins ensure efficient cooling.

The tank is supplied with:

- M6 threaded fixing holes for lid
- feet with M8 threaded fixing holes
- G 3/8" threaded drain hole

The lid is sealed by a gasket made of special paper, which must be ordered separately indicating code "GUS 10.0".

Dimensions

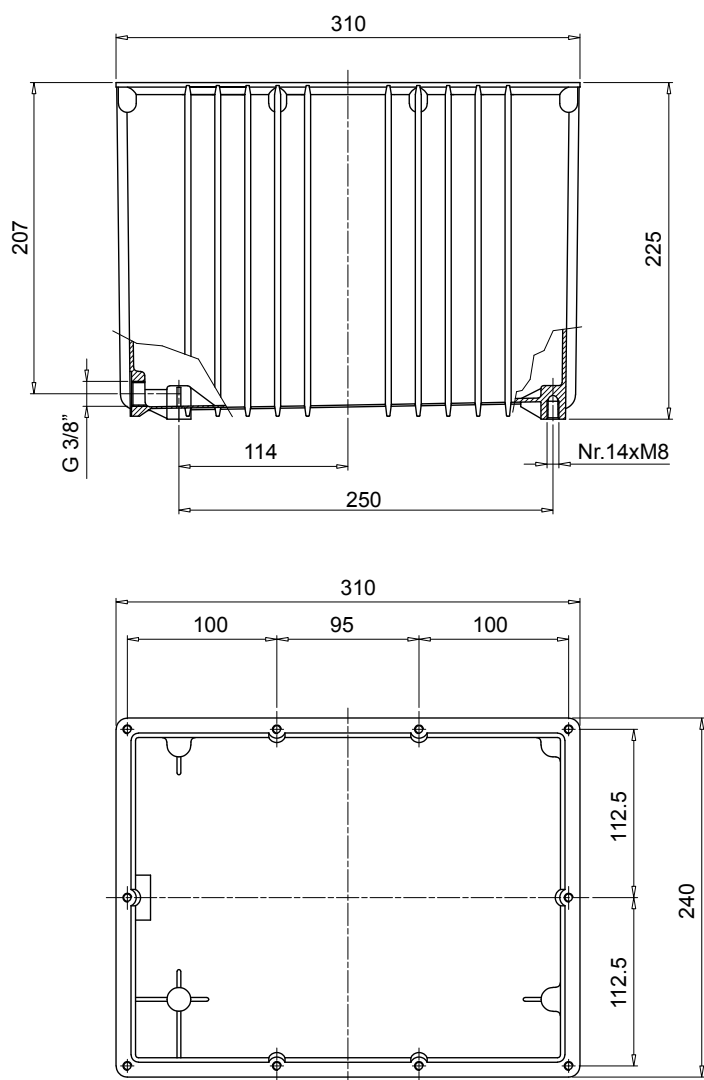

Code	Weight [kg]
SE10LT	4.0



Алматы (727)345-47-04
Ангарск (3955)60-70-56
Архангельск (8182)63-90-72
Астрахань (8512)99-46-04
Барнаул (3852)73-04-60
Белгород (4722)40-23-64
Благовещенск (4162)22-76-07
Брянск (4832)59-03-52
Владивосток (423)249-28-31
Владикавказ (8672)28-90-48
Владимир (4922)49-43-18
Волгоград (844)278-03-48
Вологда (8172)26-41-59
Воронеж (473)204-51-73
Екатеринбург (343)384-55-89

Россия +7(495)268-04-70

Иваново (4932)77-34-06
Ижевск (3412)26-03-58
Иркутск (395)279-98-46
Казань (843)206-01-48
Калининград (4012)72-03-81
Калуга (4842)92-23-67
Кемерово (3842)65-04-62
Киров (8332)68-02-04
Коломна (4966)23-41-49
Кострома (4942)77-07-48
Краснодар (861)203-40-90
Красноярск (391)204-63-61
Курск (4712)77-13-04
Курган (3522)50-90-47
Липецк (4742)52-20-81

Казахстан +7(727)345-47-04

Магнитогорск (3519)55-03-13
Москва (495)268-04-70
Мурманск (8152)59-64-93
Набережные Челны (8552)20-53-41
Нижний Новгород (831)429-08-12
Новокузнецк (3843)20-46-81
Ноябрьск (3496)41-32-12
Новосибирск (383)227-86-73
Омск (3812)21-46-40
Орел (4862)44-53-42
Оренбург (3532)37-68-04
Пенза (8412)22-31-16
Петрозаводск (8142)55-98-37
Псков (8112)59-10-37
Пермь (342)205-81-47

Беларусь +(375)257-127-884

Ростов-на-Дону (863)308-18-15
Рязань (4912)46-61-64
Самара (846)206-03-16
Санкт-Петербург (812)309-46-40
Саранск (8342)22-96-24
Саратов (845)249-38-78
Севастополь (8692)22-31-93
Симферополь (3652)67-13-56
Смоленск (4812)29-41-54
Сочи (862)225-72-31
Ставрополь (8652)20-65-13
Сургут (3462)77-98-35
Сыктывкар (8212)25-95-17
Тамбов (4752)50-40-97
Тверь (4822)63-31-35

Узбекистан +998(71)205-18-59

Тольятти (8482)63-91-07
Томск (3822)98-41-53
Тула (4872)33-79-87
Тюмень (3452)66-21-18
Улан-Удэ (3012)59-97-51
Ульяновск (8422)24-23-59
Уфа (347)229-48-12
Хабаровск (4212)92-98-04
Чебоксары (8352)28-53-07
Челябинск (351)202-03-61
Череповец (8202)49-02-64
Чита (3022)38-34-83
Якутск (4112)23-90-97
Ярославль (4852)69-52-93

Киргизия +996(312)96-26-47